

# A series



**Worm gear reducers and gearmotors**







# Contents

<b>1</b>	Rossi for You	4
<b>2</b>	Features, benefits and range	8
<b>3</b>	Product Overview	22
<b>4</b>	Installation and maintenance	100
<b>5</b>	Accessories and non-standard designs	108
<b>6</b>	Technical formulae	118

# 1

# Rossi for You



## Innovation

Rossi offers a wide range of **solutions for an evolving industry**, flexible and innovative gearboxes and gearmotors for customer tailored solutions to maximize performance and minimize the total cost of ownership.



## High quality, 3 years warranty

Our drive is to innovate and boost operations by manufacturing performing, precise, reliable and high-quality products all over the world. We are always one step forward in offering and developing solutions that can satisfy an unlimited number of application needs, even in the most demanding conditions.



## Reliability

We are a reliable company with the right flexibility and know-how to respond to worldwide market requests, in all application fields, without leaving aside our commitment for the environment and value on human safety, to protect everyone's future.



## Tools and processes

We continue to invest in new tools and processes, so our highly skilled specialist team in different fields are supporting you to find the best solution suitable for your demands, always by your side on every step of the project.



## After-sale service

Highly trained mechanics and support teams can ensure a fast and efficient after-sale service providing support worldwide.



## Digital support

Alongside our 24/7 **Rossi for You** support portal you have a suite of digital support tools enabling real time access to your order tracking, invoices, spare part tables download and contact to our service.

**70**  
YEARS

## Experience

Shaped by more than 60 years of history Rossi meets your unique needs whether you need a standard design or a customized solution.



# Global presence local service



## Local support

Sales, customer service,  
technical support, spare parts



## 15 branches\*



## Worldwide distribution network\*

A widespread sales network of subsidiaries and dealers in nearly all industrialized countries. By your side from the design to after-sale phase, Rossi is a flexible and dependable partner throughout the world.

**Rossi for You**, our customer web portal, provides a 24/7 global coordination of the ordering, supply and service processes.



## United States

Suwanee, GA




## Brazil


Cordeiropolis, SP




\*All contacts available on [www.rossi.com](http://www.rossi.com)



 Headquarters

 Branches

 Assembly plants

**United Kingdom**

Coventry



**Netherlands**

Panningen



**Germany**

Dreieich



**Poland**

Wroclaw



**Turkey**

Izmir



**China**

Shanghai



Suzhou



**Taiwan**

Kaohsiung City



**Spain**

Barcelona



**France**

Saint Priest



**Italy**

Modena



Ganaceto



Lecce



**India**

Coimbatore



**Australia**

Perth



**South Africa**

La Mercy

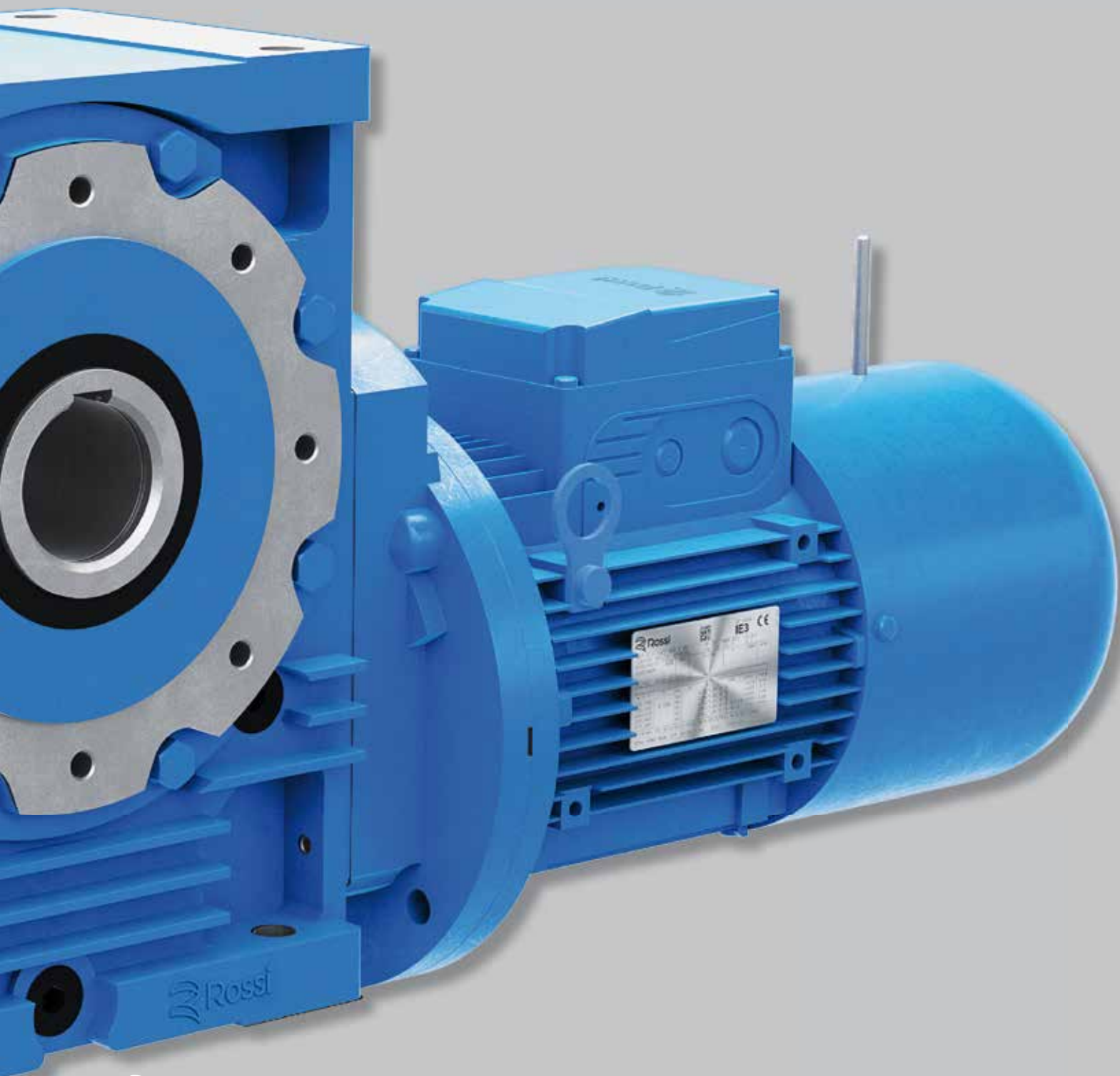


**Malaysia**

Kuala Lumpur



# Features, benefits and range





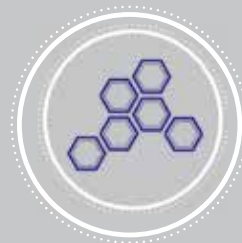
## Maximum performance

Suitable for wide variety of applications



## Gear accuracy rating

High performance thanks to maximum gear accuracy rating



## Modularity

Modular product for customized solutions



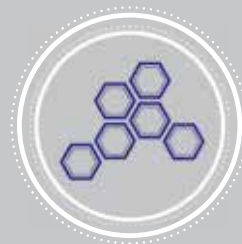
## Reliability

Minimum maintenance, high efficiency and noiselessness



## Digitalization

**Rossi for You**, the digital platform always available



## Know-how

Our experience at your service

## Worm gear reducers

32 ... 81



**RV**  
with worm gear pair



**R IV**  
with 1 cylindrical gear pair plus worm

100 ... 250



## Worm gearmotors

32 ... 81

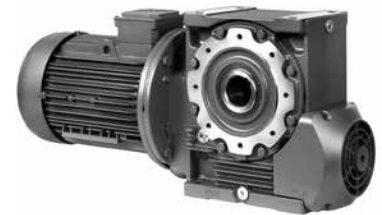


**MR V**  
with worm gear pair



**MR IV**  
with 1 cylindrical gear pair plus worm

100 ... 250



40 ... 81



**MR 2IV**  
with 2 cylindrical gear pairs plus worm

100 ... 126



## Combined gear reducer and gearmotors units



**RV + RV**



**RV + R IV**



**MR V + R 2I, 3I**



**MR IV + R 2I, 3I**



**RV + MR V**



**RV + MR IV**



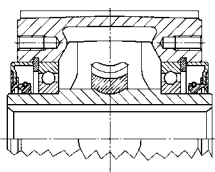
**MR V + MR 2I, 3I**



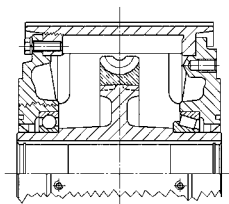
**MR IV + MR 2I, 3I**

## Gear reducers and gearmotors (worm wheel)

**32 ... 50**

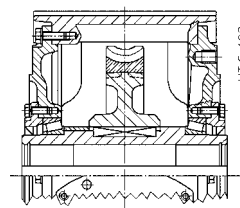


**63 ... 160**



**161**

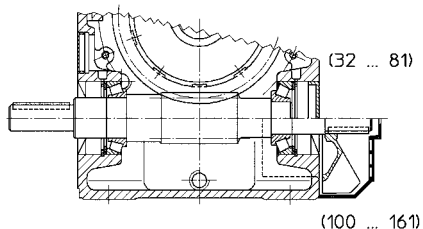
**200, 250**



U.T.C. 062

### Gear reducers (worm)

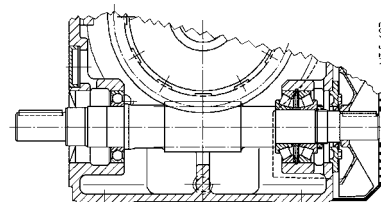
**32\* ... 161**



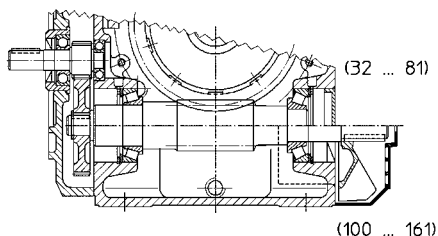
(32 ... 81)

(100 ... 161)

**200, 250**

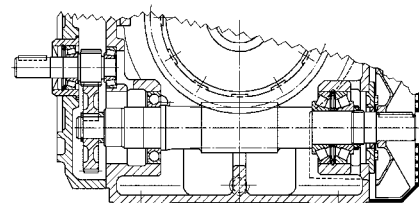


U.T.C. 063



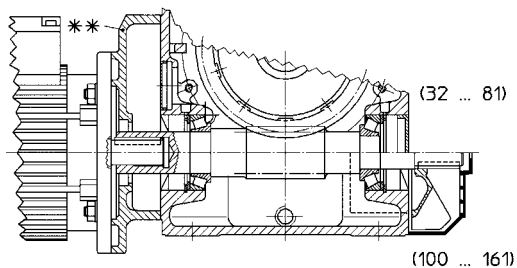
(32 ... 81)

(100 ... 161)



### Gearmotors (worm)

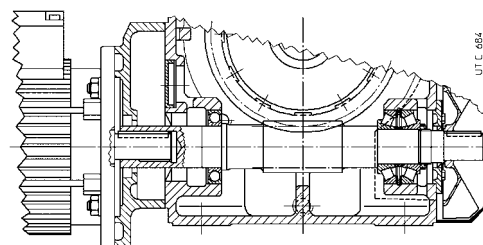
**32\* ... 161**



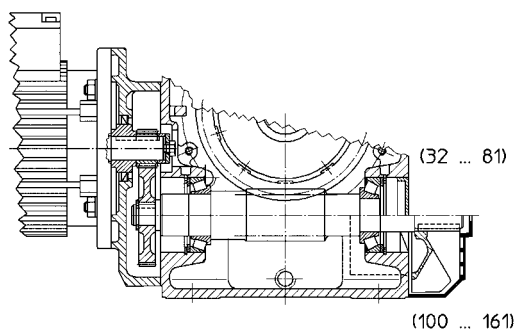
(32 ... 81)

(100 ... 161)

**200, 250**

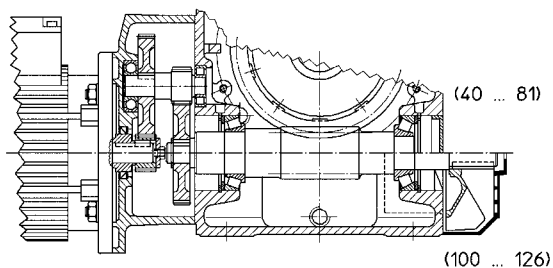
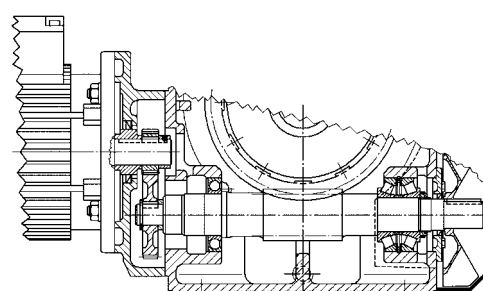


U.T.C. 064



(32 ... 81)

(100 ... 161)



(40 ... 81)

(100 ... 126)

\*\* Size : double row angular contact ball bearing plus ball bearing.

\*\* For: MR V 32, 40 with motor size **63** (11x140) and **71** (14x160) (see ch. 2b),

MR V 50 with motor size **71** (14x160) and **80** (19x200) (see ch. 2b),

MR V 63 ... 81 with motor size **80** (19x200) and **90** (24x200) (see c. 2b), motor flange is usually integral with housing.

**Universal mounting** having **feet integral with housing** on 3 faces (sizes 32 .. 81) or on 2 faces (sizes 100 ... 250) and **B14 flange** on 2 faces. Design and strength of the casing permit **interesting shaft mounting solutions**

**Thickened size and performance gradation** (some sequential sizes are obtained with the same housing and many components in common)

**High, reliable and tested performances (Ni bronze); optimization of worm gear pair performances (ZI involute profile and adequately conjugate worm wheel profile)**

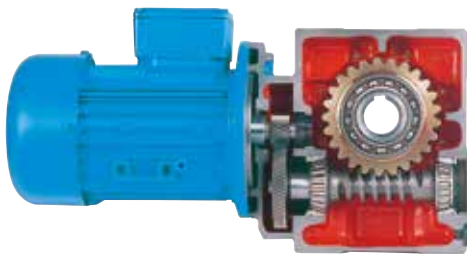
**Compactness, standardized dimensions and compliance with standards**

**Motor standardized to IEC**

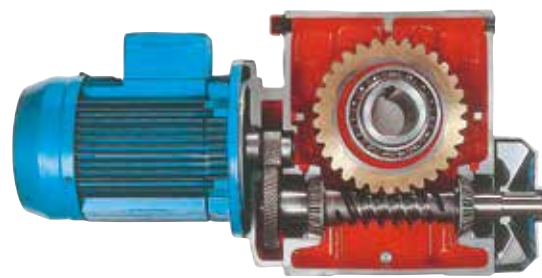
**Rigid and precise cast iron single-piece housing**

**Generous internal space between train of gears and housing allowing:**

- high oil capacity;
- lower oil contamination;
- greater duration of worm wheel and worm bearings;
- lower running temperature.



32 ... 81



100 ... 250

**Possibility of fitting particularly powerful motors and transmitting high nominal and maximum torques**

**Improved and up-graded modular construction both for component parts and assembled product which ensures manufacturing and product management flexibility**

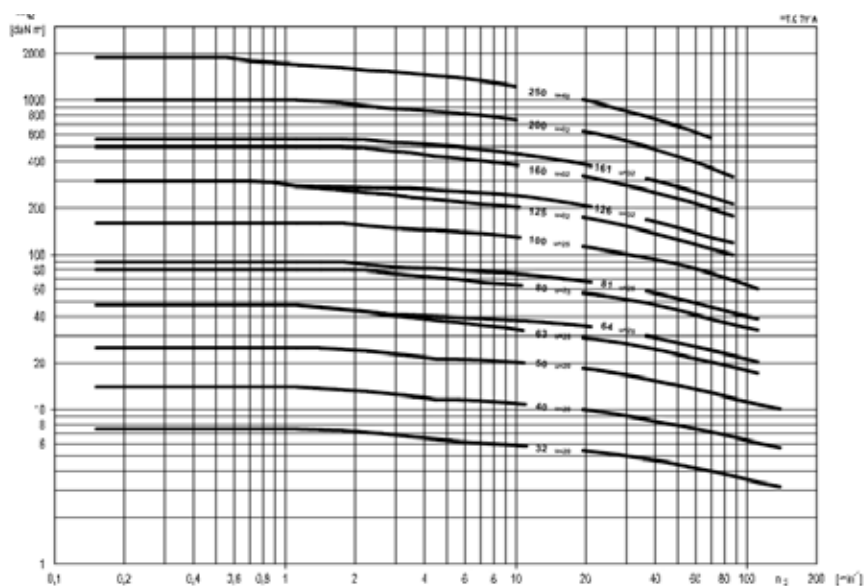
**High manufacturing quality standard**

**Possibility of obtaining multiple drives and at synchronous speed**

**Wide design and accessory availability:** shaft-mounting arrangements, mixed keying systems with key and locking elements (rings for sizes 32 ... 50, bush for sizes 63 ... 250), **reduced backlash**, etc.

## Reduced maintenance

A combination of modern concepts, analytical calculations carried out on **each single part**, use of the very latest machine tools, plus systematic checks on materials, assembling and workmanship, gives this series of gear reducers **high efficiency**, running **precision**, **regular motion** and **noiselessness**, **constant performance**, **life and reliability**, strength and overload withstanding and suitability for **heaviest applications**, wide size and ratio range, excellent service - **the advantages typically associated with high quality worm gear reducers produced in large series.**

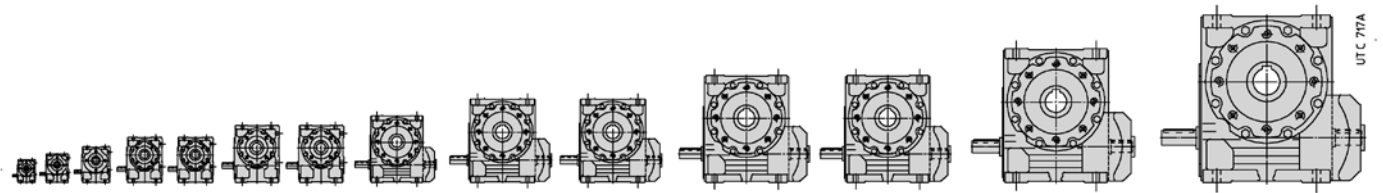


## a - Gear reducer

### Structural features

Main specifications are:

- **universal mounting** having **feet integral with housing** (lower, upper feet and vertical on the face opposite to motor for sizes 32 ... 81; lower and upper feet for sizes 100 ... 250) and **B14 flange** (integral with housing for sizes 32 ... 50) on 2 faces of hollow low speed shaft output. **B5 flange** with spigot «recess» which can be mounted onto B14 flanges (see chap. 5). Design and strength of the housing permit **interesting shaft mounting solutions**;



32	40	50	63	64	80	81	100	125	126	160	161	200	250	
71	82	100	125		150		180		225		280	335	410	1)
48	56	67	80		100		125		150		180	225	280	H <sub>0</sub>
19	24	28	32		38	40	48		60	70	75	90	110	D
4	7,1	12,8	21,9	26,1	42,2	50	83	133	158	245	291	462	802	M <sub>N2</sub> *
7,5	14	25	47,5		80	90	160		300	500	560	1000	1900	M <sub>2</sub> <sup>Grand.</sup>
180	250	355	530		800		1250		1800 (2000)	2650	3000	4500	6300 (7100)	F <sub>r2</sub>

\* concerning  $n_1 = 1400 \text{ min}^{-1}$  and transmission ratio stated in the scheme.

1) H, H<sub>0</sub> shaft height; D Ø low speed shaft end [mm]; M<sub>N2</sub>, M<sub>2</sub> <sup>Grand.</sup> torque [daN m]; F<sub>r2</sub> radial load [daN].

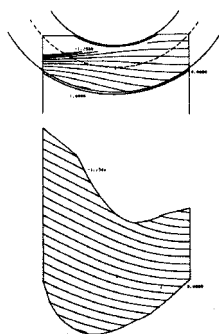
- thickened size (10 sizes with 4 size pairs with final centre distance 32 ... 250) and performance gradation; the size pairs are obtained with the same housing and with many components in common;
- gear reducer structure sized so as to accept particularly powerful motors – both MR V and MR IV – and to permit the transmission of high nominal and maximum torques at low output speeds, this being the particular advantage of worm gear pairs;
- gearmotor sizes 40 ... 126 with **2** cylindrical coaxial gear pair **first stage** in order to obtain high – **reversible** and irreversible – transmission ratios with standardized motor (63 ... 112) in a compact and economy way;
- normally, gearmotors MR V sizes 32, 40 (with motor sizes 63 and 71) 50 (with motor sizes 71 and 80) and 63 ... 81 (with motor sizes 80 and 90) have motor flange **integral** with the housing;
- hollow low speed shaft with keyway, and (sizes 63 ... 250) with circlip groove for removal purposes: in spheroidal cast iron (grey cast iron for sizes 32 and 40) integral with wormwheel (sizes 32 ... 161) or steel (sizes 200 and 250); standard (left or right extension) or double extension low speed shaft (see ch. 5).
- gear reducers: input face with machined surface (R V) or flange (R IV) and with fixing holes: wormshaft end with key, and reduced wormshaft end with circlip groove (the same as for R IV, MR IV, MR 2IV, MR V 160 ... 250 with coupling);
- gearmotors: **motor standardized to IEC directly** keyed into the worm (MR V), for motor sizes 200 ... 250 **patented** keying system to obtain easier installing and removing and avoid fretting corrosion; standardized motor with pinion directly mounted onto the shaft end (MR IV, MR 2IV);
- **fan cooling** (sizes 100 ... 250); use of **double extension worm-shaft** simply obtained by removing the fan cowl centre disc; for MR V 81 with motor 100 and 112, fan incorporated in motor mounting flange;
- bearings on worm: double row angular contact ball bearing plus ball bearing (size 32); face-to-face taper roller bearings (sizes 40 ... 161); paired back-to-back taper roller bearings plus one ball bearing (sizes 200 and 250);
- bearings on wormwheel: ball bearings (sizes 32 ... 160); taper roller bearings (sizes 161 ... 250);
- 200 UNI ISO 185 **cast iron single-piece housing** with transverse stiffening ribs, and high oil capacity;
- oil bath lubrication with **synthetic oil** (ch. 4) for «**long-life**» lubrication: units provided with one plug (sizes 32 ... 64) or two plugs (sizes 80 and 81) supplied **filled with oil**; with filler plug with **valve**, drain plug and level plug (sizes 100 ... 250) supplied **without oil**; sealed;
- **paint: external** coating in epoxy powder paint (sizes 32 ... 81) or water based dual compound acrylic-polyurethane resin basis enamel (sizes 100 ... 250) resistant to atmospheric and aggressive agents (corrosivity category C3 ISO 12944-2); suitable for further coats only with dual-compound products after degreasing and sanding; color blue RAL 5010 DIN 1843, other colors and/or painting cycles on request); **internal** protection with epoxy powder paint (sizes 32 ... 81) suitable to resist to synthetic oils or with synthetic paint (sizes 100 ... 250) suitable to resist synthetic oils.
- possibility of obtaining combined gear reducer and gearmotor units providing high transmission ratios with different train of gears depending on overall dimension, efficiency, and final output speed requirements.

## Train of gears:

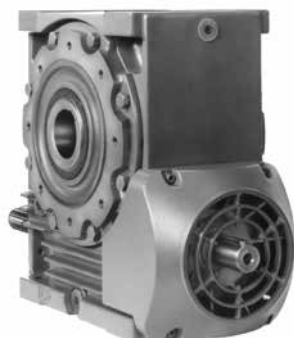
- worm gear pair; 1 cylindrical gear pair plus worm; with 2 cylindrical gear pairs plus worm gear pair (garmotor only);
- worm gear pairs, with **whole-number** transmission ratios ( $i = 10 \dots 63$ ) **identical** for the different sizes;  $i = 7$  for MR V 32 ... 81;
- 10 sizes having 4 sizes pairs (standard and strengthened) with final reduction center distance to R 10 series (32 ... 250) for a total of **14 sizes**;
- nominal transmission ratios to R 10 series (10 ... 315; up to 16 000 for combined units);
- casehardened and hardened cylindrical worm in 16CrNi4 or 20 MnCr5 UNI 7846-78 steel (depending on size) with ground and **superfinished involute** profile (**ZI**);
- wormwheel with profile especially conjugate to the worm through hob optimization, with hub in spheroidal or grey cast iron (depending on size) and **Ni bronze** CuSn12Ni2-B (EN1982-98) gear rim with high pureness and controlled phosphor contents;
- casehardened and hardened cylindrical gear pair in 16CrNi4 UNI 7846-78 steel with ground profile and helical toothing;
- train of gear load capacity calculated for breakage and wear; thermal capacity verified.

## Specific standards:

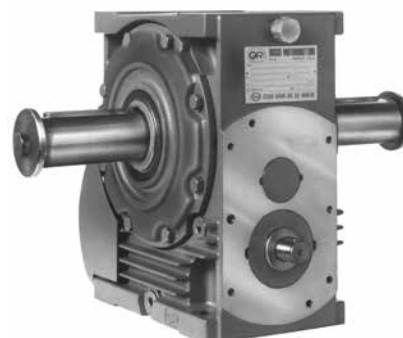
- nominal transmission ratios and principal dimensions according to UNI 2016 standard numbers (DIN 323-74, NF X 01.001, BS 2045-65, ISO 3-73);
- basic rack to BS 721-83; involute profile (ZI) to UNI 4760/4-77 (DIN 3975-76), ISO/R 1122/2-69);
- shaft heights to UNI 2946-68 (DIN 747-67, NF E 01.051, BS 5186-75, ISO 496-73);
- fixing flanges B14 and B5 (the latter with spigot «recess») taken from UNIL 13501-69 (DIN 42948-65, IEC 72.2);
- medium series fixing holes to UNI 1728-83 (DIN 69-71, NF E 27.040, BS 4186-67, ISO/R 273);
- cylindrical shaft ends (long or short) to UNI ISO 775-88 (DIN 748, NF E 22.051, BS 4506-70, ISO/R775/88) with tapped butt-end hole to UNI 9321 (DIN 332 Bl. 2-70, NF E 22.056) excluding d-D diameter ratio;
- parallel keys to UNI 6604-69 (DIN 6885 Bl. 1-68, NF E 27.656 and 22.175, BS 4235.1-72, ISO/R 773-69) except for specific cases of motor-to-gear reducer coupling where key height is reduced;
- mounting positions taken from UNEL 05513-67 (DIN 42950-64, IEC 34;7);
- worm gear pair load capacity and efficiency to **BS 721-83** integrated with ISO/CD 14521.



**Lines of contact and area of action** determined by computer to check on each individual gear pair design.



Fan cowl centre disc removed so as to utilize double extension wormshaft.



**Gear reducer design UO2B:** reduced wormshaft end (also suitable for R IV, MR IV, MR 2IV, MR V 160 ... 250 with coupling). Double extension low speed shaft.



## b - Electric motor

Gearmotor dimensions and masses of present catalog (see ch. 3.8 and 3.10) refer to HB and HBZ motors (cat. TX).

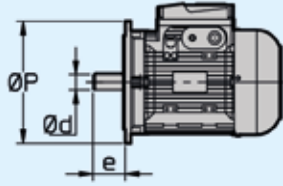
- motor **standardized to IEC**;
- asynchronous three-phase, totally-enclosed, externally ventilated, with cage rotor;
- single polarity, frequency 50 Hz, voltage  $\Delta$  230 V Y 400 V (size  $\leq$  132),  $\Delta$  400 V (size  $\geq$  160);
- IP 55 protection, insulation class F, temperature rise class B;
- rated power delivered on continuous duty S1 (excluding some cases of motor sizes with power not according to standard; see specific documentation) and referred to nominal voltage and frequency; maximum ambient temperature 40 °C and altitude 1 000 m;
- capacity to withstand one or more overloads up to 1,6 times the nominal load for a maximum total period of 2 min per single hour;
- starting torque with direct on-line start at least 1,6 times the nominal one (it is usually higher);
- mounting position B5 and derivatives as shown in the following table;
- **suitable for inverter duty** (generous electromagnetic sizing, low-loss electrical stamping, phase separators, etc.)
- designs available for every application need: flywheel, independent cooling fan, independent cooling fan and encoder, etc.

### Constructive features of HBZ brake motor

- particularly strong construction to withstand braking stresses; **maximum reduction of noise level**;
- spring-loaded d.c. electromagnetic brake; feeding from the terminal box; brake can also be independently fed directly from the line;
- braking torque **proportioned** to motor torque (usually  $M_f \approx 2 M_N$ ) and adjustable by adding or removing spring pairs;
- possibility of high frequency of starting;
- quick and rapid stop;
- hand lever for manual release with automatic return (on request for size  $\leq$  160S); removable lever rod.

For other specifications and details see **specific documentation of cat. TX**

### Main coupling dimensions

Motor size	 IEC 60072 (UNEL 13117-17, DIN 43677 Bl. 1.A-65) Motor mounting position								
	IM B5			B5R			B5A		
	Ød	e	- ØP	Ød	e	- ØP	Ød	e	- ØP
<b>63</b>	11	23	- 140	-	-	-	-	-	-
<b>71</b>	14	30	- 160	11	23	- 140	14	30	- 140
<b>80</b>	19	40	- 200	14	30	- 160	19	40	- 160
<b>90</b>	24	50	- 200	19	40	- 200	-	-	-
<b>100, 112</b>	28	60	- 250	24	50	- 200	-	-	-
<b>132</b>	38	80	- 300	28	60	- 250	-	-	-
<b>160</b>	42	110	- 350	38	80	- 300	-	-	-
<b>180</b>	48	110	- 350	-	-	-	-	-	-
<b>200</b>	55	110	- 400	48	110	- 350	-	-	-
<b>225</b>	60	140	- 450	-	-	-	-	-	-
<b>250</b>	65	140	- 550	60	140	- 450	-	-	-

## Short time duty (S2) and intermittent periodic duty (S3); duty cycles S4 ... S10

In case of a duty-requirement type S2 ... S10 the motor power can be increased as per the following table; starting torque keeps unchanged.

**Short time duty (S2).** — Running at constant load for a given period of time less than that necessary to reach normal running temperature, followed by a rest period long enough for motor's return to ambient temperature.

**Intermittent periodic duty (S3).** — Succession of identical work cycles consisting of a period of running at constant load and a rest period. Current peaks on starting are not to be of an order that will influence motor heat to any significant extent.

$$\text{Cyclic duration factor} = \frac{N}{N+R} \cdot 100\%$$

where:  $N$  being running time at constant load,  
 $R$  the rest period and  $N + R \leq 10$  min (if longer consult us).

Duty			Motor size <sup>1)</sup>		
			63 ... 90	100 ... 132	160 ... 280
S2	duration of running	90 min	1	1	1,06
		60 min	1	1,06	1,12
		30 min	1,12	1,18	1,25
		10 min	1,25	1,25	1,32
S3	cyclic duration factor	60%	1,12		
		40%	1,18		
		25%	1,25		
		15%	1,32		
S4 ... S10			consult us		

1) For motor sizes 90LC 4, 112MC 4, 132MC 4, consult us.

## Frequency 60 Hz

**Normal** motors up to size 132 wound for 50 Hz can be fed at 60 Hz; in this case speed increases by 20%. If input-voltage corresponds to winding voltage, power remains unchanged, providing that higher temperature rise values are acceptable, and that the power requirement is not unduly demanding, whilst starting and maximum torques decrease by 17%. If input-voltage is 20% higher than winding voltage, power increases by 20% whilst starting and maximum torques keep unchanged.

For **brake** motors see **specific literature**.

From size 160 upwards motors — both standard and brake ones — should be would for 60 Hz exploiting the 20% power increase as a matter of course.

## Power available with high ambient temperature or high altitude

When motor has to run at an ambient temperature higher than 40 °C or at altitude above sea level higher than 1 000 m, it has to be derated according to the following tables:

Ambient temperature [°C]	30	40	45	50	55	60	
$P/P_N$ [%]	106	100	96,5	93	90	86,5	
Altitude a.s.l. [m]	1 000	1 500	2 000	2 500	3 000	3 500	4 000
$P/P_N$ [%]	100	98	92	88	84	80	76

## Specific standards:

- nominal powers and dimensions to CENELEC HD 231 (IEC 72-1, DIN 42677, NF C51-120, BS 5000-10 and BS 4999-141) for mounting positions IM B5, IM B14 and derivatives;
- nominal performances and running specifications to CENELEC EN 60034-1 (IEC 34-1, CEI EN 60034-1, DIN VDE 0530-1, NF C51-111, BS EN 60034-1);
- protection to CENELEC EN 60034-5 (IEC 34-5, CEI 2-16, DIN EN 60034-5, NF C51-115, BS 4999-105);
- mounting positions to CENELEC EN 60034-7 (IEC 34-7, CEI EN 60034-7, DIN IEC 34-7, NF C51-117, BS EN 60034-7);
- balancing and vibration velocity (vibration under standard rating N) to CENELEC HD 53.14 S1 (IEC 34-14, ISO 2373 CEI 2-23, BS 4999-142); motors are balanced with half key inserted into shaft extension;
- cooling to CENELEC EN 60034-6 (CEI 2-7, IEC 34-6): standard type IC 411; type IC 416 for non-standard design with axial independent cooling fan.

## Asynchronous three-phase motors, brake motors



### HE - HB

Asynchronous three-phase motor



### HEZ - HBZ

Asynchronous three-phase **brake motor** with **d.c. brake**



### HBF

Asynchronous three-phase **brake motor** with **a.c. brake**



### HBV

Asynchronous three-phase **brake motor** with **d.c. safety brake**

Advanced design motors sharing the **same stator windings**, the same **rotors**, the same  **housings**, the same  **flanges**, the same performance, and the majority of technical solutions with its twin brake motor series (**HEZ, HBZ, HBF, and HBV**).

The generous electromagnetic sizing allow to achieve **high efficiency values** complying **with different energy saving regulations**:

– Efficiency class **IE3 (ErP)** for HB and HE;

– Efficiency class **IE3 (ErP)** for HEZ, on request for HBZ

The electric design (terminal block, name plate, etc.) has been studied to comply, as standard, also with **NEMA MG1-12** for the maximum application flexibility and facility.

The strength and the precision of mechanical construction, the generous bearings and the wide range of non-standard designs available on catalog make this motor particularly suitable for coupling with gearmotors.

Thanks to its outstanding **low noise, progressivity** and **dynamic** characteristics, it is specifically suitable for **coupling with gearmotor minimizing the dynamic overloads** deriving from **starting and braking phases** (especially in case of motion reversals) and maintaining a **very good braking torque value**.

The excellent **operation progressivity** - when starting and braking - is assured by the brake anchor which is less quick in the impact (compared to a.c. HBF) and by the slight quickness of d.c. brakes.

Offering a comprehensive **range of accessories and non-standard designs** in order to satisfy all possible gearmotor application fields.

The **high reactivity** typical of **a.c. brake** and the **high braking capacity** make this brake motor **particularly suitable for heavy duties** requiring **quick brakings** and a **high number of operations** (e.g.: lifts with high frequency of starting, usually for size > 132, and/or for jog operations).

Vice versa, its very **high dynamic characteristics** (rapidity and frequency of starting) **are not advisable for the use in gearmotor** coupling, especially when these features are not strictly necessary for the application (avoiding useless overloads on the whole transmission).

Comprehensive **range of accessories and non-standard designs** in order to satisfy all application needs of gearmotors (in particular for HBF: IP 56, IP 65, encoder, independent cooling fan, independent cooling fan and encoder, double extension shaft, etc.).

Featuring **maximum economy, very reduced overall dimensions and moderate braking torque**, it is suitable for the coupling with gearmotor and can be applied as brake for **safety or parking stops** (e.g. cutting machines) and for operations at deceleration ramp end **during the running with inverter**.

The standard cast iron fan supplies a flywheel effect increasing the very good progressivity of starting and braking (typical of d.c. brake) being particularly **suitable for «light»<sup>1)</sup> traverse movements**.

1) Mechanism group M4 (max 180 starts/h) and on-load running L1 (light) or L2 (moderate) to ISO 4301 /1, F.E.M. /II 1997.

# Symbols and units of measure

Symbols used in the catalogue and formulae, in alphabetical order, with relevant units of measure.

Symbol	Definition	Units of measure			Notes
		In catalog	In the formulae		
			Technical System	SI <sup>1)</sup> System	
	dimensions	mm	–		
<i>a</i>	acceleration	–	m/s <sup>2</sup>		
<i>d</i>	diameter	–	m		
<i>f</i>	frequency	Hz	Hz		
<i>f<sub>s</sub></i>	service factor				
<i>f<sub>t</sub></i>	thermal factor				
<i>F</i>	force	–	kgf	N <sup>2)</sup>	1 kgf ≈ 9,81 N ≈ 0,981 daN
<i>F<sub>r</sub></i>	radial load	daN	–		
<i>F<sub>a</sub></i>	axial loads	daN	–		
<i>g</i>	acceleration of gravity	–	m/s <sup>2</sup>		normal value 9,81 m/s <sup>2</sup>
<i>G</i>	weight (weight force)	–	kgf	N	
<i>Gd<sup>2</sup></i>	dynamic moment	–	kgf m <sup>2</sup>	–	
<i>i</i>	transmission ratio				$i = \frac{n_1}{n_2}$
<i>I</i>	electric current	–	A		
<i>J</i>	moment of inertia	kg m <sup>2</sup>	–	kg m <sup>2</sup>	
<i>L<sub>b</sub></i>	bearing life	h	–		
<i>m</i>	mass	kg	kgf s <sup>2</sup> /m	kg <sup>3)</sup>	
<i>M</i>	torque	daN m	kgf m	N m	1 kgf m ≈ 9,81 N m ≈ 0,981 daN m
<i>n</i>	speed	min <sup>-1</sup>	giri/min rev/min	–	1 min <sup>-1</sup> ≈ 0,105 rad/s
<i>P</i>	power	kW	CV	W	1 CV ≈ 736 W ≈ 0,736 kW
<i>P<sub>t</sub></i>	thermal power	kW	–		
<i>r</i>	radius	–	m		
<i>R</i>	variation ratio				$R = \frac{n_{2 \max}}{n_{2 \min}}$
<i>s</i>	distance	–	m		
<i>t</i>	Celsius temperature	°C	–		
<i>t</i>	time	s min h d	s		1 min = 60 s 1 h = 60 min = 3 600 s 1 d = 24 h = 86 400 s
<i>U</i>	voltage	V	V		
<i>v</i>	velocity	–	m/s		
<i>W</i>	work, energy	MJ	kgf m	J <sup>4)</sup>	
<i>z</i>	frequency of starting	starts/h	–		
<i>α</i>	angular acceleration	–	rad/s <sup>2</sup>		
<i>η</i>	efficiency				
<i>η<sub>s</sub></i>	static efficiency				
<i>μ</i>	friction coefficient				
<i>φ</i>	plane angle	°	rad		1 rev = 2 π rad $1^\circ = \frac{\pi}{180}$ rad
<i>ω</i>	angular velocity	–	–	rad/s	1 rad/s ≈ 9,55 min <sup>-1</sup>

Additional indexes and other signs

Ind.	Definition
max	maximum
min	minimum
N	nominal
1	relating to high speed shaft (input)
2	relating to low speed shaft (output)
+	from ... to
≈	approximately equal to
≥	greater than or equal to
≤	less than or equal to

1) SI are the initials of the International Unit System, defined and approved by the General Conference on Weights and Measures as the only system of units of measure.  
Ref. CNR UNI 10 003-84 (DIN 1 301-93 NF X 02.004, BS 5 555-93, ISO 1 000-92).

UNI: Ente Nazionale Italiano di Unificazione.

DIN: Deutscher Normenausschuss (DNA).

NF: Association Française de Normalisation (AFNOR).

BS: British Standards Institution (BSI).

ISO: International Organization for Standardization.

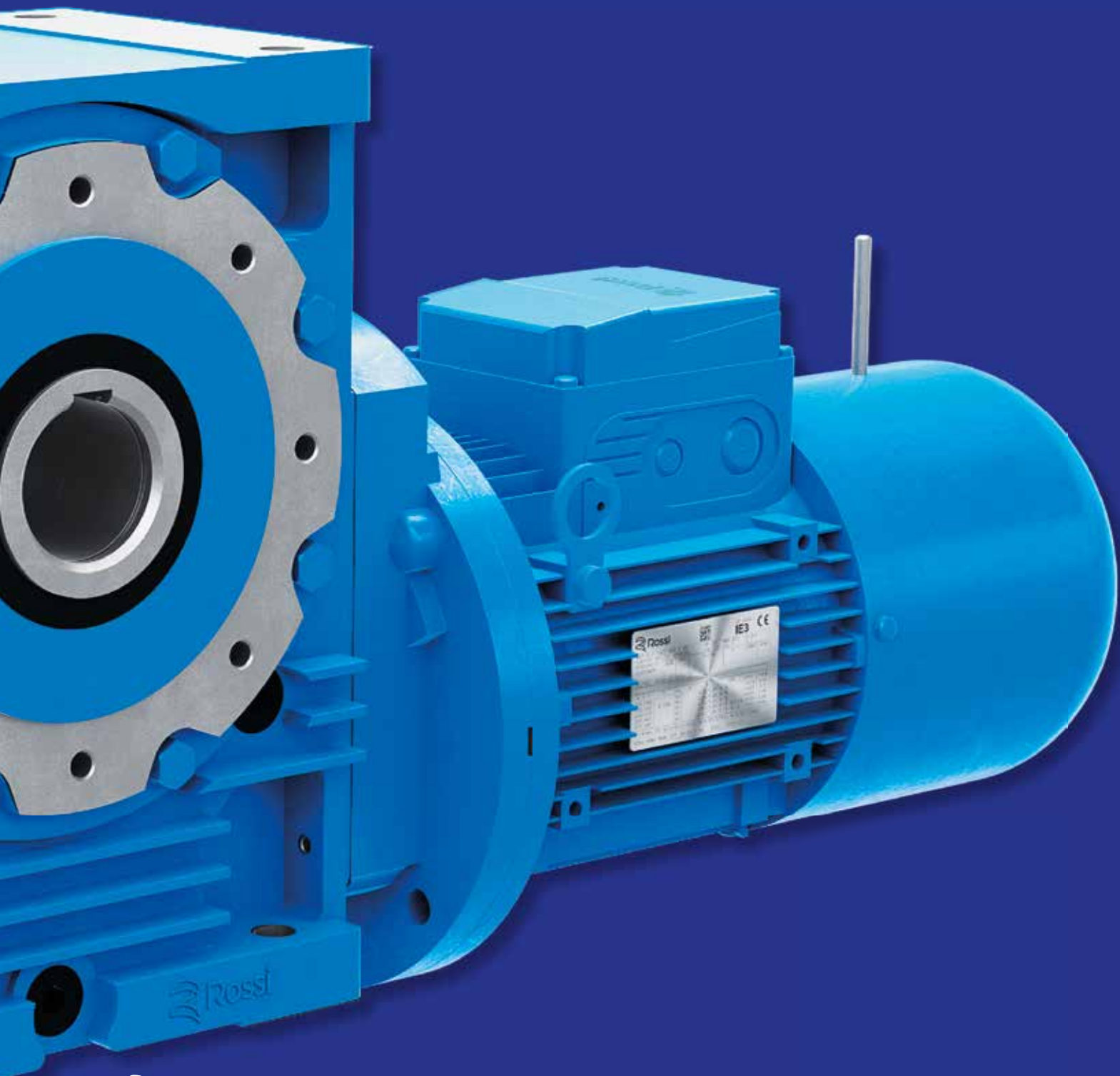
2) Newton [N] is the force imparting an acceleration of 1 m/s<sup>2</sup> to a mass of 1 kg.

3) Kilogramme [kg] is the mass of the prototype kept at Sèvres (i.e. 1 dm<sup>3</sup> of distilled water at 4 °C).

4) Joule [J] is the work done when the point of application of a force of 1 N is displaced through a distance of 1 m.

blank page

# Product overview





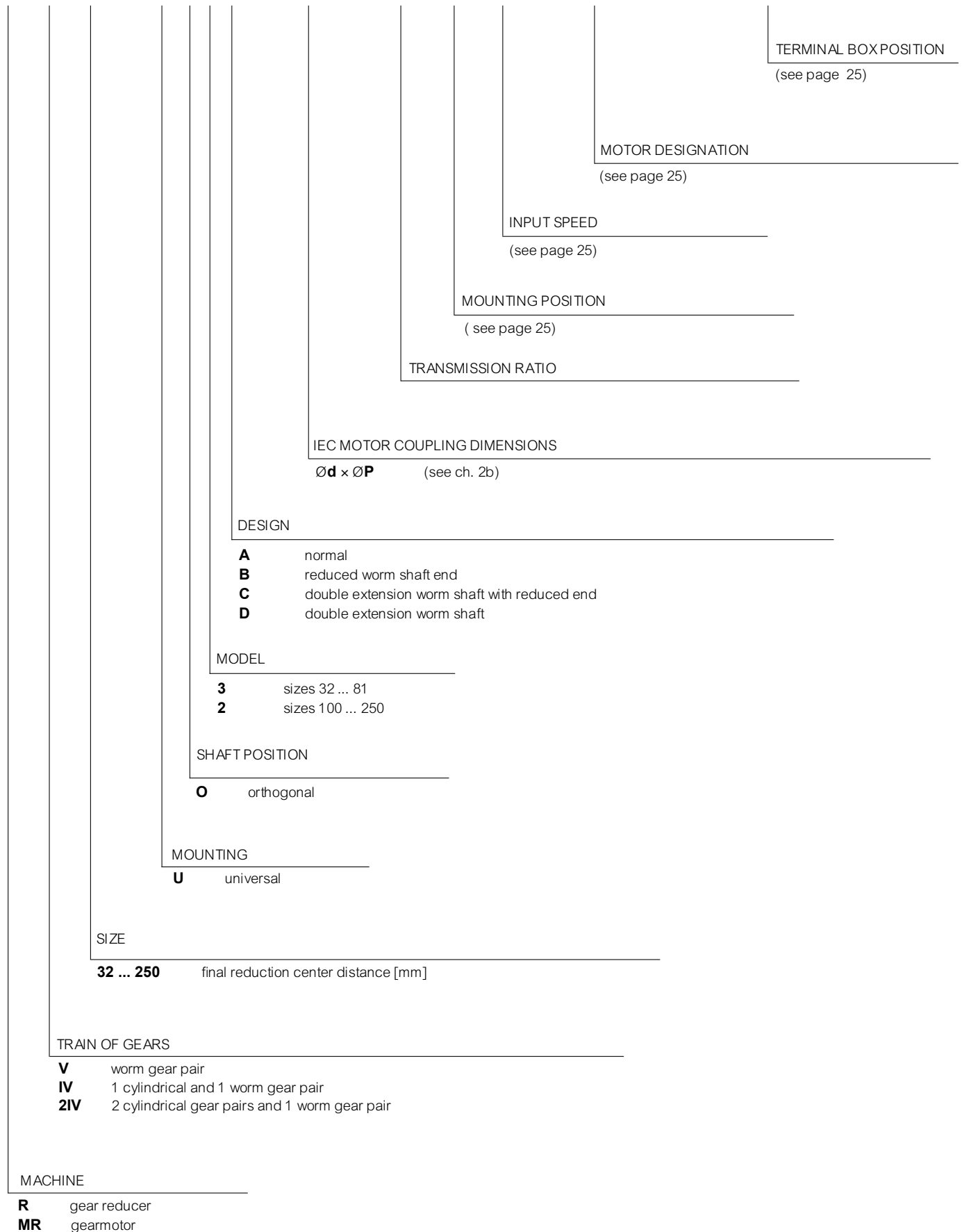


## Section content

3.1	Designation	24
3.2	Thermal power	26
3.3	Service factor	28
3.4	Selection	29
3.5	Nominal powers and torques	33
3.6	Designs, dimensions, mounting positions and oil quantities	40
3.7	Gearmotors selection tables	42
3.8	Designs, dimensions, mounting positions and oil quantities	60
3.9	Gear reducer and gearmotor combined units	65
3.10	Combined units dimensions	68
3.11	Radial loads on high speed shaft end	74
3.12	Radial and axial loads on low speed shaft end	74

## Designation code

**R V 250 U O 2 A - 50 B3**  
**MR V 80 U O 3 A - 24 × 200 - 25 V5 HB3 90L4 230.400-50 B5 TB3**



## Gear reducer mounting position

**Gear reducer and gearmotor mounting positions are described** in ch. 3.6, 3.8 (the mounting position designation refers to foot mounting only, even if gear reducers are for universal mounting; e.g.: B14 flange fastening and derivatives; B5 flange fastening and derivatives, see ch.5).

When having no particular needs, **prefer B3 mounting position** for its technical and economic cost effectiveness (maximum simplification of lubrication system, lower oil splash, lower gear reducer heating, stock availability).

## Input speed

Complete the designation stating the input speed  $n_1$ , in the following cases:

- $n_1 > 1400 \text{ min}^{-1}$ ;
- for gear reducer sizes 200 and 250 mounting position B7

Example:

R V 250 UO2A / 50  $n_1 = 560 \text{ min}^{-1}$ , **mounting position B7**

## Motor

When the gearmotor is supplied **equipped with a standard Rossi motor**, fill in the designation stating the motor designation (ref. cat. TX).

Example:

MR V 200 UO2A - 48 x 350 - 25

**HB3 180M 4 400-50 B5**

When **brake motor** is required, insert the letters **HBZ** (ref. cat. TX).

Example:

MR V 200 UO2A - 48 x 350 - 25

**HBZ 180M 4 400-50 B5**

When the gearmotor is equipped **without motor**, omit the designation and add «without motor».

Esempio:

MR V 200 UO2A - 48350 - 25

**without motor**

When motor is supplied by the **Buyer**<sup>1)</sup>, complete the designation by stating the description of «motor supplied by us».

1) The motor, supplied by the Buyer must be to IEC with mating surfaces machined under accuracy rating IEC 60072-1 and is to be sent carriage and expenses paid to our factory for fitting to the gear reducer.

Example:

MR V 200 UO2A - 48350 - 25

**motore supplied by us**

## Motor terminal box position

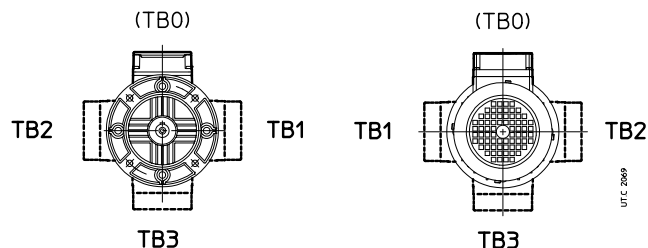
Complete the designation stating the motor terminal box position if differing from the standard one (TB0; see ch. 10 and scheme below); the cable input is Buyer's responsibility.

Example:

MR V 200 UO2A - 48350 / 25

HB3 180M 4 400-50 B5 **TB3**

View from drive end (D)



## Accessories and non-standard designs

In the event of a gear reducer or gearmotor being required in a design different from those stated above, specify it in detail (ch. 5).

Nominal thermal power  $P_{tN}$ , written in red in the tables in the following page, is that which can be applied at the gear reducer input without exceeding 95 °C<sup>1)</sup> approximately oil temperature when operating in following running conditions:

- input speed  $n_1 = 1\ 400\ \text{min}^{-1}$ ;
- mounting position B3;
- continuous duty S1;
- maximum ambient temperature 40 °C;
- maximum altitude 1 000 m above sea level;
- air speed  $\geq 1,25\ \text{m/s}$  (typical value in presence of a gearmotor with self cooled motor).

Wherever nominal thermal power  $P_{tN}$  is indicated in ch 3.5 and 3.7 it should be always verified that the applied power  $P_1$  is less than or equal to gear reducer nominal thermal power  $P_{tN}$  multiplied by the corrective coefficients  $f_2, f_3, f_4, f_5$  (stated in the following tables) considering the several operational conditions:

$$P_1 \leq P_{tN} \cdot f_2 \cdot f_3 \cdot f_4 \cdot f_5$$

When this condition is not satisfied consider the use of special lubricant or a cooling unit with heat exchanger: consult us.

Thermal power needs not be taken into account when maximum duration of continuous running time is 1 ÷ 3 h (from small to large gear reducer sizes) followed by rest periods long enough to restore the gear reducer to near ambient temperature (likewise 1 ÷ 3 h). In case of maximum ambient temperature above 50 °C or below 0 °C consult us.

Thermal factor  $f_2$  according to **ambient temperature** and **duty**

Maximum ambient temperature [°C]	Continuous duty S1	$f_2$			
		Intermittent duty S3 ... S6			
		Cyclic duration factor for 60 min running <sup>2)</sup>			
		60	40	25	15
50	0,8	0,95	1,06	1,18	1,32
40	<b>1</b>	1,18	1,32	1,5	1,7
30	1,18	1,4	1,6	1,8	2
20	1,32	1,6	1,8	2	2,24
10	1,5	1,8	2	2,24	2,5

Thermal factor  $f_3$  according to **mounting position**

Train of gears	$f_3$	
	Mounting position	
	B3, B8, V5, V6	B6, B7
V	1	0,9
IV, 2IV	1	1

Thermal factor  $f_4$  according to **altitude**

Altitude a.s.l [m]	$f_4$
$\leq 1\ 000$	<b>1</b>
1 000 ÷ 2 000	0,95
2 000 ÷ 3 000	0,9
3 000 ÷ 4 000	0,85
$\geq 4\ 000$	0,8

Thermal factor  $f_5$  according to **air speed** on the housing

Air speed m/s	Working environment	$f_5$
< 0,63	very small or no air movement or gear reducer shielded	consult us
0,63	small and with limited air movement	0,71
1	large and without ventilation	0,9
1,25	large and with slight ventilation (e.g. gearmotor with self-cooled motor)	<b>1</b>
2,5	outdoor ventilated	1,18
4	strong air movement	1,32

1) Corresponding to an average temperature of the external housing surface of approximately 85 °C; locally housing temperature can achieve the oil temperature.  
7) (Duration of running on load / 60) · 100 [%].

**P<sub>tN</sub> for gear reducers and gearmotors**

size **32**

n <sub>worm</sub> <sup>1)</sup> min <sup>-1</sup>	u <sub>worm</sub>									
	7	10	13	16	20	25	32	40	50	63
1 400	0,82	0,67	-	-	0,44	-	-	-	-	-
1 120	-	0,61	-	-	0,4	-	-	-	-	-
900	-	-	-	-	-	-	-	-	-	-
710	-	-	-	-	-	-	-	-	-	-
560	-	-	-	-	-	-	-	-	-	-
450	-	-	-	-	-	-	-	-	-	-

size **50**

n <sub>worm</sub> <sup>1)</sup> min <sup>-1</sup>	u <sub>worm</sub>									
	7	10	13	16	20	25	32	40	50	63
1 400	1,72	1,4	1,29	1,18	0,92	0,84	0,76	0,68	-	-
1 120	1,58	1,28	1,16	1,06	0,83	0,76	0,68	0,62	-	-
900	1,43	1,16	1,05	0,96	0,75	0,69	0,63	-	-	-
710	1,31	1,05	0,96	0,88	0,69	0,63	0,57	-	-	-
560	1,2	0,96	0,88	0,81	0,63	0,58	-	-	-	-
450	1,1	0,89	0,82	0,75	0,58	0,54	-	-	-	-
355	1,01	0,81	-	-	0,53	-	-	-	-	-
280	-	-	-	-	0,5	-	-	-	-	-

sizes **80, 81**

n <sub>worm</sub> <sup>1)</sup> min <sup>-1</sup>	u <sub>worm</sub>									
	7	10	13	16	20	25	32	40	50	63
1 400	4,15	3,59	3,04	2,82	2,58	2,1	1,83	1,66	1,49	1,32
1 120	3,82	3,28	2,76	2,54	2,34	1,82	1,65	1,5	1,35	-
900	3,51	2,99	2,51	2,31	2,11	1,65	1,49	1,36	1,23	-
710	3,17	2,7	2,27	2,09	1,91	1,49	1,35	1,23	1,11	-
560	2,89	2,46	2,06	1,89	1,75	1,36	1,22	1,13	-	-
450	2,67	2,28	1,9	1,75	1,61	1,24	1,13	1,05	-	-
355	2,47	2,09	1,73	1,6	1,49	1,14	1,04	-	-	-
280	2,31	1,94	1,61	1,49	-	1,06	0,96	-	-	-
224	2,11	1,8	1,5	-	-	0,99	-	-	-	-
180	1,98	1,69	1,4	-	-	-	-	-	-	-
140	1,8	-	-	-	-	-	-	-	-	-
112	-	-	-	-	-	-	-	-	-	-

sizes **125, 126**

n <sub>worm</sub> <sup>1)</sup> min <sup>-1</sup>	u <sub>worm</sub>									
	7	10	13	16	20	25	32	40	50	63
1 400	-	15,2	14	12,2	11,2	10,4	8	7,1	6,6	5,9
1 120	-	13,1	11,9	10,3	9,5	8,8	6,7	6	5,6	-
900	-	11,3	10,2	8,9	8,1	7,5	5,8	5,1	4,76	-
710	-	9,6	8,7	7,5	6,9	6,4	4,89	4,36	4,03	-
560	-	8,3	7,4	6,4	5,8	5,4	4,17	3,7	3,44	-
450	-	7,2	6,4	5,6	5,1	4,7	3,6	3,21	2,99	-
355	-	6,2	5,6	4,81	4,4	4,11	3,12	2,81	-	-
280	-	5,5	4,99	4,27	3,92	3,64	2,77	2,49	-	-
224	-	4,91	4,46	3,81	3,49	3,24	2,48	2,23	-	-
180	-	4,42	3,98	3,4	3,11	-	2,21	2,01	-	-
140	-	3,9	3,51	3,01	2,75	-	1,97	-	-	-
112	-	3,48	3,14	2,68	-	-	1,75	-	-	-
90 <sup>2)</sup>	-	3,14	2,85	-	-	-	-	-	-	-

size **200**

n <sub>worm</sub> <sup>1)</sup> min <sup>-1</sup>	u <sub>worm</sub>									
	7	10	13	16	20	25	32	40	50	63
1 400	-	-	33,1	31,3	27	25,1	19,4	17,7	16,2	14,5
1 120	-	-	28,6	26,9	23,2	21,5	16,7	15	13,9	12,3
900	-	-	24,7	23,1	20	18,3	14,5	12,8	11,7	10,5
710	-	-	21,2	19,9	17	15,7	12,2	10,9	10	8,9
560	-	-	18,2	17	14,5	13,4	10,4	9,3	8,5	7,6
450	-	-	15,8	14,7	12,6	11,6	9	8	7,3	6,5
355	-	-	13,7	12,7	10,8	10	7,7	6,9	6,3	5,7
280	-	-	12	11,2	9,5	8,8	6,8	6,1	5,6	-
224	-	-	10,7	10	8,5	7,8	6	5,4	5	-
180	-	-	9,6	9	7,6	7	5,4	4,85	4,52	-
140	-	-	8,4	7,8	6,6	6,1	4,74	4,25	3,93	-
112	-	-	7,5	7,1	5,9	5,5	4,17	3,83	-	-
90 <sup>2)</sup>	-	-	6,8	6,3	5,3	4,93	3,79	3,46	-	-

size **40**

n <sub>worm</sub> <sup>1)</sup> min <sup>-1</sup>	u <sub>worm</sub>									
	7	10	13	16	20	25	32	40	50	63
1 400	1,14	0,93	0,84	0,77	0,6	0,55	0,49	-	-	-
1 120	1,04	0,84	0,76	0,69	0,55	0,49	0,45	-	-	-
900	0,94	0,76	0,7	0,64	0,5	0,46	-	-	-	-
710	0,87	0,7	0,63	0,58	0,45	0,41	-	-	-	-
560	0,8	0,64	-	-	0,41	-	-	-	-	-
450	-	-	-	-	0,38	-	-	-	-	-

sizes **63, 64**

n <sub>worm</sub> <sup>1)</sup> min <sup>-1</sup>	u <sub>worm</sub>									
	7	10	13	16	20	25	32	40	50	63
1 400	2,73	2,34	1,97	1,81	1,67	1,3	1,17	1,08	0,96	-
1 120	2,49	2,13	1,79	1,64	1,5	1,17	1,06	0,97	-	-
900	2,28	1,93	1,62	1,48	1,37	1,06	0,95	0,88	-	-
710	2,07	1,75	1,46	1,34	1,24	0,96	0,87	-	-	-
560	1,9	1,61	1,34	1,23	-	0,88	0,8	-	-	-
450	1,76	1,48	1,24	1,14	-	0,82	-	-	-	-
355	1,62	1,37	1,13	1,04	-	0,74	-	-	-	-
280	1,51	1,27	1,06	-	-	-	-	-	-	-

size **100**

n <sub>worm</sub> <sup>1)</sup> min <sup>-1</sup>	u <sub>worm</sub>									
	7	10	13	16	20	25	32	40	50	63
1 400	-	9,8	8,5	7,8	7,2	5,7	5,1	-	-	-
1 120	-	8,5	7,3	6,6	6,2	4,84	4,32	-	-	-
900	-	7,2	6,2	5,6	5,3	4,12	3,67	3,4	-	-
710	-	6,2	5,3	4,8	4,45	3,5	3,11	2,87	-	-
560	-	5,3	4,49	4,08	3,79	2,97	2,64	2,44	-	-
450	-	4,59	3,9	3,54	3,3	2,56	2,3	-	-	-
355	-	4,02	3,41	3,09	2,89	2,24	2,01	-	-	-
280	-	3,55	3,01	2,76	2,57	1,99	1,79	-	-	-
224	-	3,18	2,69	2,44	-	1,78	1,59	-	-	-
180	-	2,88	2,42	2,21	-	1,6	-	-	-	-
140	-	2,52	2,12	-	-	1,4	-	-	-	-
112	-	2,25	1,9	-	-	-	-	-	-	-

size **160, 161**

n <sub>worm</sub> <sup>1)</sup> min <sup>-1</sup>	u <sub>worm</sub>									
	7	10	13	16	20	25	32	40	50	63
1 400	-	23,4	21,8	18,9	17,4	16,1	12,5	11,4	10,3	9,3
1 120	-	20,2	18,9	16,3	14,9	13,8	10,8	9,7	8,7	7,8
900	-	17,4	16,1	13,9	12,7	11,8	9,1	8,3	7,5	6,7
710	-	15	13,8	11,8	10,8	10	7,7	7	6,3	5,7
560	-	12,8	11,8	10,1	9,2	8,5	6,6	6	5,4	4,82
450	-	11,1	10,2	8,7	8	7,4	5,7	5,1	4,67	4,17
355	-	9,6	8,8	7,5	6,9	6,4	4,81	4,44	4,05	3,65
280	-	8,5	7,8	6,7	6,1	5,6	4,32	3,94	3,6	-
224	-	7,6	7	5,9	5,4	5	3,86	3,51	3,23	-
180	-	6,9	6,3	5,4	4,86	4,49	3,48	3,16	2,89	-
140	-	6	5,5	4,63	4,26	-	3,02	2,78	2,32	-
112	-	5,4	4,92	4,16	3,81	-	2,71	2,5	-	-
90 <sup>2)</sup>	-	4,81	4,42	3,74	3,43	-	2,46	2,25	-	-

size **250**

n <sub>worm</sub> <sup>1)</sup> min <sup>-1</sup>	u <sub>worm</sub>									
	7	10	13	16	20	25	32	40	50	63
1 400	-	-	-	48,5	41,2	39,4	35,5	27,3	25,7	23,2
1 120	-	-	-	42,2	36	34	30,2	23,8	22,1	19,7
900	-	-	-	36,8	31	29,6	25,9	20,4	18,9	16,8
710	-	-	-	31,2	26,4	25	22,2	17,3	16	14,4
560	-	-	-	26,9	22,8	21,4	18,8	14,9	13,6	12,2
450	-	-	-	23,4	19,7	18,6	16,3	12,8	11,8	10,6
355	-	-	-	20,2	17	15,9	14	11	10,1	9,1
280	-	-	-	17,7	14,9	14	12,3	9,6	8,9	8
224	-	-	-	15,8	13,1	12,4	11	8,5	7,9	7,2
180	-	-	-	14,2	11,8	11,1	9,8	7,7	7,1	6,4
140	-	-	-	12,5	10,3	9,8	-	6,7	6,2	-
112	-	-	-	11	9,1	8,6	-	5,9	5,6	-
90 <sup>2)</sup>	-	-	-	9,9	8,3	7,8	-	5,4	5	-

1) For worm speed n<sub>worm</sub> intermediate between two stated values (n<sub>sup</sub>, n<sub>inf</sub>), select the nearest lower value or interpolate: P<sub>tN-x</sub> = (P<sub>tN-n sup</sub> - P<sub>tN-n inf</sub>) · (n<sub>worm</sub> - n<sub>inf</sub>) / (n<sub>sup</sub> - n<sub>inf</sub>) + P<sub>tN-n inf</sub>  
 2) For n<sub>worm</sub> < 90 min<sup>-1</sup>, consult us.

Service factor  $f_s$  takes into account the different running conditions (nature of load, running time, frequency of starting, other considerations) which must be referred to when performing calculations of gear reducer selection and verification.

The powers and torques shown in the catalogue are nominal (i.e. valid for  $f_s = 1$ ) for gear reducers, corresponding to the  $f_s$  indicated for gearmotors.

Service factor based: on the nature of load and running time (this value is to be multiplied by the values shown in the tables alongside).

Service factor based on frequency of starting referred to the nature of load.

Nature of load of the driven machine		Running time [h]				
Ref.	Description	3 150 ≤ 2 h/d	6 300 2 ÷ 4 h/d	12 500 4 ÷ 8 h/d	25 000 8 ÷ 16 h/d	50 000 16 ÷ 24 h/d
<b>a</b>	<b>Uniform</b>	0,67	0,85	1	1,25	1,6
<b>b</b>	<b>Moderate overloads</b> (1,6 × normal)	0,85	1,06	1,25	1,05	1,25
<b>c</b>	<b>Heavy overloads</b> (2,5 × normal)	1	1,25	1,5	1,9	2,36

Load ref.	Frequency of starting z [starts/h]							
	4	8	16	32	63	125	250	500
<b>a</b>	1	1,06	1,12	1,18	1,25	1,32	1,4	1,5
<b>b</b>	1	1	1,06	1,12	1,18	1,25	1,32	1,4
<b>c</b>	1	1	1	1,06	1,12	1,18	1,25	1,32

Details of service factor and considerations.

Given  $f_s$  values are valid for:

- electric motor with cage rotor, direct on-line starting up to 9,2 kW, star-delta starting for higher power ratings; for direct on-line starting above 9,2 kW or for brake motors, select  $f_s$  according to a frequency of starting double the actual frequency; for internal combustion engines multiply  $f_s$  by 1,25 (multicylinder) or 1,5 (single-cylinder);
- maximum time on overload 15 s; on starting 3 s; if over and/or subject to heavy shock effect, consult us;
- a whole number of overload cycles (or start) **imprecisely** completed in 1, 2, 3 or 4 revolutions of low speed shaft; if **precisely** a continuous overloads should be assumed;
- **standard** level of reliability; if a **higher** degree of reliability is required (particularly difficult maintenance conditions, key importance of gear reducer to production, personnel safety, etc.) multiply  $f_s$  by **1,25 ÷ 1,4**.

Motors having a starting torque not exceeding nominal values (star-delta starting, particular types of motor operating on direct current, and single-phase motors), and particular types of coupling between gear reducer and motor, and gear reducer and driven machine (flexible, centrifugal, fluid and safety couplings, clutches and belt drives) affect service factor favourably, allowing its reduction in certain heavy-duty applications; consult us if need be.

## a - Gear reducer

### Determining the gear reducer size

- Make available all necessary data: required output power  $P_2$  of gear reducer, speeds  $n_2$  and  $n_1$ , running conditions (nature of load, running time, frequency of starting  $z$ , other considerations) with reference to ch. 3.3.
- Determine service factor  $f_s$  on the basis of running conditions (ch. 3.3).
- Select the gear reducer size (also, the train of gears and transmission ratio  $i$  at the same time) on the basis of  $n_2$ ,  $n_1$  and of a power  $P_{N2}$  greater than or equal to  $P_2 \cdot f_s$  (ch. 3.5).
- Calculate power  $P_1$  required at input side of gear reducer using — the formula  $\frac{P_2}{\eta}$ , where  $\eta = \frac{P_{N2}}{P_{N1}}$  is the efficiency of the gear reducer (ch. 3.5).

When for reasons of motor standardization, power  $P_1$  applied at input side of gear reducer turns out to be higher than the power required (considering motor/gear reducer efficiency), it must be certain that this excess power applied will never be required, and frequency of starting  $z$  is so low as not to affect service factor (ch. 3.3).

Otherwise, make the selection by multiplying  $P_{N2}$  by  $\frac{P_1 \text{ applied}}{P_1 \text{ required}}$

Calculations can also be made on the basis of torque instead of power; this method is even preferable for low  $n_2$  values.

### Verifications

- Verify possible radial loads  $F_{r1}$ ,  $F_{r2}$  and axial load  $F_{a2}$  by referring to instructions and values given in ch. 3.11 and 3.13.
- When the load chart is available, and/or there are overloads — due to starting on full load (mainly for high inertias and low transmission ratios), braking, shocks, irreversible or with low reversibility gear reducers in which the wormwheel becomes driving member due to the driven machine inertia, applied power higher than that required, other static or dynamic causes — verify that the maximum torque peak (ch. 3.13) is always less than  $M_{2max}$  (ch. 3.5); if it is higher or cannot be evaluated, in the above cases, install a safety device so that  $M_{2max}$  will never be exceeded.
- When nominal thermal power  $P_{tN}$  is indicated in red in ch. 3.5, verify that  $P_1 \leq P_t$  (ch. 3.2).

## b - Gearmotor

### Determining the gearmotor size

- Make available all necessary data: required output power  $P_2$  of gearmotor, speed  $n_2$ , running conditions (nature of load, running time, frequency of starting  $z$ , other considerations) with reference to ch. 3.3.
- Determine service factor  $f_s$  on the basis of running conditions (ch. 3.3).
- Select the gearmotor size on the basis of  $n_2$ ,  $f_s$ ,  $P_2$  (ch. 3.7).

When for reasons of motor standardization, power  $P_2$  available in catalog is much greater than that required, the gearmotor can be selected on the

basis of a lower service factor ( $f_s \cdot \frac{P_2 \text{ required}}{P_2 \text{ available}}$ )

provided it is certain that this excess power available will never be required and frequency of starting  $z$  is low enough not to affect service factor (ch. 3.3).

Calculations can also be made on the basis of torque instead of power; this method is even preferable for low  $n_2$  values.

### Verifications

- Verify possible radial load  $F_{r2}$  and axial load  $F_{a2}$  referring to directions and values given in ch. 3.12.
- For the motor, verify frequency of starting  $z$  when higher than that normally permissible, referring to directions and values given in ch. 2b; this will normally be required for brake motors only.
- Verify, in case of **motors supplied by the customer**, that the **static bending moment  $M_b$**  generated by motor weight on the counter flange of gear reducer is lower than the value allowed  $M_{bmax}$  stated in the ch. 3.13.  
**Loads higher than permissible loads may be present in dynamical applications** where the gearmotor is subjected to translations, rotations or oscillations (e.g.: **shaft mounting arrangements**): consult us for the study of every specific case

- When a load chart is available, and/or there are overloads — due to starting on full load (especially with high inertias and low transmission ratios), braking, shocks, irreversible or with low reversibility gear reducers in which the wormwheel becomes driving member due to the driven machine inertia, other static or dynamic causes — verify that the maximum torque peak (ch. 3.13) is always less than  $M_{2max}$  (ch. 3.5); if it is higher or cannot be evaluated, in the above instances, install suitable safety devices so that  $M_{2max}$  will never be exceeded.  $M_{2max}$  value can be read off in ch. 3.5 against the corresponding speed  $n_2$  and transmission ratio  $i$  of the worm gear pair.
- When nominal thermal power  $P_{tN}$  is indicated in red in ch. 3.7, verify that  $P_1 \leq P_t$  (ch. 3.2).

## c - Combined gear reducer and gearmotor units

Combined units are obtained by coupling together **normal single** gear reducers and/or gearmotors.

### Determining the final gear reducer size

- Make available all necessary data relating to the output of the final gear reducer: required torque  $M_2$  speed  $n_2$ , running conditions (nature of load, running time, frequency of starting  $Z$ , other considerations) with reference to ch. 3.3.
- Determine service factor  $f_s$  on the basis of running conditions (ch. 3.3) and of  $n_2$  (see \*, \*\* ch. 3.9).
- Select the final gear reducer size and the corresponding efficiency  $\eta$  (ch. 3.9, table A), on the basis of  $n_2$  and a torque value  $M_{N2}$  greater than or equal to  $M_2 \cdot f_s$  (the  $\eta$  value shown can be taken as valid even if the final gear reducer's train of gears is type IV).  
For  $f_s < 1$  verify that  $M_2 \leq M_{2\text{ Size}}$ .

### Determining the type of combined unit

- Select the final gear reducer basic reference, and the type and size of initial gear reducer or gearmotor (ch. 3.9 table B), on the basis of the final gear reducer size, and of the type of combined unit selected.

When selecting the type of unit, refer to the drawings in table B bearing in mind the following considerations:

**gear reducer:** gives greater operational flexibility; stress deriving from starting and heavy duty can be diminished thanks to the possibility of locating couplings (flexible, centrifugal, fluid, safety or friction type), belt drives, etc. between gear reducer and motor;

**gearmotor:** provides a more compact and economical solution compared to the equivalent gear reducer combined unit;

combined units **R V** + R V or MR V; **R V** + R IV or MR IV: input and output shafts can be either parallel or orthogonal, overall dimensions are kept to a minimum, especially within the plane perpendicular to the low speed shafts; these units are normally irreversible; the latter two types give higher transmission ratios than the former two types as well as higher efficiency, with the same transmission ratio;

combined units **MR V** + R 2l, 3l or MR 2l, 3l: input and output shafts are orthogonal, overall dimensions kept at minimum along the direction of the low speed shaft; high efficiency;

combined units **MR IV** + R 2l, 3l or MR 2l, 3l: the same as above but with the possibility of higher transmission ratios, and with overall dimensions of the initial gear reducer or gearmotor contained within those planes defined by the mounting feet.



## Selection of initial gear reducer or gearmotor

– Calculate the speed  $n_2$  and the required power  $P_2$  at the initial gear reducer or gearmotor output, using the following formulae:

$$n_2 \text{ initial} = n_2 \text{ final} \cdot i \text{ final}$$

$$P_2 \text{ initial} = \frac{M_2 \text{ final} \cdot n_2 \text{ final}}{955 \cdot \eta \text{ final}} [\text{kW}]$$

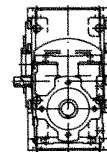
- In the case of gear reducer, establish input speed  $n_1$  at the input of the initial gear reducer.
- Make the selection of initial gear reducer or gearmotor as shown in ch. 3.4, paragraph a) or b) of this catalog (in the case of worm gear reducers and gearmotors), or of catalogue E (in the case of coaxial gear reducers and gearmotors), bearing in mind that sizes are pre-established (and cannot be changed on account of couplings being standard) and that it is not necessary to verify the service factor.

## Designation for ordering

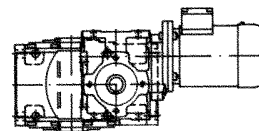
When ordering combined units, the single gear reducers or gearmotors must be designed **separately**, as indicated in ch. 3.1 paragraph a) or b), of this catalog (for the final gear reducer and initial worm gear reducer or gearmotor) or of catalog E (for initial coaxial gear reducer or gearmotor), bearing in mind the following):

- for all combined units, insert the words **coupled with** between the final gear reducer designation and that of the initial gear reducer or gearmotor;
- in the case of **R V** + R V or MR V and **R V** + R IV or MR IV, select the initial gear reducer or gearmotor stating the coupling **position** where applicable (ch. 3.10);
- when ordering **MR V** + R 2l, 3l or MR 2l, 3l and **MR IV** + R 2l, 3l or MR 2l, 3l always add the words **without motor** to the final gear reducer designation and select for the initial gear reducer or gearmotor **oversized B5 flange** design (for size 63 also add – **Ø 28**); in case of initial gear reducer or gearmotor size 32 or 40 select **FC1A** flange design;
- in order to make easier the individualization of mounting position of initial gear reducer or gearmotor see ch. 3.10.

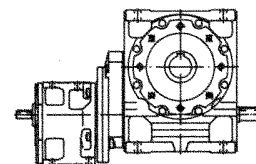
E.g: R V 100 UO2A/25  
coupled with  
R V 50 UO3A/32



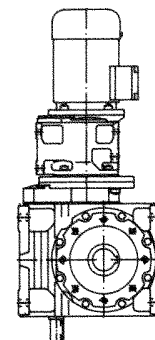
R V 100 UO2A/25 mounting position V5  
coupled with  
MR V 50 UO3A – 14 160 – 50 pos. 3  
HB 71 A 4 230.400 B5



MR V 200 UO2A – 48 350 – 32 without motor  
coupled with  
R 2l 100 UC2A/29,3 oversized B5 flange



MR IV 200 UO2A – 138 300 – 81,8 without motor, mounting  
position B6, double extension low speed shaft  
coupled with  
MR 3l 80 UC2A – 19 200 – 49,8 mounting position V5  
oversized B5 flange  
HB3 80A 4 230.400 B5



## Considerations on selection

### Motor power

Taking into account the efficiency of the gear reducer, and other drives — if any — motor power is to be as near as possible to the power rating required by the driven machine: accurate calculation is therefore recommended.

The power required by the machine can be calculated, seeing that it is related directly to several requirements of the work to be carried out, to friction (starting, sliding or rolling friction) and inertia (particularly when mass and/or acceleration or deceleration are considerable). It can also be determined experimentally on the basis of tests, comparison with existing applications, or readings taken with amperometers or wattmeters.

An oversized motor would involve: a greater starting current and consequently larger fuses and heavier cable; a higher running cost as power factor ( $\cos \varphi$ ) and efficiency would suffer; greater stress on the drive, causing danger of mechanical failure, drive being normally proportionate to the power rating required by the machine, not to motor power.

Only high values of ambient temperature, altitude, frequency of starting or other particular conditions require an increase in motor power.

### Driving machines with high kinetic energy

When driving machines with high inertias and/or speeds, **avoid** the use of **irreversible** gear reducers or gearmotors, rather select a train of gears with higher efficiency (e.g. IV, 2IV in place of V), keeping the same transmission ratio, as stopping and braking can cause very high overloads (cap. 3.13).

### Drives with low input speed ( $n_1 < 355 \text{ min}^{-1}$ )

Wherever possible select the following transmission  $i=20$  for sizes 32 ... 50,  $i=25$  for sizes 63 ... 100,  $i=32$  for sizes 125 ... 200,  $i=40$  for size 250, these being the ratios capable of transmitting highest torque (for performance figures see table A ch. 11; for sizes 32 and 40, consult us).

### Input speed

For  $n_1$  higher than  $1\,400 \text{ min}^{-1}$ , **power** and **torque** ratings relating to a given transmission ratio vary as shown in the table alongside. In this case no loads should be imposed on the high speed shaft end.

For variable  $n_1$ , the selection should be carried out on the basis of  $n_{1 \text{ max}}$ ; but it should also be verified on the basis of  $n_{1 \text{ min}}$ .

When there is a belt drive between motor and gear reducer, different input speeds  $n_1$ , should be examined in order to select the most suitable unit from engineering and economy standpoints alike (our catalog favours this method of selection as it shows a number of input speed values  $n_1$  relating to a determined output speed  $n_{N2}$  in the same section).

Input speed should not be higher than  $1\,400 \text{ min}^{-1}$ , unless conditions make it necessary; better to take advantage of the transmission, and use an input speed lower than  $900 \text{ min}^{-1}$ .

$n_1$ $\text{min}^{-1}$	$P_{N2}$	$M_{N2}$
<b>2 800</b>	1,4	0,71
<b>2 240</b>	1,25	0,8
<b>1 800</b>	1,12	0,9
<b>1 400</b>	1	1

### Operation at 60 Hz

When motor is supplied at 60 Hz frequency (ch. 2 b), the gearmotor specifications vary as follows.

- Speed  $n_2$  increases by 20%.
- Power  $P_1$  may either remain constant or increase (ch. 2 b).
- Torque  $M_2$  and service factor  $f_s$  vary as follows:

$$M_{2 \text{ at } 60 \text{ Hz}} = M_{2 \text{ at } 50 \text{ Hz}} \cdot \frac{P_{1 \text{ at } 60 \text{ Hz}}}{1,2 \cdot P_{1 \text{ at } 50 \text{ Hz}}}$$

$$f_{s \text{ at } 60 \text{ Hz}} = f_{s \text{ at } 50 \text{ Hz}} \cdot \frac{1,12 \cdot P_{1 \text{ at } 50 \text{ Hz}}}{P_{1 \text{ at } 60 \text{ Hz}}}$$

$n_{N2}$ $\frac{1}{\min^{-1}}$	$n_1$	Train of gears $i$	P [kW] M [daN m]	Gear reducer size														
				P		M		P		M		P		M				
				32	40	50	63	64	80	81	100	125	126	160	161	200	250	
140	1 400	V 10	$P_{N1}$	0,57	1,01	1,79	3,02	3,59	5,5	6,6	10,6	16,7	19,8	29,9	35,6	—	—	
			$P_{N2}$	0,48	0,87	1,55	2,68	3,19	4,96	5,9	9,5	15,1	18	27,3	32,5	—	—	
			$M_{N2}$	3,29	5,9	10,6	18,3	21,7	33,9	40,3	65	103	123	186	222	—	—	
			$M_{2max}$	5,9	10,5	19,4	33,2	36,1	63	68	120	188	204	342	394	—	—	
125	1 250	V 10	$P_{N1}$	0,53	0,94	1,66	2,82	3,36	5,2	6,2	9,9	15,7	18,7	28,1	33,5	—	—	
			$P_{N2}$	0,44	0,8	1,44	2,5	2,97	4,65	5,5	8,9	14,2	16,9	25,6	30,5	—	—	
			$M_{N2}$	3,4	6,1	11	19,1	22,7	35,6	42,3	68	109	129	196	233	—	—	
			$M_{2max}$	6,2	11,2	19,9	35,1	38,1	65	70	124	195	212	357	410	—	—	
112	1 400	V 13	$P_{N1}$	0,47	0,82	1,49	2,44	2,9	4,55	5,4	9	14,4	17,2	26,6	31,6	47,9	—	
			$P_{N2}$	0,39	0,69	1,27	2,12	2,52	3,99	4,75	8	13	15,4	24	28,6	43,6	—	
			$M_{N2}$	3,47	6,1	11,3	18,8	22,3	35,4	42,1	71	115	137	213	254	386	—	
				$M_{2max}$	6,2	11,3	20,6	35,1	38,1	66	71	128	203	220	380	413	716	
		1 120	V 10	$P_{N1}$	0,49	0,88	1,55	2,64	3,14	4,91	5,8	9,3	14,9	17,7	26,5	31,5	—	—
	$P_{N2}$			0,41	0,75	1,34	2,33	2,77	4,37	5,2	8,4	13,4	16	24	28,6	—	—	
$M_{N2}$	3,51			6,4	11,4	19,9	23,6	37,3	44,3	71	115	136	205	244	—	—		
			$M_{2max}$	6,4	11,5	20,5	37	40,2	67	73	128	203	220	371	427	—	—	
100	1 250	V 13	$P_{N1}$	0,43	0,76	1,39	2,28	2,72	4,25	5,1	8,5	13,6	16,1	25	29,8	45,4	—	
			$P_{N2}$	0,36	0,64	1,18	1,97	2,35	3,71	4,41	7,5	12,1	14,4	22,6	26,9	41,2	—	
			$M_{N2}$	3,58	6,4	11,8	19,6	23,3	36,8	43,8	74	121	143	225	267	409	—	
				$M_{2max}$	6,4	11,6	21,1	36,9	40,1	69	75	135	219	238	412	448	748	
		1 000	V 10	$P_{N1}$	0,45	0,82	1,44	2,46	2,92	4,57	5,4	8,7	14	16,7	24,7	29,4	—	—
	$P_{N2}$			0,38	0,69	1,23	2,16	2,57	4,05	4,82	7,8	12,6	15	22,4	26,7	—	—	
$M_{N2}$	3,62			6,6	11,8	20,6	24,5	38,7	46,1	74	120	143	214	255	—	—		
			$M_{2max}$	6,6	11,8	21	38,2	41,5	70	77	134	214	233	393	452	—	—	
90	1 400	V 16	$P_{N1}$	0,41	0,73	1,3	2,14	2,55	4,03	4,79	7,5	12	14,3	22,5	26,8	41,3	74	
			$P_{N2}$	0,34	0,61	1,1	1,83	2,18	3,49	4,15	6,6	10,6	12,6	20,1	23,9	37,3	67	
			$M_{N2}$	3,67	6,6	12	20	23,8	38,1	45,3	72	116	138	219	261	407	732	
				$M_{2max}$	6,1	11,1	20,2	35,9	39	68	73	127	206	224	403	437	705	1273
		1 120	V 13	$P_{N1}$	0,4	0,71	1,3	2,14	2,55	3,97	4,73	8	12,8	15,2	23,6	28,1	43,1	—
	$P_{N2}$			0,33	0,6	1,1	1,84	2,19	3,45	4,11	7	11,4	13,5	21,3	25,3	39	—	
$M_{N2}$	3,7			6,6	12,2	20,4	24,3	38,3	45,5	78	126	150	236	281	433	—		
			$M_{2max}$	6,6	11,9	21,7	38,5	41,8	72	79	141	227	246	427	464	781		
	900	V 10	$P_{N1}$	0,42	0,77	1,35	2,3	2,74	4,28	5,1	8,2	13,2	15,8	23,3	27,7	—	—	
$P_{N2}$			0,35	0,65	1,15	2,01	2,39	3,78	4,5	7,3	11,9	14,2	21	25	—	—		
$M_{N2}$			3,73	6,9	12,2	21,3	25,4	40,1	47,7	78	126	150	223	265	—	—		
			$M_{2max}$	6,7	12,1	21,5	39,4	42,7	74	80	140	225	245	407	468	—	—	
80	1 250	V 16	$P_{N1}$	0,38	0,68	1,22	2	2,38	3,78	4,5	7,1	11,3	13,4	21,2	25,2	38,8	69	
			$P_{N2}$	0,31	0,56	1,02	1,7	2,03	3,26	3,88	6,2	9,9	11,8	18,8	22,4	35	63	
			$M_{N2}$	3,81	6,9	12,5	20,8	24,8	39,8	47,4	75	121	144	230	274	428	770	
				$M_{2max}$	6,4	11,5	20,7	37	40,2	70	76	136	213	232	418	454	736	1329
		1 000	V 13	$P_{N1}$	0,37	0,66	1,21	2	2,38	3,71	4,42	7,4	12	14,3	22,1	26,4	40,7	—
	$P_{N2}$			0,31	0,55	1,02	1,71	2,03	3,21	3,82	6,5	10,7	12,7	19,9	23,7	36,7	—	
$M_{N2}$	3,82			6,8	12,6	21,2	25,2	39,9	47,4	81	133	158	247	294	456	—		
			$M_{2max}$	6,8	12,3	22,2	39,6	43	74	80	145	234	254	442	481	814		
	800	V 10	$P_{N1}$	0,39	0,71	1,25	2,12	2,52	3,96	4,71	7,6	12,4	14,7	21,7	25,8	—	—	
$P_{N2}$			0,32	0,59	1,06	1,85	2,2	3,48	4,14	6,8	11,1	13,2	19,5	23,3	—	—		
$M_{N2}$			3,85	7,1	12,6	22	26,2	41,5	49,4	81	132	157	233	278	—	—		
			$M_{2max}$	7,1	12,7	22,8	40,4	43,9	76	83	143	233	253	429	493	—	—	
71	1 400	V 20	$P_{N1}$	0,38	0,67	1,18	1,7	2,03	3,14	3,73	6,2	10,1	12,1	18,6	22,1	36,2	62	
			$P_{N2}$	0,29	0,52	0,94	1,44	1,71	2,68	3,19	5,3	8,9	10,6	16,4	19,5	32,2	56	
			$M_{N2}$	4,01	7,1	12,8	19,6	23,3	36,6	43,5	73	121	144	224	266	439	759	
				$M_{2max}$	6,8	12,2	22,3	34,6	37,5	65	71	126	209	227	401	436	744	1308
		1 120	V 16	$P_{N1}$	0,36	0,64	1,15	1,87	2,23	3,55	4,23	6,6	10,6	12,6	20	23,8	36,6	65
	$P_{N2}$			0,29	0,52	0,96	1,59	1,89	3,05	3,63	5,8	9,3	11,1	17,7	21,1	33	59	
$M_{N2}$	3,95			7,1	13,1	21,6	25,7	41,6	49,5	79	127	151	242	288	450	808		
			$M_{2max}$	6,6	12	21,2	38,1	41,4	72	78	139	220	239	432	470	767		
	900	V 13	$P_{N1}$	0,35	0,62	1,13	1,87	2,23	3,49	4,15	7	11,4	13,5	20,8	24,8	38,6	—	
$P_{N2}$			0,29	0,51	0,94	1,59	1,89	3	3,57	6,1	10,1	12	18,7	22,2	34,7	—		
$M_{N2}$			3,93	7	13	22	26,1	41,4	49,3	84	139	165	257	306	479	—		
			$M_{2max}$	6,9	12,5	22,7	39,7	43,2	75	81	149	242	263	457	497	847		
	710	V 10	$P_{N1}$	0,36	0,65	1,16	1,95	2,33	3,65	4,35	7,1	11,5	13,7	20,2	24	—	—	
$P_{N2}$			0,3	0,54	0,97	1,69	2,01	3,2	3,81	6,3	10,3	12,2	18,2	21,6	—	—		
$M_{N2}$			3,98	7,3	13,1	22,8	27,1	43	51	84	138	165	244	291	—	—		
			$M_{2max}$	7,2	13	23,3	41,3	44,9	78	85	147	240	260	442	509	—	—	

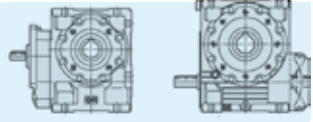
Values in red state nominal thermal power  $P_{tn}$  (ambient temperature 40 °C, continuous duty see ch. 3.2).

For  $n_1$  higher than 1 400 min<sup>-1</sup> or lower than 355 min<sup>-1</sup> see ch. 3.4 and page 32.

1) Values given for train of gears **IV** are nominal; see page 93 for effective transmission ratios.

2)  $M_{2max}$  represents maximum torque peak the gear reducer will withstand.

$n_{N2}$ $\frac{n_1}{\text{min}^{-1}}$	Train of gears $i$	P [kW] M [daN m]	Gear reducer size																							
			1)		2)		32	40	50	63	64	80	81	100	125	126	160	161	200	250						
63	1 250	V 20	$P_{N1}$	0,35	0,63	1,1	0,9	1,59	1,89	1,6	2,93	2,4	3,49	2,4	5,8	9,6	11,4	17,4	20,8	16	34,2	25	59	38		
			$P_{N2}$	0,27	0,49	0,87		1,33	1,58	2,49	2,96	4,98	8,3	9,9	15,3	18,2	27,9	30,3	46,3	79,8						
			$M_{N2}$	4,15	7,4	13,4		20,3	24,2	38	45,3	76	127	151	234	279	415	451	790	1366						
			$M_{2max}$	6,9	12,7	22,8		36,7	39,9	69	75	129	224	243	415	451	790	1366								
	1 000	V 16	$P_{N1}$	0,33	0,59	1,07		1,75	2,08	1,6	3,31	2,4	3,93	2,4	6,2	10	11,8	9,6	18,7	15	22,3	15	34,5	25	61	39
			$P_{N2}$	0,27	0,48	0,89		1,47	1,75	2,82	3,36	5,4	8,7	10,3	16,5	19,7	30,1	30,9	47,3	84,9						
			$M_{N2}$	4,08	7,3	13,6		22,4	26,7	43,2	51	82	133	158	253	301	503	503	843	1441						
			$M_{2max}$	6,8	12,2	22,3		39,2	42,6	74	80	145	228	247	463	503	843	843	1441							
	800	V 13	$P_{N1}$	0,32	0,57	1,04		1,74	2,07	1,5	3,24	2,4	3,86	2,4	6,5	10,6	12,6	9,4	19,5	15	23,2	15	36,1	23	—	—
			$P_{N2}$	0,26	0,47	0,86		1,47	1,75	2,78	3,3	5,6	9,3	11,1	17,4	20,7	32,1	32,4	50,3	90,7						
			$M_{N2}$	4,07	7,3	13,4		22,8	27,1	43,1	51	87	145	172	270	321	518	518	907							
			$M_{2max}$	7,2	12,9	23,9		42	45,6	79	86	152	257	280	477	518	907	907								
630	V 10	$P_{N1}$	0,33	0,6	1,06		1,8	2,14	1,7	3,37	2,6	4,01	2,6	6,5	10,7	9	12,7	9	18,8	14	22,3	14	—	—		
		$P_{N2}$	0,27	0,5	0,89		1,55	1,85	2,94	3,5	5,8	9,5	11,3	16,8	20	30,3	30,3	46,3	79,8							
		$M_{N2}$	4,09	7,5	13,5		23,5	28	44,5	53	87	144	171	255	303	503	503	843	1441							
		$M_{2max}$	7,5	13,6	23,7		43,5	47,2	80	87	150	247	268	463	503	843	843	1441								
56	1 400	V 25	$P_{N1}$	0,3	0,55	0,99		1,61	1,92	1,3	3,04	2,1	3,61	2,1	5,9	8,4	9,9	15,3	18,2	25	28,4	25	51	39		
			$P_{N2}$	0,23	0,42	0,77		1,29	1,53	2,47	2,94	4,89	7,2	8,6	13,3	15,9	27,0	27,0	42,6	74,5						
			$M_{N2}$	3,89	7,2	13,2		21,9	26,1	42,2	50	83	123	146	227	270	426	426	745	1341						
			$M_{2max}$	6,6	12,3	22,4		38,5	41,9	73	80	148	217	235	397	432	745	745	1341							
	1 120	V 20	$P_{N1}$	0,33	0,59	1,04	0,8	1,48	1,76	2,74	3,26	2,3	5,4	9	10,7	16,4	19,5	15	32,4	23	55	36	—	—	—	
			$P_{N2}$	0,25	0,45	0,81		1,23	1,47	2,32	2,76	4,65	7,8	9,3	14,3	17,1	28,6	28,6	49,2	83,8						
			$M_{N2}$	4,28	7,7	13,9		21	25	39,5	47	79	133	158	245	291	488	488	836	1424						
			$M_{2max}$	7,1	13,2	23,3		37,8	41	71	77	132	231	251	429	466	836	836	1424							
	900	V 16	$P_{N1}$	0,31	0,55	1		1,64	1,95	1,5	3,1	2,3	3,68	2,3	5,8	9,4	11,2	8,9	17,6	14	21	14	32,6	23	58	37
			$P_{N2}$	0,25	0,45	0,83		1,37	1,63	2,63	3,13	5	8,2	9,7	15,5	18,4	29,2	29,2	49,5	88,9						
			$M_{N2}$	4,21	7,6	14		23,2	27,6	44,6	53	85	139	165	263	313	495	495	855	1498						
			$M_{2max}$	7,1	12,8	22,8		40,3	43,8	76	83	146	235	255	477	518	855	855	1498							
710	V 13	$P_{N1}$	0,3	0,53	0,95		1,61	1,92	1,5	3,01	2,3	3,58	2,3	6	9,8	11,7	8,7	18,2	14	21,7	14	33,7	21	—	—	
		$P_{N2}$	0,24	0,43	0,79		1,36	1,61	2,56	3,05	5,2	8,6	10,3	16,2	19,3	30,2	30,2	52,8	92,9							
		$M_{N2}$	4,22	7,5	13,8		23,7	28,2	44,8	53	89	151	180	283	337	528	528	929								
		$M_{2max}$	7,3	13,3	24,3		42,9	46,6	82	89	156	265	287	494	528	929	929									
560	V 10	$P_{N1}$	0,3	0,55	0,98		1,66	1,97	1,6	3,11	2,5	3,7	2,5	6	9,9	8,3	11,8	8,3	17,5	13	20,8	13	—	—		
		$P_{N2}$	0,25	0,45	0,82		1,43	1,7	2,7	3,21	5,3	8,8	10,4	15,6	18,6	29,2	29,2	49,5	88,9							
		$M_{N2}$	4,21	7,7	13,9		24,3	29	46	55	90	149	178	266	316	495	495	855	1498							
		$M_{2max}$	7,7	13,9	24,9		44,3	48,2	82	89	153	253	275	476	518	855	855	1498								
50	1 250	V 25	$P_{N1}$	0,28	0,52	0,92		1,51	1,79	1,2	2,85	1,9	3,39	1,9	5,5	7,8	9,3	14,2	17	26,9	21	48,4	37	—	—	
			$P_{N2}$	0,21	0,39	0,71		1,19	1,42	2,3	2,74	4,55	6,7	8	12,4	14,8	23,7	23,7	45,2	82,1						
			$M_{N2}$	4,03	7,5	13,6		22,8	27,1	44	52	87	128	152	237	282	452	452	783	1395						
			$M_{2max}$	6,9	12,5	22,9		40,9	44,5	76	82	153	223	243	410	446	783	783	1395							
	1 000	V 20	$P_{N1}$	0,31	0,54	0,97	0,8	1,38	1,64	2,55	3,04	2,2	5,1	8,4	10	15,3	18,3	14	30,5	21	52	33	—	—	—	
			$P_{N2}$	0,23	0,42	0,75		1,14	1,36	2,15	2,55	4,33	7,3	8,6	13,4	15,9	26,8	26,8	46,3	88,4						
			$M_{N2}$	4,43	7,9	14,4		21,8	25,9	41	48,8	83	139	165	255	304	512	512	869	1509						
			$M_{2max}$	7,4	13,6	24,5		38,8	42,1	73	80	140	238	258	458	498	869	869	1509							
	800	V 16	$P_{N1}$	0,29	0,51	0,93		1,51	1,8	1,4	2,86	2,2	3,41	2,2	5,4	8,8	10,4	8,2	16,4	13	19,6	13	30,3	21	54	34
			$P_{N2}$	0,23	0,41	0,76		1,26	1,5	2,42	2,88	4,66	7,6	9	14,4	17,1	27,1	27,1	48,8	93,2						
			$M_{N2}$	4,35	7,8	14,5		24	28,6	46,2	55	89	145	172	275	327	517	517	876	1608						
			$M_{2max}$	7,3	13,2	23		42,3	46	81	88	152	245	266	491	534	876	876	1608							
630	V 13	$P_{N1}$	0,27	0,49	0,87		1,49	1,78	1,4	2,78	2,2	3,31	2,2	5,6	9,1	10,8	8	17	13	20,2	13	31,5	20	—	—	
		$P_{N2}$	0,22	0,39	0,72		1,25	1,48	2,36	2,81	4,79	8	9,5	15	17,9	28,2	28,2	49,5	88,9							
		$M_{N2}$	4,34	7,8	14,2		24,6	29,2	46,5	55	94	157	187	296	352	555	555	951								
		$M_{2max}$	7,6	13,9	25,2		45	48,9	85	92	161	272	295	513	575	951	951									
500	V 10	$P_{N1}$	0,28	0,5	0,9		1,53	1,82	1,5	2,86	2,3	3,41	2,3	5,6	9,1	7,7	10,9	7,7	16,3	12	19,4	12	—	—		
		$P_{N2}$	0,23	0,41	0,75		1,31	1,56	2,48	2,95	4,88	8,1	9,6	14,5	17,2	29,2	29,2	49,5	88,9							
		$M_{N2}$	4,31	7,9	14,3		25	29,7	47,3	56	93	154	183	276	329	563	563									
		$M_{2max}$	7,9	14,5	25,7		46,4	50	85	92	161	265	287	490	534	951	951									
45	1 400	V 32	$P_{N1}$	0,24	0,44	0,75		1,26	1,5	1,2	2,35	1,8	2,79	1,8	4,63	7,4	8,8	13,4	16	13	25	19	37,8	—		
			$P_{N2}$	0,17	0,33	0,57		0,98	1,16	1,86	2,22	3,74	6,1	7,2	11,2	13,3	21,2	21,2	46,2	81,7						
	1 120	V 25	$M_{N2}$	3,81	7,1	12,4		21,3	25,4	40,7	48,4	82	133	158	245	291	462	462	817							
			$M_{2max}$	6,4	12	21,3		37,2	40,4	70	77	140	236	256	436	473	817	817	1287							
			$P_{N1}$	0,26	0,48	0,86		1,41	1,68	1,2	2,68	1,8	3,19	1,8	5,2	7,3	8,6	13,4	15,9	25,6	22	45,8	34	—	—	
			$P_{N2}$	0,2	0,36	0,66		1,11	1,32	2,15	2,56	4,24	6,2	7,4	11,6	13,8	22,4	22,4	40,5	86,3						
1 120	V 25	$M_{N2}$	4,17	7,7	14,1		23,7	28,2																		



$n_{N2}$   $n_1$ min <sup>-1</sup>	Train of gears i	P [kW] M [daN m]	Gear reducer size														
																	
			32	40	50	63	64	80	81	100	125	126	160	161	200	250	
45	900	V 20	P <sub>N1</sub>	0,29	0,51	0,91	1,29	1,53	2,39	2,85	4,78	7,9	9,4	14,4	17,2	28,8	49,4
			P <sub>N2</sub>	0,22	0,38	0,7	1,06	1,26	2	2,38	4,06	6,8	8,1	12,5	14,9	25,3	43,7
			M <sub>N2</sub>	4,58	8,2	14,9	22,5	26,7	42,4	50	86	144	172	265	316	536	928
			M <sub>2max</sub>	7,8	14,1	25	39,6	43	75	82	143	245	266	472	513	900	1595
	710	V 16	P <sub>N1</sub>	0,26	0,47	0,86	1,4	1,66	2,65	3,15	5,1	8,2	9,7	15,3	18,2	28,2	51
			P <sub>N2</sub>	0,21	0,37	0,7	1,15	1,37	2,22	2,64	4,32	7	8,4	13,3	15,9	25,1	45,4
			M <sub>N2</sub>	4,5	8,1	15	24,8	29,6	47,8	57	93	151	180	287	342	539	977
			M <sub>2max</sub>	7,5	13,6	24,3	43,1	46,9	83	90	157	256	278	505	549	897	1619
	560	V 13	P <sub>N1</sub>	0,25	0,45	0,8	1,38	1,64	2,58	3,07	5,2	8,4	10	15,8	18,8	29,5	—
			P <sub>N2</sub>	0,2	0,36	0,66	1,15	1,36	2,17	2,59	4,42	7,3	8,7	14	16,6	26,3	—
			M <sub>N2</sub>	4,46	8	14,6	25,4	30,3	48,2	57	98	163	194	309	368	583	—
			M <sub>2max</sub>	7,8	14,2	25,9	46,8	51	88	95	167	279	303	530	576	973	—
450	V 10	P <sub>N1</sub>	0,26	0,47	0,84	1,42	1,68	2,65	3,16	5,2	8,5	10,1	15,3	18,2	—	—	
		P <sub>N2</sub>	0,21	0,38	0,69	1,21	1,44	2,29	2,72	4,54	7,5	8,9	13,5	16,1	—	—	
		M <sub>N2</sub>	4,42	8,1	14,7	25,7	30,5	48,5	58	96	158	188	287	342	—	—	
		M <sub>2max</sub>	8,1	14,7	26,5	47,2	51	87	95	164	275	299	510	587	—	—	
40	1 250	V 32	P <sub>N1</sub>	0,23	0,41	0,71	1,17	1,39	2,19	2,61	4,33	7	8,3	12,6	15	23,6	35,7
			P <sub>N2</sub>	0,16	0,3	0,53	0,9	1,07	1,73	2,06	3,48	5,7	6,8	10,5	12,4	19,9	31,2
			M <sub>N2</sub>	3,93	7,3	13	22	26,2	42,2	50	85	139	165	256	304	487	763
			M <sub>2max</sub>	6,6	12,4	22	39,4	42,8	74	80	143	243	264	450	489	850	1335
	1 000	V 25	P <sub>N1</sub>	0,25	0,45	0,81	1,32	1,57	2,5	2,98	4,82	6,7	8	12,5	14,8	24,1	43
			P <sub>N2</sub>	0,18	0,33	0,61	1,03	1,22	1,99	2,37	3,92	5,7	6,8	10,7	12,8	21	37,9
			M <sub>N2</sub>	4,31	7,9	14,6	24,5	29,2	47,6	57	94	137	163	256	305	501	904
			M <sub>2max</sub>	7,4	13,4	24,2	43,9	47,6	81	88	162	240	261	436	473	863	1530
	800	V 20	P <sub>N1</sub>	0,27	0,47	0,84	1,19	1,41	2,21	2,63	4,45	7,4	8,8	13,4	16	26,8	46,1
			P <sub>N2</sub>	0,2	0,35	0,65	0,97	1,15	1,83	2,18	3,75	6,3	7,5	11,6	13,8	23,4	40,7
			M <sub>N2</sub>	4,7	8,4	15,4	23,1	27,5	43,8	52	90	150	178	277	330	559	972
			M <sub>2max</sub>	7,9	14,3	25,9	41,4	45	78	85	146	255	277	485	527	927	1653
630	V 16	P <sub>N1</sub>	0,24	0,43	0,79	1,28	1,53	2,44	2,9	4,69	7,6	9	14,2	16,9	26,2	46,9	
		P <sub>N2</sub>	0,19	0,34	0,64	1,05	1,26	2,03	2,42	3,96	6,5	7,7	12,3	14,7	23,2	42	
		M <sub>N2</sub>	4,61	8,3	15,4	25,6	30,4	49,3	59	96	157	187	299	355	562	1018	
		M <sub>2max</sub>	7,5	13,7	25,1	45,1	49	85	93	160	266	289	527	572	931	1683	
500	V 13	P <sub>N1</sub>	0,23	0,41	0,74	1,28	1,52	2,39	2,84	4,79	7,8	9,3	14,7	17,5	27,5	—	
		P <sub>N2</sub>	0,18	0,33	0,6	1,05	1,25	2	2,38	4,07	6,7	8	12,9	15,4	24,4	—	
		M <sub>N2</sub>	4,57	8,2	15	26,2	31,2	49,7	59	101	168	199	321	382	606	—	
		M <sub>2max</sub>	8,1	14,6	26,7	47,8	52	89	97	172	290	315	552	600	1023	—	
400	V 10	P <sub>N1</sub>	0,24	0,43	0,77	1,32	1,54	2,44	2,89	4,8	7,8	9,3	14,2	16,9	—	—	
		P <sub>N2</sub>	0,19	0,35	0,63	1,12	1,31	2,09	2,48	4,16	6,8	8,1	12,5	14,9	—	—	
		M <sub>N2</sub>	4,55	8,3	15,1	26,7	31,2	50	59	99	163	194	299	356	—	—	
		M <sub>2max</sub>	8,3	14,9	26,9	48,6	53	90	98	171	284	309	523	602	—	—	
35,5	1 400	V 40	P <sub>N1</sub>	0,19	0,34	0,6	1	1,19	1,86	2,21	3,64	5,7	6,8	10,9	12,9	19,8	35
			P <sub>N2</sub>	0,13	0,24	0,44	0,76	0,9	1,44	1,71	2,88	4,58	5,4	8,9	10,6	16,5	29,4
			M <sub>N2</sub>	3,6	6,6	11,9	20,7	24,6	39,2	46,7	79	125	149	243	289	449	802
			M <sub>2max</sub>	6,1	11,1	20,3	36,3	39,4	69	75	133	227	247	432	469	817	1445
	1 120	V 32	P <sub>N1</sub>	0,21	0,38	0,67	1,1	1,3	2,06	2,45	4,07	6,6	7,8	11,8	14,1	22,4	33,8
			P <sub>N2</sub>	0,15	0,28	0,49	0,83	0,99	1,61	1,91	3,24	5,3	6,3	9,8	11,6	18,8	29,4
			M <sub>N2</sub>	4,05	7,5	13,5	22,8	27,1	43,8	52	88	145	173	267	318	512	802
			M <sub>2max</sub>	6,9	12,8	22,8	40,4	43,9	77	83	146	254	276	464	504	881	1385
	900	V 25	P <sub>N1</sub>	0,23	0,42	0,76	1,24	1,48	2,35	2,8	4,51	6,3	7,5	11,7	13,9	22,8	40,4
			P <sub>N2</sub>	0,17	0,31	0,57	0,96	1,14	1,86	2,21	3,64	5,3	6,3	10	11,9	19,7	35,5
			M <sub>N2</sub>	4,44	8,1	15,1	25,4	30,2	49,3	59	97	141	168	265	315	524	943
			M <sub>2max</sub>	7,5	13,6	25	45,6	49,5	84	92	168	250	272	448	487	874	1612
710	V 20	P <sub>N1</sub>	0,24	0,44	0,78	1,09	1,29	2,04	2,43	4,14	6,8	8,1	12,5	14,9	24,9	43,1	
		P <sub>N2</sub>	0,18	0,32	0,59	0,88	1,05	1,68	2	3,47	5,8	6,9	10,7	12,8	21,7	37,8	
		M <sub>N2</sub>	4,82	8,7	16	23,8	28,3	45,2	54	93	155	185	289	344	583	1018	
		M <sub>2max</sub>	8	14,6	26,7	42,1	45,8	81	88	153	265	288	499	541	948	1712	
560	V 16	P <sub>N1</sub>	0,22	0,39	0,72	1,18	1,41	2,25	2,68	4,34	7	8,4	13,2	15,7	24,3	43,6	
		P <sub>N2</sub>	0,17	0,31	0,58	0,97	1,15	1,87	2,22	3,65	6	7,1	11,4	13,5	21,4	38,9	
		M <sub>N2</sub>	4,73	8,5	15,8	26,3	31,3	51	61	100	164	195	311	370	585	1061	
		M <sub>2max</sub>	7,7	14,1	25,8	45,8	49,8	88	96	163	277	301	548	595	965	1719	
450	V 13	P <sub>N1</sub>	0,21	0,38	0,69	1,19	1,41	2,22	2,65	4,46	7,2	8,6	13,8	16,4	25,9	—	
		P <sub>N2</sub>	0,17	0,31	0,56	0,98	1,16	1,86	2,21	3,78	6,3	7,4	12,1	14,4	22,8	—	
		M <sub>N2</sub>	4,68	8,4	15,4	27	32,1	51	61	104	173	205	334	397	630	—	
		M <sub>2max</sub>	8,2	15	27,4	48,6	53	91	99	178	300	325	574	624	1043	—	

Values in red state nominal thermal power  $P_{Tn}$  (ambient temperature 40 °C, continuous duty see ch. 3.2).

For  $n_1$  higher than 1 400 min<sup>-1</sup> or lower than 355 min<sup>-1</sup> see ch. 3.4 and page 32.

1) Values given for train of gears **IV** are nominal; see page 93 for effective transmission ratios.

2)  $M_{2max}$  represents maximum torque peak the gear reducer will withstand.

$n_{N2}$ $\min^{-1}$	$n_1$	Train of gears $i$	P [kW] M [daN m]	Gear reducer size																			
				32	40	50	63	64	80	81	100	125	126	160	161	200			250				
35,5	355	V 10	$P_{N1}$	0,22	0,39	0,71	1,22	1,4	2,24	2,65	2,1	4,41	7,2	8,5	6,2	13,1	9,6	15,6	9,6	—	—		
			$P_{N2}$	0,17	0,31	0,58	1,03	1,19	1,91	2,26	2,6	3,81	6,2	7,4	11,5	13,7	—	—	—	—	—	—	
			$M_{N2}$	4,69	8,4	15,6	27,7	31,9	51	61	102	168	200	311	370	—	—	—	—	—	—	—	—
			$M_{2max}$	8,4	15,1	27,3	49,9	54	93	101	174	293	318	542	623	—	—	—	—	—	—	—	—
31,5	1 250	V 40	$P_{N1}$	0,18	0,32	0,56	0,94	1,11	1,74	2,07	1,6	3,39	5,4	6,4	10,2	12,1	18,7	32,8	25	—	—		
			$P_{N2}$	0,12	0,22	0,4	0,7	0,83	1,33	1,59	2,67	4,26	5,1	8,3	9,9	15,4	15,4	27,5	27,5	—	—	—	
			$M_{2max}$	6,4	11,6	21	38,3	41,6	71	77	136	234	254	445	484	846	846	1501	1501	—	—	—	
	1 000	V 32	$P_{N1}$	0,2	0,35	0,62	1,02	1,22	1,91	2,28	1,6	3,79	6,1	7,3	11,1	13,2	21	15	31,6	31,6	—	—	
			$P_{N2}$	0,14	0,25	0,45	0,77	0,92	1,48	1,76	2,99	4,95	5,9	9,1	10,8	17,6	17,6	27,4	27,4	—	—	—	
			$M_{2max}$	7,1	12,9	23,2	42	45,6	79	85	152	261	283	493	536	929	929	1458	1458	—	—	—	
	800	V 25	$P_{N1}$	0,21	0,38	0,7	1,15	1,37	2,17	2,59	1,6	4,17	5,8	6,9	10,7	12,8	21,2	17	37,9	27	—	—	
			$P_{N2}$	0,15	0,28	0,52	0,88	1,04	1,7	2,02	3,34	4,88	5,8	9,2	10,9	18,3	18,3	33,1	33,1	—	—	—	
			$M_{2max}$	7,8	14,2	25,8	46,6	51	86	94	169	257	279	467	508	908	908	1668	1668	—	—	—	
	630	V 20	$P_{N1}$	0,22	0,4	0,72	0,99	1,18	1,87	2,23	1,8	3,83	6,3	7,5	11,6	13,8	23,1	16	40,3	24	—	—	
			$P_{N2}$	0,16	0,3	0,54	0,8	0,95	1,53	1,83	3,19	5,3	6,3	9,9	11,8	20	20	35,3	35,3	—	—	—	
			$M_{2max}$	8,3	15	27,5	43,9	47,7	83	90	156	272	295	519	564	983	983	1778	1778	—	—	—	
500	V 16	$P_{N1}$	0,2	0,36	0,66	1,09	1,29	2,07	2,46	1,8	4,01	6,5	7,8	12,3	14,6	22,4	16	40,3	25	—	—		
		$P_{N2}$	0,16	0,28	0,53	0,88	1,05	1,71	2,03	3,35	5,5	6,6	10,5	12,5	19,7	19,7	35,7	35,7	—	—	—		
		$M_{2max}$	7,9	14,3	26,5	47,2	51	91	99	171	284	308	561	610	984	984	1754	1754	—	—	—		
400	V 13	$P_{N1}$	0,2	0,35	0,63	1,09	1,3	2,05	2,44	1,8	4,12	6,6	7,9	12,8	15,2	23,9	15	—	—	—	—		
		$P_{N2}$	0,15	0,28	0,51	0,89	1,06	1,7	2,03	3,47	5,7	6,8	11,1	13,3	21	21	—	—	—	—	—		
		$M_{2max}$	8,4	15	27,8	49,9	54	95	103	181	309	335	588	638	1063	1063	—	—	—	—	—		
28	1 400	IV 50	$P_{N1}$	0,2	0,34	0,63	1	1,2	1,91	2,28	1,7	3,72	6,2	7,4	11,5	13,7	20,8	15	37,4	23	—		
			$P_{N2}$	0,14	0,26	0,49	0,79	0,94	1,54	1,83	3,03	5,1	6,1	9,6	11,5	17,8	17,8	32,5	32,5	—	—		
			$M_{2max}$	8,5	14,5	27,2	48,4	53	93	101	173	289	314	575	624	1002	1002	1788	1788	—	—	—	
	1 400	V 50	$P_{N1}$	0,14	0,26	0,47	0,77	0,92	1,44	1,72	2,69	4,49	5,3	8,3	9,9	16	16	28,1	28,1	—	—		
			$P_{N2}$	0,1	0,18	0,32	0,56	0,67	1,08	1,29	2,07	3,52	4,19	6,7	7,9	13	13	23,3	23,3	—	—	—	
			$M_{2max}$	5,2	10	19,6	34,7	37,7	65	71	123	212	231	409	445	786	786	1408	1408	—	—	—	
	1 120	V 40	$P_{N1}$	0,16	0,3	0,52	0,88	1,04	1,63	1,94	1,5	3,18	5,1	6	9,6	11,4	17,6	15	30,9	24	—	—	
			$P_{N2}$	0,11	0,2	0,37	0,65	0,77	1,24	1,47	2,48	3,98	4,74	7,7	9,2	14,5	14,5	25,8	25,8	—	—	—	
			$M_{2max}$	6,5	11,8	21,7	39,2	42,6	72	79	139	241	261	458	498	876	876	1557	1557	—	—	—	
	900	V 32	$P_{N1}$	0,18	0,33	0,58	0,96	1,14	1,79	2,13	1,5	3,55	5,8	6,9	10,4	12,4	19,8	14	29,8	29,8	—	—	
			$P_{N2}$	0,13	0,23	0,42	0,72	0,85	1,37	1,64	2,78	4,63	5,5	8,5	10,1	16,5	16,5	25,7	25,7	—	—	—	
			$M_{2max}$	7,3	13,6	23,6	43,6	47,3	81	88	157	268	291	507	551	977	977	1530	1530	—	—	—	
710	V 25	$P_{N1}$	0,2	0,35	0,64	1,06	1,27	2,01	2,39	1,5	3,85	6,4	7,8	11,7	14,6	19,7	16	35,4	25	—	—		
		$P_{N2}$	0,14	0,25	0,47	0,8	0,96	1,55	1,85	3,06	4,48	5,3	8,4	10	16,9	16,9	30,8	30,8	—	—	—		
		$M_{2max}$	8	14,4	26,5	47,4	51	88	96	175	263	286	486	528	941	941	1704	1704	—	—	—		
560	V 20	$P_{N1}$	0,21	0,37	0,67	0,91	1,08	1,72	2,05	3,54	5,8	6,9	10,7	12,8	21,4	15	37,7	23	—	—			
		$P_{N2}$	0,15	0,27	0,5	0,73	0,87	1,4	1,67	2,93	4,89	5,8	9,1	10,9	18,5	18,5	32,9	32,9	—	—	—		
		$M_{2max}$	8,5	15,6	28,2	44,6	48,5	86	93	158	279	303	539	586	1017	1017	1842	1842	—	—	—		
450	V 16	$P_{N1}$	0,19	0,34	0,62	1,01	1,2	1,92	2,28	1,7	3,73	6,1	7,3	11,5	13,7	20,8	15	37,4	23	—	—		
		$P_{N2}$	0,15	0,26	0,49	0,81	0,97	1,57	1,87	3,1	5,1	6,1	9,8	11,7	18,2	18,2	33,1	33,1	—	—	—		
		$M_{2max}$	8	14,5	27,2	48,4	53	93	101	173	289	314	575	624	1002	1002	1788	1788	—	—	—		
355	V 13	$P_{N1}$	0,18	0,32	0,58	1,01	1,2	1,89	2,25	1,7	3,79	6,1	7,2	11,8	14	22,1	14	—	—	—	—		
		$P_{N2}$	0,14	0,25	0,46	0,82	0,97	1,56	1,86	3,17	5,2	6,2	10,2	12,2	19,4	19,4	—	—	—	—	—		
		$M_{2max}$	8,5	15,7	28,2	51	56	96	104	183	317	345	597	649	1081	1081	—	—	—	—	—		
25	1 250	IV 50	$P_{N1}$	0,19	0,31	0,58	0,92	1,09	1,75	2,09	1,7	3,42	5,7	6,8	10,7	12,7	19,1	14	34,6	22	—		
			$P_{N2}$	0,13	0,24	0,44	0,72	0,86	1,4	1,67	2,77	4,68	5,6	8,9	10,6	16,3	16,3	29,9	29,9	—	—		
			$M_{N2}$	5,2	9,1	16,9	28,1	33,4	55	65	108	178	212	345	410	634	634	1161	1161	—	—	—	
			$M_{2max}$	8,7	14,9	27,6	49,1	53	95	103	178	298	323	588	638	1047	1047	1872	1872	—	—	—	

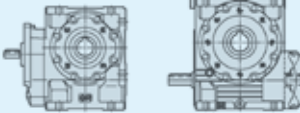
Values in red state nominal thermal power  $P_{Tn}$  (ambient temperature 40 °C, continuous duty see ch. 3.2).

For  $n_1$  higher than 1 400  $\min^{-1}$  or lower than 355  $\min^{-1}$  see ch. 3.4 and page 32.

1) Values given for train of gears **IV** are nominal; see page 93 for effective transmission ratios.

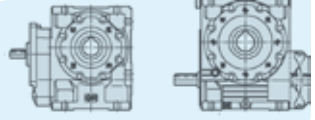
2)  $M_{2max}$  represents maximum torque peak the gear reducer will withstand.



$n_{N2}$ $\min^{-1}$	$n_1$	Train of gears $i$	P [kW] M [daN m]	Gear reducer size																		
				1)		2)		32	40	50	63	64	80	81	100	125	126	160	161	200	250	
18	1 120	IV 63	$P_{N1}$	0,14	0,28	0,5	0,66	0,76	1,22	1,45	2,56	4,3	5,1	8	9,5	6,9	15,9	11	28,7	17		
			$P_{N2}$	0,09	0,19	0,35	0,5	0,58	0,95	1,13	2,03	3,45	4,1	6,5	7,7	13,2	13,2	13,2	24	24	24	
			$M_{N2}$	5,2	10,2	18,9	27,3	31,6	52	61	110	183	218	352	419	713	713	713	1301	1301	1301	
				$M_{2max}$	8,6	16,5	30,5	47,1	53	93	101	176	306	332	599	651	1118	2032	2032	2032		
	1 120	V 63	$P_{N1}$	—	0,15	0,29	0,5	0,58	0,95	1,13	1,83	2,97	3,54	5,4	6,4	10,5	10,5	10,5	18,8	18,8	18,8	
			$P_{N2}$	—	0,09	0,18	0,34	0,39	0,66	0,79	1,32	2,21	2,63	4,12	4,9	8,2	8,2	8,2	15	15	15	
			$M_{N2}$	—	5	9,8	18,1	21,1	35,7	42,4	71	119	141	221	263	441	441	441	808	808	808	
				$M_{2max}$	—	7,6	15	29,2	32,7	60	67	118	218	236	407	442	789	1431	1431	1431		
	900	IV 50	$P_{N1}$	0,15	0,24	0,44	0,71	0,84	1,37	1,63	2,69	4,45	5,3	4,3	8,5	6,7	10,1	6,7	15	11	27,3	18
			$P_{N2}$	0,1	0,18	0,34	0,55	0,65	1,07	1,28	2,14	3,6	4,28	7	8,3	8,3	12,7	12,7	12,7	23,3	23,3	23,3
			$M_{N2}$	5,5	9,5	17,8	29,5	34,9	58	69	116	190	227	377	448	682	682	682	1256	1256	1256	
				$M_{2max}$	9	15,9	29,6	53	58	103	111	196	328	357	643	699	1144	2054	2054	2054		
900	V 50	$P_{N1}$	0,1	0,19	0,35	0,57	0,68	1,09	1,3	2,02	3,38	4,03	6,4	7,7	12,9	12,9	12,9	22,8	19	19	19	
		$P_{N2}$	0,06	0,12	0,23	0,4	0,47	0,78	0,93	1,49	2,56	3,05	5	5,9	10,2	10,2	10,2	18,5	18,5	18,5	18,5	
		$M_{N2}$	3,41	6,6	12,3	21,1	25,1	41,4	49,3	79	136	162	265	315	543	543	543	980	980	980	980	
			$M_{2max}$	5,2	10,2	20	38,6	42	74	80	136	242	263	469	509	915	1665	1665	1665	1665		
710	V 40	$P_{N1}$	0,12	0,21	0,38	0,64	0,76	1,21	1,44	2,36	3,83	4,56	7,3	8,7	7	13,4	11	23,8	17	17	17	
		$P_{N2}$	0,08	0,14	0,26	0,45	0,54	0,88	1,05	1,77	2,91	3,46	5,7	6,8	10,7	10,7	10,7	19,3	19,3	19,3	19,3	
		$M_{N2}$	4,13	7,5	13,8	24,4	29,1	47,5	57	95	157	186	308	366	578	578	578	1040	1040	1040	1040	
			$M_{2max}$	6,8	13,1	23,7	43,2	46,9	83	90	158	273	296	522	567	1004	1830	1830	1830	1830		
560	V 32	$P_{N1}$	0,13	0,23	0,42	0,68	0,81	1,31	1,56	2,62	4,29	5,1	4,2	7,8	6,6	9,2	6,6	14,8	10	21,3	18	
		$P_{N2}$	0,09	0,16	0,29	0,49	0,58	0,96	1,15	1,97	3,31	3,94	6,1	7,3	12	12	12	22,2	22,2	22,2	22,2	
		$M_{N2}$	4,89	8,7	16	26,7	31,7	53	63	108	181	215	335	399	653	653	653	1100	1100	1100	1100	
			$M_{2max}$	8	14,7	26,3	47,5	52	92	100	173	302	329	574	624	1100	1680	1680	1680	1680		
450	V 25	$P_{N1}$	0,14	0,25	0,46	0,77	0,91	1,46	1,74	2,84	3,89	4,62	7,2	8,5	14,2	12	26	19	19	19	19	
		$P_{N2}$	0,1	0,17	0,33	0,56	0,67	1,09	1,3	2,18	3,16	3,76	5,9	7,1	12	12	12	22,2	22,2	22,2	22,2	
		$M_{N2}$	5,2	9,3	17,4	29,7	35,3	58	69	116	168	200	315	375	634	634	634	1179	1179	1179	1179	
			$M_{2max}$	8,6	15,9	28,7	53	57	99	108	196	299	324	547	594	1039	1888	1888	1888	1888		
355	V 20	$P_{N1}$	0,15	0,27	0,49	0,65	0,75	1,2	1,43	2,53	4,17	4,96	7,9	9,4	6,9	15,7	11	28,3	17	17	17	
		$P_{N2}$	0,1	0,19	0,35	0,51	0,59	0,96	1,14	2,05	3,41	4,05	6,5	7,8	13,3	13,3	13,3	24,2	24,2	24,2	24,2	
		$M_{N2}$	5,5	10,2	18,9	27,3	31,6	52	61	110	183	218	352	419	713	713	713	1301	1301	1301	1301	
			$M_{2max}$	9	16,5	30,5	47,1	53	93	101	176	306	332	599	651	1118	2032	2032	2032	2032		
14	1 400	IV 100	$P_{N1}$	0,1	0,2	0,36	0,58	0,69	1,11	1,32	2,26	3,77	4,48	3,6	6,7	5,7	8	5,7	12,8	9	18,2	18,2
			$P_{N2}$	0,06	0,13	0,24	0,4	0,48	0,79	0,94	1,64	2,8	3,33	5,1	6,1	10	10	10	19,3	19,3	19,3	19,3
			$M_{N2}$	4,25	9,1	16,6	27,8	33	55	65	114	190	227	353	420	690	690	690	1030	1030	1030	1030
				$M_{2max}$	6,9	15	27,6	49,8	54	94	102	182	322	350	600	652	1138	1686	1686	1686	1686	
	1 120	IV 80	$P_{N1}$	0,11	0,21	0,4	0,64	0,76	1,24	1,47	2,44	3,37	4,01	6,1	7,2	12	10	22,1	16	16	16	16
			$P_{N2}$	0,07	0,14	0,27	0,45	0,54	0,89	1,06	1,81	2,66	3,17	4,85	5,8	9,8	9,8	9,8	18,3	18,3	18,3	18,3
			$M_{N2}$	5,1	9,5	18,1	30,6	36,4	61	72	123	177	211	328	390	663	663	663	1236	1236	1236	1236
				$M_{2max}$	8,1	16,2	29,7	55	59	102	111	202	302	333	577	626	1084	1997	1997	1997	1997	
	900	IV 63	$P_{N1}$	0,12	0,23	0,42	0,56	0,64	1,04	1,23	2,16	3,63	4,32	6,8	8,1	6,1	13,5	9,5	24,5	15	15	15
			$P_{N2}$	0,08	0,16	0,29	0,42	0,49	0,8	0,94	1,69	2,88	3,42	5,5	6,5	11,1	11,1	11,1	20,3	20,3	20,3	20,3
			$M_{N2}$	5,4	10,5	19,5	28,4	32,8	54	64	114	190	227	370	440	745	745	745	1368	1368	1368	1368
				$M_{2max}$	8,8	17,4	31,7	48,3	54	97	105	188	328	356	643	699	1202	2136	2136	2136	2136	
900	V 63	$P_{N1}$	—	0,13	0,24	0,43	0,49	0,82	0,97	1,57	2,56	3,04	4,68	5,6	9,2	9,2	9,2	16,5	16,5	16,5	16,5	
		$P_{N2}$	—	0,08	0,15	0,28	0,32	0,55	0,66	1,11	1,86	2,21	3,5	4,16	7,1	7,1	7,1	13	13	13	13	
		$M_{N2}$	—	5,1	9,9	19	21,6	37,1	44,1	74	124	148	234	278	474	474	474	870	870	870	870	
			$M_{2max}$	—	7,6	15	29,3	32,8	60	67	119	228	247	438	476	848	1568	1568	1568	1568		
710	IV 50	$P_{N1}$	0,12	0,2	0,37	0,6	0,68	1,12	1,33	2,22	3,68	4,38	7,1	5,9	8,5	5,9	12,4	10	22,7	16	16	
		$P_{N2}$	0,08	0,15	0,27	0,46	0,52	0,87	1,04	1,75	2,94	3,5	5,8	6,9	10,3	10,3	10,3	19,2	19,2	19,2	19,2	
		$M_{N2}$	5,7	9,8	18,4	31,2	35,6	60	71	120	198	235	395	470	707	707	707	1309	1309	1309	1309	
			$M_{2max}$	9,5	16,5	30,5	56	60	107	116	205	351	381	689	748	1171	2154	2154	2154	2154		
710	V 50	$P_{N1}$	0,09	0,16	0,3	0,48	0,57	0,92	1,09	1,72	2,87	3,41	5,6	6,6	11,1	11,1	11,1	19,9	16	16	16	
		$P_{N2}$	0,05	0,1	0,19	0,33	0,39	0,64	0,76	1,24	2,13	2,53	4,22	5	8,6	8,6	8,6	15,9	15,9	15,9	15,9	
		$M_{N2}$	3,53	6,9	12,9	22	26,1	43	51	83	143	170	284	338	581	581	581	1068	1068	1068	1068	
			$M_{2max}$	5,3	10,2	20,1	39,3	44	76	83	144	260	282	504	547	975	1789	1789	1789	1789		
560	V 40	$P_{N1}$	0,1	0,18	0,32	0,54	0,64	1,01	1,21	1,99	3,29	3,91	6,3	7,5	6	11,7	9,3	20,5	15	15	15	
		$P_{N2}$	0,06	0,11	0,21	0,37	0,45	0,72	0,86	1,46	2,45	2,91	4,87	5,8	9,2	9,2	9,2	16,5	16,5	16,5	16,5	
		$M_{N2}$	4,25	7,8	14,3	25,6	30,4	49,3	59	100	167	199	332	395	625	625	625	1125	1125	1125	1125	
			$M_{2max}$	6,9	13,4	24,8	45,4	49,3	85	93	162	285	310	560	608	1067	1898	1898	1898	1898		
450	V 32	$P_{N1}$	0,11	0,2	0,36	0,58	0,69	1,12	1,33	2,26	3,7	4,41	3,6	6,7	5,7	8	5,7	12,8	9	18,2	18,2	
		$P_{N2}$	0,07	0,13	0,24	0,41	0,49	0,81	0,96	1,67	2,8	3,34	5,2	6,2	10,2	10,2	10,2	19,3	19,3	19,3	19,3	
		$M_{N2}$	5,1	9,1	16,6	27,8	33	55	65	114	190	227	353	420	690	690	690	1030	1030	1030	1030	
			$M_{2max}$	8,1	15	27,6	49,8	54	94	102	182	322	350	600	652	1138	1686	1686	1686	1686		

Values in red state nominal thermal power  $P_{Tn}$  (ambient temperature 40 °C, continuous duty see ch. 3.2).



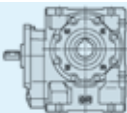

$n_{N2}$ $\frac{1}{\min^{-1}}$	$n_1$	Train of gears <i>i</i>	P [kW] M [daN m]	Gear reducer size																	
																					
				32	40	50	63	64	80	81	100	125	126	160	161	200	250				
14	355	V 25	$P_{N1}$	0,12	0,21	0,39	0,63	0,75	1,22	1,46	1,1	2,42	3,27	3,89	6	7,1	11,9	10	21,8	16	
			$P_{N2}$	0,08	0,14	0,27	0,45	0,54	0,9	1,07	1,82	2,63	3,13	4,88	5,8	9,9	9,9	18,4	18,4	18,4	18,4
			$M_{N2}$	5,4	9,5	18,1	30,6	36,4	61	72	123	177	211	328	390	663	663	1084	1084	1084	1084
			$M_{2max}$	8,8	16,2	29,7	55	59	102	111	202	302	333	577	626	1084	1084	1997	1997		
11,2	1 400	IV 125	$P_{N1}$	0,07	0,15	0,27	0,46	0,54	0,85	1,02	1,69	2,87	3,42	5,6	6,6	5,1	10,1	8	17,8	13	
			$P_{N2}$	0,04	0,09	0,17	0,31	0,36	0,58	0,7	1,19	2,05	2,44	4,11	4,89	7,7	7,7	13,7	13,7	13,7	13,7
			$M_{N2}$	3,62	8	14,7	26,5	31,6	51	60	103	174	208	356	423	663	663	1100	1100	1190	1190
			$M_{2max}$	5,3	13,4	25,9	47,5	52	90	97	171	301	327	583	634	1100	1100	2013	2013		
1 120	IV 100	$P_{N1}$	0,08	0,17	0,31	0,49	0,59	0,94	1,12	1,92	3,24	3,85	3,1	5,8	4,8	6,9	4,8	11	7,7	15,6	
		$P_{N2}$	0,05	0,11	0,2	0,33	0,39	0,66	0,78	1,37	2,36	2,8	4,29	5,1	8,4	8,4	12,6	12,6	12,6	12,6	
		$M_{N2}$	4,34	9,3	17,1	28,9	34,3	57	68	119	200	239	372	442	730	730	1092	1092	1092	1092	
			$M_{2max}$	6,9	15,5	28,2	52	56	99	107	191	339	368	636	691	1201	1201	1792	1792		
900	IV 80	$P_{N1}$	0,1	0,18	0,34	0,55	0,64	1,05	1,25	1,1	2,09	2,86	3,41	5,2	6,1	10,2	10,2	18,7	14		
		$P_{N2}$	0,06	0,12	0,23	0,38	0,44	0,74	0,89	1,52	2,23	2,65	4,08	4,86	8,2	8,2	15,3	15,3	15,3	15,3	
		$M_{N2}$	5,3	9,8	18,8	32	37,4	63	75	129	184	219	344	409	693	693	1149	1149	1288	1288	
			$M_{2max}$	8,4	17	31,1	58	63	109	118	215	309	347	617	670	1149	1149	2094	2094		
710	IV 63	$P_{N1}$	0,1	0,19	0,35	0,47	0,52	0,88	1,01	1,79	2,98	3,55	5,7	6,7	5,4	11,2	8,5	20,4	13		
		$P_{N2}$	0,06	0,13	0,24	0,35	0,39	0,67	0,77	1,38	2,34	2,78	4,5	5,4	9,1	9,1	16,7	16,7	16,7	16,7	
		$M_{N2}$	5,6	10,8	20,1	30	33,5	57	66	118	196	233	379	458	746	746	1286	1286	1423	1423	
			$M_{2max}$	9,3	18,3	33,4	49,4	55	101	111	196	349	379	687	746	1286	1286	2292	2292		
710	V 63	$P_{N1}$	—	0,1	0,2	0,36	0,41	0,69	0,81	1,34	2,16	2,57	3,99	4,74	7,9	7,9	14,1	14,1	14,1		
		$P_{N2}$	—	0,06	0,12	0,23	0,26	0,46	0,54	0,92	1,53	2,16	2,57	3,99	4,74	7,9	7,9	14,1	14,1	14,1	
		$M_{N2}$	—	5,1	10,1	19,7	22,1	38,8	45,5	78	130	155	247	294	505	505	929	929	929	929	
			$M_{2max}$	—	7,7	15,1	29,5	33	60	68	119	233	261	458	497	877	877	1625	1625		
560	IV 50	$P_{N1}$	0,1	0,16	0,3	0,5	0,55	0,94	1,1	1,82	3,02	3,6	5,9	7	5,4	10,2	10,2	18,6	14		
		$P_{N2}$	0,07	0,12	0,22	0,38	0,42	0,72	0,85	1,42	2,39	2,84	4,74	5,6	8,5	8,5	15,6	15,6	15,6	15,6	
		$M_{N2}$	5,8	10	18,8	32,9	36,2	63	73	124	203	242	410	488	732	732	1350	1350	1350	1350	
			$M_{2max}$	9,9	16,9	32	59	62	113	122	217	366	397	735	798	1197	1197	2204	2204		
560	V 50	$P_{N1}$	0,07	0,13	0,25	0,4	0,48	0,76	0,91	1,46	2,44	2,9	4,73	5,6	9,5	9,5	16,9	14	14		
		$P_{N2}$	0,04	0,08	0,16	0,27	0,32	0,52	0,62	1,03	1,77	2,1	3,52	4,19	7,3	7,3	13,3	13,3	13,3	13,3	
		$M_{N2}$	3,62	7	13,5	22,8	27,1	44,4	53	88	151	179	300	357	621	621	1135	1135	1135	1135	
			$M_{2max}$	5,3	10,3	20,2	39,5	44,2	80	87	149	277	300	526	571	1007	1007	1850	1850		
450	V 40	$P_{N1}$	0,08	0,15	0,27	0,46	0,55	0,85	1,02	1,69	2,82	3,36	5,6	6,6	5,1	10,1	8	17,8	13		
		$P_{N2}$	0,05	0,09	0,17	0,31	0,37	0,6	0,71	1,22	2,05	2,44	4,19	4,99	7,8	7,8	14	14	14	14	
		$M_{N2}$	4,34	8	14,7	26,5	31,6	51	60	103	174	208	356	423	663	663	1100	1100	1190	1190	
			$M_{2max}$	6,9	13,4	25,9	47,5	52	90	97	171	301	327	583	634	1100	1100	2013	2013		
355	V 32	$P_{N1}$	0,1	0,17	0,3	0,49	0,58	0,93	1,11	1,9	3,14	3,73	5,7	6,8	4,8	10,9	7,7	15,4	15,4		
		$P_{N2}$	0,06	0,11	0,2	0,34	0,4	0,66	0,79	1,38	2,33	2,77	4,32	5,1	8,5	8,5	12,7	12,7	12,7	12,7	
		$M_{N2}$	5,3	9,3	17,1	28,9	34,3	57	68	119	200	239	372	442	730	730	1092	1092	1092	1092	
			$M_{2max}$	8,4	15,5	28,2	52	56	99	107	191	339	368	636	691	1201	1201	1792	1792		
9	1 400	IV 160	$P_{N1}$	—	0,11	0,22	0,35	0,41	0,64	0,77	1,24	2,13	2,54	4,03	4,8	8,2	8,2	14,5	12		
			$P_{N2}$	—	0,07	0,13	0,22	0,26	0,42	0,5	0,84	1,48	1,76	2,88	3,43	6	6	11	11	11	11
			$M_{N2}$	—	7,2	13,9	23,8	28,1	45,8	54	91	157	187	312	371	606	606	1062	1062	1189	1189
			$M_{2max}$	—	10,3	20,2	39,6	44,3	81	91	156	284	308	558	606	1062	1062	1907	1907		
1 120	IV 125	$P_{N1}$	0,06	0,12	0,23	0,38	0,45	0,72	0,85	1,43	2,45	2,91	4,79	5,7	4,4	8,8	6,9	15,4	11		
		$P_{N2}$	0,03	0,08	0,14	0,25	0,3	0,48	0,57	0,99	1,71	2,04	3,46	4,12	6,5	6,5	11,7	11,7	11,7	11,7	
		$M_{N2}$	3,69	8	15,2	27	32,1	52	62	107	182	217	374	446	703	703	1270	1270	1270	1270	
			$M_{2max}$	5,3	13,4	26,3	48,5	53	94	102	178	316	343	614	667	1157	1157	2072	2072		
900	IV 100	$P_{N1}$	0,07	0,14	0,26	0,42	0,49	0,81	0,96	1,64	2,74	3,27	2,8	4,95	5,9	4,3	9,5	6,8	13,3		
		$P_{N2}$	0,04	0,09	0,17	0,28	0,33	0,55	0,65	1,15	1,96	2,34	3,63	4,32	7,1	7,1	10,6	10,6	10,6	10,6	
		$M_{N2}$	4,37	9,6	17,8	30,1	35,3	59	71	124	208	248	391	466	767	767	1141	1141	1141	1141	
			$M_{2max}$	6,9	16,3	29,7	54	59	105	114	204	361	392	680	739	1258	1258	1830	1830		
710	IV 80	$P_{N1}$	0,08	0,15	0,28	0,47	0,52	0,87	1,03	1,74	2,4	2,82	4,38	5,1	8,4	8,4	15,4	12			
		$P_{N2}$	0,05	0,1	0,18	0,32	0,36	0,6	0,72	1,24	1,85	2,17	3,42	3,99	6,7	6,7	12,4	12,4	12,4	12,4	
		$M_{N2}$	5,5	10,2	19,4	33,8	38	65	77	133	194	227	365	426	713	713	1326	1326	1326	1326	
			$M_{2max}$	8,8	17,8	32,7	61	65	113	123	229	316	354	634	710	1227	1227	2240	2240		
560	IV 63	$P_{N1}$	0,08	0,16	0,29	0,39	0,43	0,74	0,84	1,45	2,46	2,9	4,67	5,6	9,3	7,6	16,6	12			
		$P_{N2}$	0,05	0,1	0,19	0,29	0,32	0,55	0,63	1,11	1,9	2,24	3,68	4,37	7,4	7,4	13,5	13,5	13,5	13,5	
		$M_{N2}$	5,7	11,1	20,5	31,5	34,3	60	68	120	202	239	398	473	803	803	1457	1457	1457	1457	
			$M_{2max}$	9,5	19,1	35	50	56	104	116	203	364	395	716	778	1370	1370	2448	2448		
560	V 63	$P_{N1}$	—	0,09	0,16	0,3	0,34	0,59	0,67	1,13	1,85	2,2	3,4	4,02	6,8	6,8	12,1	12,1			
		$P_{N2}$	—	0,05	0,1	0,19	0,21	0,38	0,43	0,75	1,28	1,52	2,43	2,87	4,98	4,98	9,2	9,2	9,2	9,2	
		$M_{N2}$	—	5,2	10,4	20,2	22,6	40,6	46,4	81	137	163	261	309	535	535	984	984	984	984	
			$M_{2max}$	—	7,7	15,2	29,6	33,1	61	68	120	234	262	489	531	904	904	1720	1720		

Values in red state nominal thermal power  $P_{N1}$  (ambient temperature 40 °C, continuous duty see ch. 3.2).

For  $n_1$ , higher than 1 400 min<sup>-1</sup> or lower than 355 min<sup>-1</sup> see ch. 3.4 and page 32.

1) Values given for train of gears **IV** are nominal; see page 93 for effective transmission ratios.

2)  $M_{2max}$  represents maximum torque peak the gear reducer will withstand.

$n_{N2}$	$n_1$	Train of gears $i$	P [kW] M [daN m]	Gear reducer size															
				32	40	50	63	64	80	81	100	125	126	160	161			200	250
9	450	IV 50	P <sub>N1</sub>	0,08	0,13	0,25	0,42	0,46	0,81	0,91	1,54	2,6	2,99	4,97	5,9	4,6	8,6	15,5	
			P <sub>N2</sub>	0,05	0,1	0,18	0,31	0,34	0,61	0,69	1,19	2,03	2,34	3,95	4,67	7,1	7,1	12,9	
			M <sub>N2</sub>	6	10,2	19,2	34	36,8	66	75	128	215	248	425	503	762	1392		
				M <sub>2max</sub>	10,4	17,3	33,5	61	62	119	127	224	388	418	766	832	1226	2281	
		450	V 50	P <sub>N1</sub>	0,06	0,11	0,21	0,35	0,41	0,65	0,77	1,24	2,09	2,49	4,03	4,8	8,2	14,5	
	P <sub>N2</sub>			0,03	0,07	0,13	0,22	0,26	0,43	0,51	0,86	1,48	1,76	2,94	3,49	6,2	11,2		
	M <sub>N2</sub>			3,69	7,2	13,9	23,8	28,1	45,8	54	91	157	187	312	371	653	1189		
				M <sub>2max</sub>	5,3	10,3	20,2	39,6	44,3	81	91	156	284	308	558	606	1062	1907	
		355	V 40	P <sub>N1</sub>	0,07	0,12	0,22	0,38	0,45	0,71	0,84	1,41	2,37	2,82	4,72	5,6	4,4	8,6	15,2
P <sub>N2</sub>	0,04			0,07	0,14	0,25	0,3	0,49	0,58	1	1,69	2,02	3,48	4,14	6,5	11,8			
M <sub>N2</sub>	4,37			8	15,2	27	32,1	52	62	107	182	217	374	446	703	1270			
			M <sub>2max</sub>	6,9	13,4	26,3	48,5	53	94	102	178	316	343	614	667	1157	2072		
7,1	1 400	IV 200	P <sub>N1</sub>	—	0,07	0,14	0,25	0,28	0,5	0,56	1,34	2,18	2,59	4,04	4,8	3,9	7,8	10,8	
			P <sub>N2</sub>	—	0,04	0,08	0,15	0,17	0,31	0,35	0,92	1,53	1,82	2,91	3,47	5,8	8,5		
			M <sub>N2</sub>	—	5,4	10,6	20,6	23	42,2	47,3	128	213	253	406	483	802	1181		
				M <sub>2max</sub>	—	7,7	15,2	29,6	33,1	61	68	212	376	409	725	787	1344	1865	
		1 120	IV 160	P <sub>N1</sub>	—	0,1	0,18	0,29	0,34	0,55	0,65	1,05	1,82	2,16	3,42	4,07	7	12,3	
	P <sub>N2</sub>			—	0,06	0,11	0,18	0,21	0,35	0,42	0,7	1,24	1,47	2,39	2,84	5	9,1		
	M <sub>N2</sub>			—	7,3	14,3	24,7	28,9	47,6	57	95	165	195	323	385	677	1236		
				M <sub>2max</sub>	—	10,3	20,3	39,6	44,4	81	91	160	297	322	572	621	1089	2007	
		900	IV 125	P <sub>N1</sub>	0,05	0,11	0,19	0,33	0,38	0,61	0,72	1,2	2,07	2,46	4,06	4,83	3,9	7,6	13,4
	P <sub>N2</sub>			0,03	0,06	0,12	0,21	0,24	0,4	0,47	0,82	1,42	1,69	2,88	3,43	5,5	9,9		
	M <sub>N2</sub>			3,77	8,3	15,4	28,5	32,4	54	64	110	188	223	388	462	748	1340		
				M <sub>2max</sub>	5,3	13,7	26,9	51	55	97	106	186	337	366	655	712	1210	2220	
		710	IV 100	P <sub>N1</sub>	0,05	0,12	0,22	0,36	0,41	0,66	0,79	1,36	2,25	2,68	4,12	4,9	3,9	7,9	11
	P <sub>N2</sub>			0,03	0,07	0,14	0,23	0,26	0,44	0,53	0,93	1,58	1,88	2,97	3,54	5,9	8,6		
	M <sub>N2</sub>			4,49	9,8	18,4	31,7	36,1	61	73	128	213	253	406	483	802	1181		
				M <sub>2max</sub>	7,1	16,7	30,6	57	61	109	119	212	376	409	725	787	1344	1865	
		560	IV 80	P <sub>N1</sub>	0,06	0,12	0,23	0,39	0,43	0,72	0,84	1,45	1,99	2,29	3,64	4,19	6,9	12,6	
	P <sub>N2</sub>			0,04	0,08	0,15	0,26	0,29	0,49	0,58	1,02	1,51	1,74	2,81	3,23	5,4	10,1		
M <sub>N2</sub>	5,6			10,4	19,8	34,9	38,8	66	78	138	201	232	380	437	734	1362			
			M <sub>2max</sub>	9	18,3	34,2	63	66	119	129	238	322	361	647	724	1263	2386		
	450	IV 63	P <sub>N1</sub>	0,07	0,13	0,24	0,33	0,35	0,63	0,71	1,22	2,11	2,41	3,95	4,66	7,8	13,8		
P <sub>N2</sub>			0,04	0,09	0,16	0,24	0,26	0,47	0,53	0,92	1,61	1,84	3,07	3,62	6,1	11,1			
M <sub>N2</sub>			5,8	11,5	21	32,5	34,6	63	71	124	214	244	414	488	826	1491			
			M <sub>2max</sub>	9,8	19,6	36,6	52	58	106	119	208	385	413	746	810	1425	2605		
	450	V 63	P <sub>N1</sub>	—	0,07	0,14	0,25	0,28	0,5	0,56	0,95	1,59	1,89	2,95	3,48	5,8	10,3		
P <sub>N2</sub>			—	0,04	0,08	0,15	0,17	0,32	0,35	0,62	1,07	1,28	2,05	2,42	4,15	7,7			
M <sub>N2</sub>			—	5,4	10,6	20,6	23	42,2	47,3	83	144	171	275	323	555	1030			
			M <sub>2max</sub>	—	7,7	15,2	29,6	33,1	61	68	120	234	262	491	548	952	1769		
	355	IV 50	P <sub>N1</sub>	0,07	0,11	0,2	0,35	0,37	0,66	0,75	1,25	2,14	2,45	4,1	4,79	7,1	12,9		
P <sub>N2</sub>			0,04	0,08	0,15	0,26	0,27	0,5	0,56	0,96	1,66	1,89	3,22	3,77	5,8	10,6			
M <sub>N2</sub>			6,1	10,4	19,6	35,6	37,4	68	77	131	222	254	440	515	786	1448			
			M <sub>2max</sub>	10,6	17,7	34,3	64	64	123	130	235	400	423	809	875	1250	2329		
	355	V 50	P <sub>N1</sub>	0,05	0,09	0,18	0,29	0,34	0,54	0,64	1,04	1,77	2,09	3,37	4,02	6,9	12,2		
P <sub>N2</sub>			0,03	0,05	0,11	0,18	0,21	0,35	0,42	0,7	1,23	1,45	2,4	2,86	5	9,2			
M <sub>N2</sub>			3,77	7,3	14,3	24,7	28,9	47,6	57	95	165	195	323	385	677	1236			
			M <sub>2max</sub>	5,3	10,3	20,3	39,6	44,4	81	91	160	297	322	572	621	1089	2007		
5,6	400	IV 250	P <sub>N1</sub>	—	—	—	—	—	—	—	0,98	1,67	1,98	3,28	3,91	6,2	11		
			P <sub>N2</sub>	—	—	—	—	—	—	—	—	0,65	1,12	1,33	2,29	2,72	4,45	8	
			M <sub>N2</sub>	—	—	—	—	—	—	—	—	114	195	230	398	474	775	1400	
				M <sub>2max</sub>	—	—	—	—	—	—	193	351	381	696	756	1289	2319		
		1 120	IV 200	P <sub>N1</sub>	—	0,06	0,12	0,21	0,24	0,42	0,47	1,12	1,85	2,17	3,41	4,06	6,5	5,4	9,1
	P <sub>N2</sub>			—	0,03	0,06	0,12	0,14	0,25	0,28	0,76	1,27	1,49	2,42	2,88	4,74	7,1	12,28	
	M <sub>N2</sub>			—	5,5	10,8	21	23,5	43,1	48,2	132	220	259	421	501	826	1430	1948	
				M <sub>2max</sub>	—	7,7	15,2	29,6	33,1	61	68	220	391	425	754	819	1430	1948	
		900	IV 160	P <sub>N1</sub>	—	0,08	0,15	0,25	0,29	0,47	0,55	0,89	1,59	1,82	2,94	3,44	5,9	10,5	
P <sub>N2</sub>	—			0,05	0,09	0,15	0,17	0,29	0,34	0,58	1,06	1,22	2,01	2,35	4,19	7,6			
M <sub>N2</sub>	—			7,5	14,7	26,1	29,5	49,5	58	97	175	201	339	396	706	1284			
			M <sub>2max</sub>	—	10,5	20,7	40,4	45,3	83	93	163	315	343	610	662	1162	2098		
	710	IV 125	P <sub>N1</sub>	0,04	0,09	0,16	0,27	0,31	0,52	0,59	1	1,73	2,04	3,35	3,99	6,4	11,2		
P <sub>N2</sub>			0,02	0,05	0,09	0,17	0,19	0,33	0,38	0,66	1,16	1,37	2,33	2,78	4,54	8,2			
M <sub>N2</sub>			3,85	8,5	15,8	29,4	32,7	57	65	114	195	230	398	474	775	1400			
			M <sub>2max</sub>	5,4	14	27,4	53	56	103	111	193	351	381	696	756	1289	2319		

Values in red state nominal thermal power  $P_{Tn}$  (ambient temperature 40 °C, continuous duty see ch. 3.2).  
For  $n_1$  higher than 1 400 min<sup>-1</sup> or lower than 355 min<sup>-1</sup> see ch. 3.4 and page 32.

1) Values given for train of gears IV are nominal; see page 93 for effective transmission ratios.

2)  $M_{2max}$  represents maximum torque peak the gear reducer will withstand.

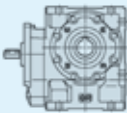
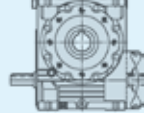
$n_{N2}$	$n_1$	Train of gears $i$	P [kW] M [daN m]	Gear reducer size														
				32	40	50	63	64	80	81	100	125	126	160	161	200	250	
5,6	560	IV 100	$P_{N1}$	0,05	0,1	0,18	0,3	0,33	0,56	0,65	1,13	1,88	2,21	3,43	4,08	6,6	5,4	9,1
			$P_{N2}$	0,03	0,06	0,11	0,19	0,21	0,37	0,43	0,76	1,29	1,52	2,43	2,89	4,77	7,1	12,28
			$M_{N2}$ $M_{2max}$	4,6 7,2	10 17,1	18,7 31,9	32,6 59	36,6 61	64 115	74 123	132 220	220 391	259 425	421 754	501 819	826 1430	1430	1948
	450	IV 80	$P_{N1}$	0,05	0,1	0,19	0,33	0,36	0,62	0,7	1,21	1,71	1,92	3,07	3,54	5,9	10,5	
			$P_{N2}$	0,03	0,07	0,12	0,22	0,23	0,41	0,47	0,84	1,28	1,44	2,34	2,7	4,56	8,3	14,02
			$M_{N2}$ $M_{2max}$	5,6 9,2	10,8 18,7	20,2 35,1	36,7 66	39,4 67	70 123	80 134	141 250	212 329	238 369	395 661	454 740	768 1290	1402	2484
	355	IV 63	$P_{N1}$	0,05	0,11	0,19	0,27	0,28	0,52	0,57	0,98	1,74	1,97	3,33	3,8	6,4	11,3	9,1
			$P_{N2}$	0,03	0,07	0,13	0,2	0,2	0,38	0,42	0,74	1,31	1,49	2,56	2,92	4,97	9	15,31
			$M_{N2}$ $M_{2max}$	6 10,2	11,6 20,1	21,3 37,5	33,4 53	34,7 59	65 108	73 121	126 212	220 397	249 417	437 786	499 848	849 1481	1531	2709
	355	V 63	$P_{N1}$	—	0,06	0,11	0,21	0,23	0,41	0,46	0,78	1,36	1,57	2,54	2,92	4,81	8,7	
			$P_{N2}$	—	0,03	0,06	0,12	0,14	0,25	0,28	0,5	0,9	1,04	1,73	1,99	3,38	6,3	
			$M_{N2}$ $M_{2max}$	—	5,5 7,7	10,8 15,2	21 29,6	23,5 33,1	43,1 61	48,2 68	85 120	153 234	176 262	293 491	337 550	572 959	1067	1856
4,5	1 400	IV 315	$P_{N1}$	—	—	—	—	—	—	0,73	1,29	1,49	2,46	2,81	4,81	8,5		
			$P_{N2}$	—	—	—	—	—	—	—	0,46	0,84	0,97	1,65	1,89	3,32	6,1	
			$M_{N2}$ $M_{2max}$	—	—	—	—	—	—	—	100 166	182 326	211 356	359 647	411 703	724 1235	1322	2235
	1 120	IV 250	$P_{N1}$	—	—	—	—	—	—	—	0,83	1,42	1,65	2,73	3,25	5,3	9,2	
			$P_{N2}$	—	—	—	—	—	—	—	0,54	0,93	1,08	1,86	2,22	3,68	6,6	
			$M_{N2}$ $M_{2max}$	—	—	—	—	—	—	—	117 203	202 364	235 396	405 724	482 786	802 1368	1440	2467
	900	IV 200	$P_{N1}$	—	0,05	0,1	0,18	0,2	0,35	0,39	0,94	1,57	1,81	2,89	3,43	5,5	7,7	
			$P_{N2}$	—	0,03	0,05	0,1	0,11	0,21	0,23	0,62	1,06	1,23	2,01	2,38	3,92	5,9	
			$M_{N2}$ $M_{2max}$	—	5,6 7,8	11 15,5	21,4 30,1	23,9 33,7	43,9 62	49,1 69	135 230	230 413	264 446	435 784	516 851	851 1487	1274	1984
	710	IV 160	$P_{N1}$	—	0,07	0,13	0,21	0,24	0,4	0,45	0,74	1,33	1,54	2,51	2,87	4,9	8,7	
			$P_{N2}$	—	0,04	0,07	0,13	0,14	0,24	0,28	0,47	0,87	1	1,68	1,93	3,39	6,2	
			$M_{N2}$ $M_{2max}$	—	7,6 10,7	14,9 21,1	26,9 41,1	29,8 46,1	52 84	59 94	100 166	182 326	211 356	359 647	411 703	724 1235	1322	2235
	560	IV 125	$P_{N1}$	0,03	0,07	0,13	0,23	0,25	0,43	0,49	0,83	1,44	1,68	2,75	3,27	5,3	9,3	
			$P_{N2}$	0,02	0,04	0,08	0,14	0,15	0,27	0,31	0,54	0,95	1,1	1,87	2,23	3,7	6,7	
			$M_{N2}$ $M_{2max}$	3,92 5,5	8,7 14,2	16,2 27,9	30,8 54	33,5 57	59 106	67 114	117 203	202 364	235 396	405 724	482 786	802 1368	1440	2467
	450	IV 100	$P_{N1}$	0,04	0,08	0,15	0,25	0,27	0,47	0,54	0,95	1,6	1,84	2,91	3,45	5,5	7,7	
			$P_{N2}$	0,02	0,05	0,09	0,16	0,17	0,3	0,35	0,62	1,08	1,25	2,02	2,39	3,95	5,9	
			$M_{N2}$ $M_{2max}$	4,79 7,3	10,2 17,5	19 32,7	33,6 61	37 62	66 118	75 126	135 230	230 413	264 446	435 784	516 851	851 1487	1274	1984
	355	IV 80	$P_{N1}$	0,04	0,08	0,15	0,27	0,29	0,51	0,58	1	1,41	1,55	2,58	2,94	4,83	8,7	
			$P_{N2}$	0,03	0,05	0,1	0,18	0,19	0,34	0,38	0,68	1,04	1,14	1,94	2,21	3,7	6,8	
			$M_{N2}$ $M_{2max}$	5,7 9,6	11,1 19,5	20,5 35,9	37,8 68	40,1 68	72 127	82 137	145 257	218 335	240 375	415 672	473 753	790 1313	1444	2563
	3,55	1 120	IV 315	$P_{N1}$	—	—	—	—	—	—	—	0,61	1,09	1,25	2,09	2,41	4	7,2
				$P_{N2}$	—	—	—	—	—	—	—	0,38	0,7	0,8	1,37	1,58	2,71	5
				$M_{N2}$ $M_{2max}$	—	—	—	—	—	—	—	103 169	189 331	216 367	373 672	429 730	738 1283	1366
900		IV 250	$P_{N1}$	—	—	—	—	—	—	—	0,7	1,22	1,38	2,3	2,72	4,42	7,8	
			$P_{N2}$	—	—	—	—	—	—	—	0,44	0,79	0,89	1,54	1,82	3,03	5,5	
			$M_{N2}$ $M_{2max}$	—	—	—	—	—	—	—	120 209	213 383	241 410	417 751	494 815	820 1420	1495	2615
710		IV 200	$P_{N1}$	—	0,04	0,08	0,15	0,16	0,29	0,32	0,77	1,3	1,49	2,44	2,81	4,55	6,3	
			$P_{N2}$	—	0,02	0,04	0,08	0,09	0,17	0,19	0,5	0,86	0,99	1,67	1,92	3,19	4,8	
			$M_{N2}$ $M_{2max}$	—	5,7 8	11,2 15,7	21,7 30,6	24,3 34,3	44,6 63	50 70	136 236	237 426	270 450	459 826	528 893	876 1544	1318	2015
560		IV 160	$P_{N1}$	—	0,05	0,1	0,18	0,19	0,33	0,37	0,61	1,11	1,27	2,11	2,42	4,02	7,2	
			$P_{N2}$	—	0,03	0,06	0,1	0,11	0,2	0,22	0,38	0,71	0,81	1,38	1,59	2,73	5	
			$M_{N2}$ $M_{2max}$	—	7,7 10,9	15,2 21,4	28,2 41,8	30,5 46,8	54 86	61 96	103 169	189 331	216 367	373 672	429 730	738 1283	1366	2372
450	IV 125	$P_{N1}$	0,03	0,06	0,11	0,19	0,21	0,37	0,41	0,7	1,25	1,41	2,31	2,74	4,44	7,9		
		$P_{N2}$	0,01	0,03	0,06	0,12	0,12	0,23	0,26	0,45	0,8	0,91	1,55	1,83	3,04	5,5		
		$M_{N2}$ $M_{2max}$	3,98 5,6	9 14,5	16,6 28,4	31,7 55	33,8 57	62 111	69 118	120 209	213 383	241 410	417 751	494 815	820 1420	1495	2615	
355	IV 100	$P_{N1}$	0,03	0,07	0,12	0,2	0,22	0,39	0,44	0,77	1,33	1,52	2,46	2,83	4,58	6,4		
		$P_{N2}$	0,02	0,04	0,07	0,13	0,14	0,25	0,28	0,5	0,88	1,01	1,68	1,93	3,21	4,82		
		$M_{N2}$ $M_{2max}$	4,98 7,4	10,4 18,2	19,3 34	34,6 62	37,4 62	68 122	77 129	136 236	237 426	270 450	459 826	528 893	876 1544	1318	2015	

Values in red state nominal thermal power  $P_{tn}$  (ambient temperature 40 °C, continuous duty see ch. 3.2).

For  $n_1$  higher than 1 400 min<sup>-1</sup> or lower than 355 min<sup>-1</sup> see ch. 3.4 and page 32.

1) Values given for train of gears **IV** are nominal; see page 93 for effective transmission ratios.

2)  $M_{2max}$  represents maximum torque peak the gear reducer will withstand.

$n_{N2}$ min <sup>-1</sup>	$n_1$	Train of gears i	P [kW] M [daN m]	Gear reducer size														
				32	40	50	63	64	80	81	100	125	126	160	161			200
2,8	900	IV 315	P <sub>N1</sub>	—	—	—	—	—	—	—	—	0,51	0,94	1,05	1,77	2,03	3,37	6
			P <sub>N2</sub>	—	—	—	—	—	—	—	—	—	—	0,31	0,59	0,66	1,14	1,31
	M <sub>N2</sub>	—	—	—	—	—	—	—	—	—	—	105	198	222	386	443	755	1402
	M <sub>2max</sub>	—	—	—	—	—	—	—	—	—	—	172	337	377	696	754	1331	2463
	710	IV 250	P <sub>N1</sub>	—	—	—	—	—	—	—	—	0,57	1,01	1,14	1,94	2,22	3,62	6,5
560	IV 200	P <sub>N1</sub>	—	0,03	0,07	0,12	0,13	0,24	0,27	0,62	1,09	1,19	2,02	2,29	3,71	5,2	—	
450	IV 160	P <sub>N2</sub>	—	0,02	0,03	0,06	0,07	0,13	0,15	0,4	0,71	0,78	1,36	1,54	2,56	3,85	—	
		M <sub>N2</sub>	—	5,7	11,3	22,1	24,7	45,3	51	139	248	271	472	536	891	1343	—	
	M <sub>2max</sub>	—	8,1	16	31,1	34,8	64	72	242	446	460	840	911	1622	2044	—		
	355	IV 125	P <sub>N1</sub>	0,02	0,05	0,09	0,16	0,16	0,3	0,34	0,57	1,03	1,16	1,95	2,23	3,64	6,5	—
			P <sub>N2</sub>	0,01	0,03	0,05	0,1	0,1	0,19	0,21	0,36	0,65	0,73	1,28	1,47	2,45	4,51	—
		M <sub>N2</sub>	4,05	9,4	17,3	32,6	33,8	64	71	122	219	246	438	501	838	1540	—	
		M <sub>2max</sub>	5,7	14,7	28,9	56	57	114	119	218	395	412	778	850	1473	2713	—	
2,24	710	IV 315	P <sub>N1</sub>	—	—	—	—	—	—	—	—	0,43	0,78	0,85	1,5	1,7	2,77	5
			P <sub>N2</sub>	—	—	—	—	—	—	—	—	—	—	0,26	0,48	0,52	0,94	1,07
	M <sub>N2</sub>	—	—	—	—	—	—	—	—	—	—	110	203	223	405	460	772	1444
	M <sub>2max</sub>	—	—	—	—	—	—	—	—	—	—	174	342	378	718	774	1397	2554
	560	IV 250	P <sub>N1</sub>	—	—	—	—	—	—	—	—	0,46	0,85	0,92	1,61	1,82	2,96	5,3
450	IV 200	P <sub>N2</sub>	—	0,03	0,05	0,1	0,11	0,2	0,22	0,5	0,91	0,98	1,72	1,94	3,15	4,27	—	
		M <sub>N2</sub>	—	0,01	0,03	0,05	0,06	0,11	0,12	0,32	0,59	0,63	1,14	1,28	2,13	3,15	—	
	M <sub>2max</sub>	—	5,8	11,5	22,4	25,1	46,1	52	138	254	272	494	556	923	1364	—		
	355	IV 160	P <sub>N1</sub>	—	0,04	0,07	0,12	0,13	0,23	0,26	0,43	0,79	0,87	1,51	1,71	2,78	5	—
			P <sub>N2</sub>	—	0,02	0,04	0,07	0,07	0,13	0,15	0,26	0,48	0,53	0,95	1,08	1,81	3,38	—
		M <sub>N2</sub>	—	8	15,7	29,5	31,1	58	64	110	203	223	405	460	772	1444	—	
		M <sub>2max</sub>	—	11,3	22,1	43,2	48,4	89	99	174	342	378	718	774	1397	2554	—	
1,8	560	IV 315	P <sub>N1</sub>	—	—	—	—	—	—	—	—	0,35	0,64	0,68	1,24	1,39	2,29	4,13
			P <sub>N2</sub>	—	—	—	—	—	—	—	—	—	—	0,21	0,39	0,41	0,76	0,86
	M <sub>N2</sub>	—	—	—	—	—	—	—	—	—	—	112	209	224	416	469	795	1484
	M <sub>2max</sub>	—	—	—	—	—	—	—	—	—	—	177	347	381	728	774	1426	2671
	450	IV 250	P <sub>N1</sub>	—	—	—	—	—	—	—	—	0,38	0,71	0,75	1,35	1,52	2,49	4,5
355	IV 200	P <sub>N2</sub>	—	—	—	—	—	—	—	—	—	0,24	0,44	0,46	0,86	0,96	1,61	3
		M <sub>N2</sub>	—	—	—	—	—	—	—	—	—	128	236	249	465	522	874	1628
	M <sub>2max</sub>	—	—	—	—	—	—	—	—	—	—	226	424	424	800	850	1573	2931
	355	IV 200	P <sub>N1</sub>	—	0,02	0,04	0,08	0,09	0,16	0,18	0,42	0,75	0,79	1,39	1,56	2,62	3,44	—
			P <sub>N2</sub>	—	0,01	0,02	0,04	0,05	0,09	0,1	0,26	0,48	0,5	0,91	1,02	1,75	2,52	—
		M <sub>N2</sub>	—	5,9	11,7	22,8	25,5	46,7	52	144	263	275	500	560	961	1384	—	
		M <sub>2max</sub>	—	8,4	16,5	32,1	35,9	66	74	252	468	467	850	921	1730	2102	—	
1,4	450	IV 315	P <sub>N1</sub>	—	—	—	—	—	—	—	—	0,29	0,54	0,56	1,03	1,15	1,95	3,5
			P <sub>N2</sub>	—	—	—	—	—	—	—	—	—	—	0,17	0,32	0,34	0,63	0,7
	M <sub>N2</sub>	—	—	—	—	—	—	—	—	—	—	116	216	226	428	477	827	1532
	M <sub>2max</sub>	—	—	—	—	—	—	—	—	—	—	179	352	384	738	774	1446	2757
355	IV 250	P <sub>N1</sub>	—	—	—	—	—	—	—	—	0,32	0,58	0,6	1,11	1,24	2,03	3,71	
		P <sub>N2</sub>	—	—	—	—	—	—	—	—	0,19	0,36	0,37	0,7	0,78	1,3	2,43	
		M <sub>N2</sub>	—	—	—	—	—	—	—	—	131	243	251	481	534	894	1666	
		M <sub>2max</sub>	—	—	—	—	—	—	—	—	226	428	427	810	850	1597	2995	
1,12	355	IV 315	P <sub>N1</sub>	—	—	—	—	—	—	—	—	0,24	0,45	0,45	0,85	0,94	1,59	2,88
			P <sub>N2</sub>	—	—	—	—	—	—	—	—	—	—	0,14	0,26	0,27	0,51	0,57
		M <sub>N2</sub>	—	—	—	—	—	—	—	—	120	225	229	442	489	845	1579	
		M <sub>2max</sub>	—	—	—	—	—	—	—	—	181	356	385	748	774	1465	2769	

## Summary of transmission ratios $i$ and torques valid for $n_1 \leq 90 \text{ min}^{-1}$

$M_{N2}$  and  $M_{2max}$  are the nominal torque and the peak torque, respectively, valid for  $n_1 \leq 90 \text{ min}^{-1}$ .

### R V

$i$	$M$ [daN m]	Gear reducer size													
		32	40	50	63	64	80	81	100	125	126	160	161	200	250
10	$M_{N2}$	6,1	11,1	20,4	37,5	38,7	72	80	132	229	252	434	493	–	–
	$M_{2max}$	11	20	36,7	68	68	129	136	238	411	428	781	888	–	–
13	$M_{N2}$	6,1	11,2	20,7	37,3	38,5	73	81	139	243	265	468	530	886	–
	$M_{2max}$	11	20,1	37,3	67	67	131	137	250	410	451	842	902	1 537	–
16	$M_{N2}$	5,9	10,7	19,9	36,6	37,5	70	78	134	233	255	464	526	824	1 495
	$M_{2max}$	9,2	18	35,4	66	66	126	132	241	420	434	835	894	1 274	2 374
20	$M_{N2}$	6,4 <sup>1)</sup>	11,6 <sup>1)</sup>	21,3 <sup>1)</sup>	34,9	35,4	67	74	127	231	252	450	510	863	1 563
	$M_{2max}$	11,5	20,9	38,4	53	60	110	123	216	416	428	810	866	1 554	2 813
25	$M_{N2}$	6,2	11,3	20,8	39,4 <sup>1)</sup>	40,6 <sup>1)</sup>	74 <sup>1)</sup>	82 <sup>1)</sup>	146 <sup>1)</sup>	225	242	427	482	817	1 508
	$M_{2max}$	10,9	20,1	37,4	71	71	132	140	263	341	381	683	766	1 335	2 605
32	$M_{N2}$	5,9	10,6	19,6	36,1	37,8	70	78	139	248 <sup>1)</sup>	271 <sup>1)</sup>	472 <sup>1)</sup>	536 <sup>1)</sup>	891 <sup>1)</sup>	1 343
	$M_{2max}$	9,9	18,6	34,9	65	65	125	131	242	446	460	840	911	1 622	2 044
40	$M_{N2}$	5,4	9,8	17,9	33,5	34,4	65	72	124	229	248	451	510	853	1 562 <sup>1)</sup>
	$M_{2max}$	7,7	14,9	29,3	57	58	117	119	223	413	422	790	850	1 536	2 812
50	$M_{N2}$	4,17	8,1	15,9	30	31,2	60	66	112	209	224	416	469	795	1 484
	$M_{2max}$	5,9	11,4	22,4	43,8	49	90	100	177	347	381	728	774	1 426	2 671
63	$M_{N2}$	–	6	11,8	23	25,6	47,3	53	93	182	201	379	426	707	1 353
	$M_{2max}$	–	8,5	16,7	32,5	36,4	67	75	131	257	288	540	604	1 054	2 056

### R IV

$i_N$	Gear reducer size				$M$ [daN m]	Gear reducer size											
	32	40, 50, 125, 126	63, 64, 80, 81, 100	160, 161, 200, 250		32	40	50	63, 64	80	81	100	125, 126	160	161	200	250
50	51,8 2,59	49,9 3,12 <sup>3)</sup>	50,9 3,18	50,8 3,17	$M_{N2}$	7,3	13	24,1	44,3	78	84	144	272	487	540	824	1 495
					$M_{2max}$	11,5	19,5	37,7	70	133	138	250	455	880	953	1383	2 406
63	64,8	62,4	63,6	63,5	$M_{N2}$	7,1	13,7	25	41	76	86	151	277	487	540	925	1 718
					$M_{2max}$	10,9	21,4	40,2	65	119	128	233	453	880	910	1 597	2 863
80	82,9	78	79,5	79,3	$M_{N2}$	6,7	13,3	24,4	47,5	80	90	160	260	487	540	957	1 743
					$M_{2max}$	10	20,2	38	73	133	141	268	384	735	824	1 436	2 802
100	104	99,8	102	102	$M_{N2}$	5,7	12,6	23,2	43,3	78	88	155	295 <sup>1)</sup>	500	560	1 000	1 438
					$M_{2max}$	8,1	18,6	34,9	66	128	131	252	468	850	921	1 736	2 227
125	130	125	127	127	$M_{N2}$	4,38	11,3	21,2	40,6	75	85	146	273	487	540	975	1 800 <sup>1)</sup>
					$M_{2max}$	6,2	15,9	31,2	60	119	124	226	428	820	850	1 597	3 034
160	–	156	159	159	$M_{N2}$	–	8,6	16,9	33	68	76	133	252	487	540	925	1 748
					$M_{2max}$	–	12,1	23,8	49	95	107	188	385	774	774	1 470	2 769
200	–	197	200	–	$M_{N2}$	–	6,3	12,5	26,4	50	56	–	–	–	–	–	–
					$M_{2max}$	–	8,9	17,7	38,5	71	79	–	–	–	–	–	–
200	–	203 6,36	204 6,38	204 6,38	$M_{N2}$	–	–	–	–	–	–	156	300	500	560	1 000	1 483
					$M_{2max}$	–	–	–	–	–	–	252	468	850	921	1 736	2 291
250	–	254	255	255	$M_{N2}$	–	–	–	–	–	–	150	289	487	540	975	1 900
					$M_{2max}$	–	–	–	–	–	–	226	428	820	850	1 597	3 134
315	–	318	319	319	$M_{N2}$	–	–	–	–	–	–	137	268	487	540	975	1 850
					$M_{2max}$	–	–	–	–	–	–	193	385	774	774	1 470	2 769

1) For these transmission ratios (which will transmit higher torques at lower speeds) torque increases further as  $n_1$  decreases, as stated in table A ch. 3.9; for sizes 32 and 40 consult us.  
 2) Gear ratio of input cylindrical gear pair.  
 3) For sizes 125 and 126 it is equal to 3,13.

Notes of page 42

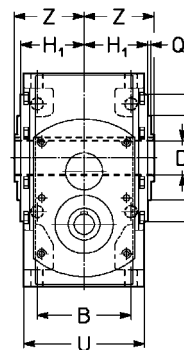
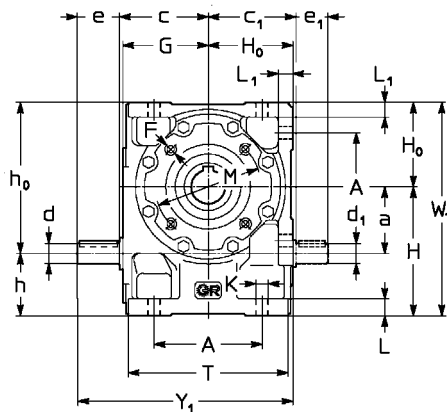
Values in red state nominal thermal power  $P_{Tn}$  (ambient temperature 40 °C, continuous duty see ch. 3.2).

For  $n_1$  higher than 1 400  $\text{min}^{-1}$  or lower than 355  $\text{min}^{-1}$  see ch. 3.4 and page 32.

1) Values given for train of gears IV are nominal; see page 32 for effective transmission ratios.

2)  $M_{2max}$  represents maximum torque peak the gear reducer will withstand.

# Designs, dimensions, mounting positions & oil quantity 3.6

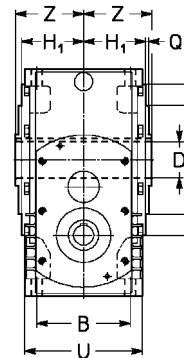
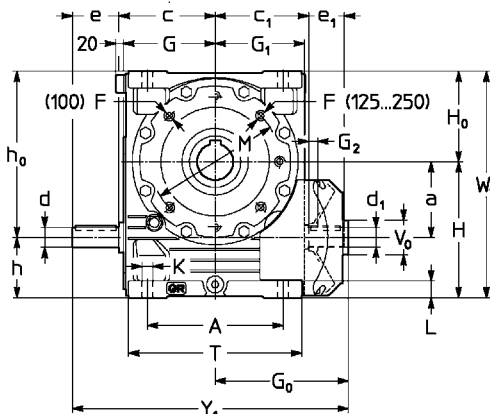
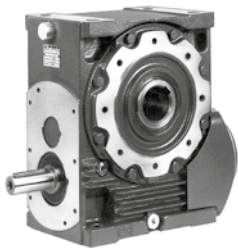


## RV 32 ... 81

### Design

standard	UO3A <sup>1) 5)</sup>
double extension worm	UO3D <sup>1) 5)</sup>
reduced worm shaft end	UO3B <sup>1) 5)</sup>
double extension worm with reduced shaft end	UO3C <sup>1) 5)</sup>

UTC 685



## RV 100 ... 250

### Design

standard	UO2A <sup>5) 5)</sup>
reduced worm shaft end	UO2B <sup>1) 5)</sup>

UTC 686

Size	a	A	B	D Ø H7	c	d Ø	e	c	d	e	Y <sub>1</sub> Ø	d <sub>1</sub>	e <sub>1</sub>	F	G <sub>0</sub>	G <sub>1</sub>	G <sub>2</sub>	H h11	H <sub>0</sub> h11	H <sub>1</sub> h12	h h11	h <sub>0</sub> h11	K Ø	L	L <sub>1</sub>	M Ø h6	N Ø	P Ø	Q	T	U	V <sub>0</sub> Ø	W <sub>1</sub>	Y <sub>1</sub>	Z	Mass kg
32	32	61	52	19	51	14	25	50	10	14	112	11	20	M5 <sup>6)</sup>	—	—	—	71	48	34,5	39	80	7	10	8,5	75	55 <sup>7)</sup>	90	3	91	66	—	119	124	39	3
40	40	70	62	24	59,5 <sup>4)</sup>	16	30	59,5	12	14	130	14	25	M6 <sup>6)</sup>	—	—	—	82	56	41,5	42	96	9,5	12	10	85	68 <sup>7)</sup>	105	3	106	80	—	138	146	46	5
50	50	86	75	28	70,5	19	30	70,5	12	14	152	16	30	M6 <sup>6)</sup>	—	—	—	100	67	49	50	117	9,5	13	12	100	85 <sup>7)</sup>	120	3	126	95	—	167	168	53	9
63, 64	63	102	90	32	83	19	40	85	17	17	182	19	30	M8	—	—	—	125	80	58,5	62	143	11,5	16	14	100	80	120	3	151	114	—	205	203	63	14
80 81	80	132	106	38 40	103	24	50	105	17	17	222	24	36	M10	—	—	—	150	100	69,5	70	180	14	20	17	130	110	160	3,5	189	135	—	250	253	75	24
100	100	180	131	48	130	28	60	130	20	21	331	28	42	M12	180	122	11	180	125	84,5	80	225	16	23	—	165	130	200	3,5	236	165	45	305	370	90	43
125, 126	125	225	155	60	155	32	80	155	25	26	402	32	58	M12 <sup>8)</sup>	221	148	15	225	150	99,5	100	275	18	28	—	215	180	250	4	287	194	50	375	456	106	74
160 161	160	272	183	70 75	187	38	80	181	35	36	472	38	58	M14 <sup>8)</sup>	255	178	15	280	180	118,5	120	340	22	33	—	265	230	300	4	345	232	60	460	522	125	130
200	200	342	214	90	232 <sup>4)</sup>	48	110	226	35	36	586	48	82	M16 <sup>8)</sup>	324	222	20	335	225	137,5	135	425	27	40	—	300	250	350	5	431	270	80	560	666	150	233
250	250	425	250	110	292 <sup>4)</sup>	60	105	281	40	46	706	55	82	M20 <sup>8) 3)</sup>	379	277	20	410	280	163	160	530	33	50	—	400	350	450	5	537	320	80	690	776	180	382

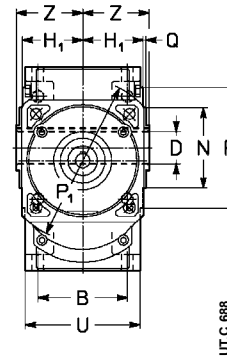
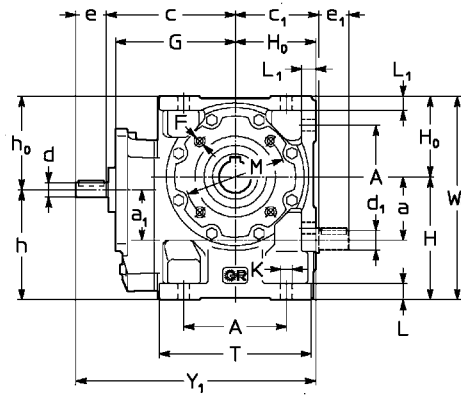
- 1) Only for  $i \geq 16$ .
- 2) Working length of thread 2 · F.
- 3) Holes turned through 22° 30' with respect to the drawing.
- 4) Size 40: c<sub>1</sub> = 57,5; size 200: c<sub>1</sub> = 235; size 250: c<sub>1</sub> = 287.
- 5) Prearranged design for double extension worm shaft (see ch. 2).
- 6) Holes turned through 45° with respect to the drawing.
- 7) Tolerance t8.

## Mounting positions - direction of rotation - and oil quantities [l]

	B3	B6	B7	B8	V5	V6	Size	B3	B6, B7	B8	V5, V6
							32	0,16	0,2	0,16	0,16
							40	0,26	0,35	0,26	0,26
							50	0,4	0,6	0,4	0,4
							63, 64	0,8	1,15	0,8	0,8
							80, 81	1,3	2,2	1,7	1,3
							100	1,9	5,4	4,2	3
							125, 126	3,4	10	8,2	5,7
							160, 161	5,6	18	15	10
							200	9,5	33	30	20
							250	17	57	51	34

1) Sizes 200 and 250 in mounting position B7, with  $n_1 > 710 \text{ min}^{-1}$  carry a price addition.

# Designs, dimensions, mounting positions & oil quantity 3.6



**R IV 32 ... 81**

**Design**

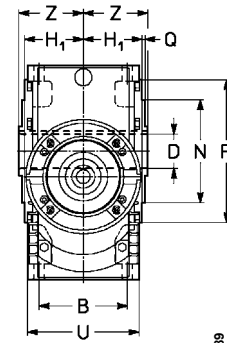
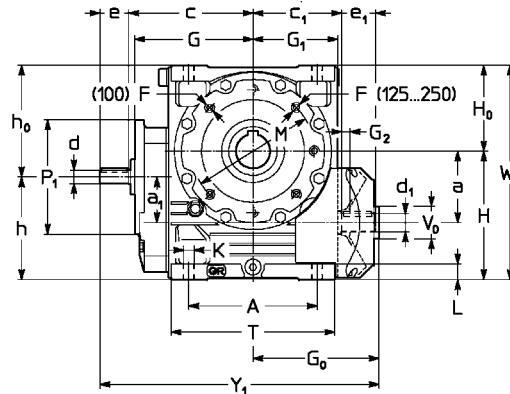
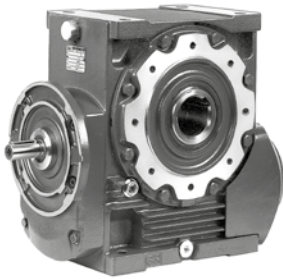
standard

**UO3A<sup>1)</sup>**

worm extension

**UO3D<sup>1)</sup>**

UT.C 688



**R IV 100 ... 250**

**Design**

standard

**UO2A<sup>1)</sup>**

UT.C 688

Size	a	a <sub>1</sub>	A	B	c	c <sub>1</sub>	D ∅ H7	d ∅	e	d <sub>1</sub> ∅	e <sub>1</sub>	F	G	G <sub>0</sub>	G <sub>1</sub>	G <sub>2</sub>	H	H <sub>0</sub>	H <sub>1</sub>	h	h <sub>0</sub>	K ∅	L	L <sub>1</sub>	M ∅	N ∅ h6	P ∅	P <sub>1</sub> ∅	Q	T	U	V <sub>0</sub> ∅ max	W <sub>1</sub>	Y <sub>1</sub>	Z	Mass kg
32	32	32	61	52	81	51	19	11	20	11	20	M5 <sup>2)</sup>	76	—	—	—	71	48	34,5	71	48	7	10	8,5	75	55 <sup>3)</sup>	90	140 <sup>6)</sup>	3	91	66	—	124	149	39	5
40	40	40	70	62	96	57,5	24	11	23	14	25	M6 <sup>4)</sup>	87	—	—	—	82	56	41,5	82	56	9,5	12	10	85	68 <sup>5)</sup>	105	140 <sup>6)</sup>	3	106	80	—	138	175	46	7
50	50	40	86	75	107	70,5	28	11	23	16	30	M6 <sup>4)</sup>	98	—	—	—	100	67	49	90	77	9,5	13	12	100	85 <sup>5)</sup>	120	140 <sup>6)</sup>	3	126	95	—	167	197	53	11
63, 64	63	50	102	90	127	83	32	14	30	19	30	M8	118	—	—	—	125	80	58,5	112	93	11,5	16	14	100	80	120	160 <sup>6)</sup>	3	151	114	—	205	237	63	17
80, 81	80	50	132	106	147	103	38	14	30	24	36	M10	138	—	—	—	150	100	69,5	120	130	14	20	17	130	110	160	160 <sup>6)</sup>	3,5	189	135	—	250	277	75	27
100	100	63	180	131	181	130	48	19*	40*	28	42	M12	170	180	122	11	180	125	84,5	143	162	16	23	—	165	130	200	200	3,5	236	165	45	305	401	90	48
125, 126	125	80	225	155	216	155	60	24*	50*	32	58	M12 <sup>6)</sup>	205	221	148	15	225	150	99,5	180	195	18	28	—	215	180	250	200	4	287	194	50	375	487	106	82
160, 161	160	100	272	183	258	187	70	28*	60*	38	58	M14 <sup>6)</sup>	247	255	178	15	280	180	118,5	220	240	22	33	—	265	230	300	250	4	345	232	60	460	573	125	146
200	200	100	342	214	303	235	90	28*	60*	48	82	M16 <sup>6)</sup>	292	324	222	20	335	225	137,5	235	325	27	40	—	300	250	350	250	5	431	270	80	560	687	150	249
250	250	125	425	250	373	287	110	32	80	55	82	M20 <sup>6,3)</sup>	360	379	277	20	410	280	163	285	405	33	50	—	400	350	450	300	5	537	320	80	690	832	180	408

1) Prearranged design for worm shaft extension (see ch. 2).

2) Working length of thread 2 · F.

3) Holes turned through 22° 30' with respect to the drawing.

4) Holes turned through 45° with respect to the drawing.

5) Tolerance t8.

6) Square flange: for dimensions see ch. 15.

\* When  $i_{w} \geq 200$  the shaft end will be:

size 100: d = 16, e = 30;

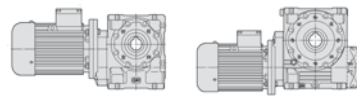
sizes 125, 126: d = 19, e = 40;

sizes 160 ... 200: d = 24, e = 50.

## Mounting positions - direction of rotation - and oil quantities [l]

	B3	B6	B7	B8	V5	V6	Size	B3	B6, B7	B8	V5, V6
							32	0,2	0,25	0,2	0,2
							40	0,32	0,4	0,32	0,32
							50	0,5	0,7	0,5	0,5
							63, 64	1	1,3	1	1
							80, 81	1,5	2,5	2	1,5
							100	2,1	6,3	4,5	3,3
							125, 126	3,8	11,6	8,8	6,3
							160, 161	6,5	20,8	16,5	11,2
							200	10,4	38	31,5	21,2
							250	18,3	67	53	35,7

1) Sizes 100 ... 250 in mounting position **B6** carry a price addition.

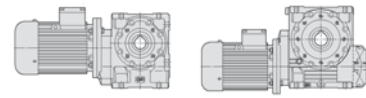


$P_1$ kW 1)	$n_2$ min <sup>-1</sup>	$P_2$ kW	$M_2$ daN m	$f_s$	Riduttore - Motore Gear reducer - Motor 2)	$i$	
0,09	2,06	0,05	23,3	0,8	MR 2IV 50 - 11 x 140 63 A 6	437	
	2,58	0,05	19,7	1	MR 2IV 50 - 11 x 140 63 A 6	349	
	3,3	0,06	15,9	0,71	MR 2IV 40 - 11 x 140 63 A 6	273	
	3,3	0,06	16,2	1,32	MR 2IV 50 - 11 x 140 63 A 6	273	
	4,12	0,06	13,3	0,9	MR 2IV 40 - 11 x 140 63 A 6	218	
	4,12	0,06	13,5	1,6	MR 2IV 50 - 11 x 140 63 A 6	218	
	4,08	0,05	11,3	1	MR IV 50 - 11 x 140 63 A 6	221	
	5,07	0,06	10,6	1	MR 2IV 40 - 11 x 140 63 A 6	178	
	5,14	0,05	9,4	0,8	MR IV 40 - 11 x 140 63 A 6	175	
	5,07	0,06	10,8	1,9	MR 2IV 50 - 11 x 140 63 A 6	178	
	5,14	0,05	9,6	1,5	MR IV 50 - 11 x 140 63 A 6	175	
	6,33	0,06	8,8	1,32	MR 2IV 40 - 11 x 140 63 A 6	142	
	6,43	0,05	8	1,06	MR IV 40 - 11 x 140 63 A 6	140	
	6,43	0,06	8,2	1,9	MR IV 50 - 11 x 140 63 A 6	140	
	7,92	0,07	7,9	1,32	MR 2IV 40 - 11 x 140 63 A 6	114	
	8,04	0,06	6,8	1,4	MR IV 40 - 11 x 140 63 A 6	112	
	8,04	0,06	6,9	2,65	MR IV 50 - 11 x 140 63 A 6	112	
	8,68	0,05	6	0,71	MR IV 32 - 11 x 140 63 A 6	104	
	10,3	0,06	5,5	1,8	MR IV 40 - 11 x 140 63 A 6	87,5	
	10,9	0,06	5,1	1,06	MR IV 32 - 11 x 140 63 A 6	82,9	
	12,9	0,06	4,59	2,36	MR IV 40 - 11 x 140 63 A 6	70	
	13,9	0,06	4,16	1,32	MR IV 32 - 11 x 140 63 A 6	64,8	
	14,3	0,05	3,62	1,4	MR V 40 - 11 x 140 63 A 6	63	
	17,4	0,06	3,45	1,6	MR IV 32 - 11 x 140 63 A 6	51,8	
	18	0,06	3	1,12	MR V 32 - 11 x 140 63 A 6	50	
	18	0,06	3,08	2,12	MR V 40 - 11 x 140 63 A 6	50	
	21,7	0,07	3,02	1,7	MR IV 32 - 11 x 140 63 A 6	41,5	
	22,5	0,06	2,53	1,6	MR V 32 - 11 x 140 63 A 6	40	
	28,1	0,06	2,12	2	MR V 32 - 11 x 140 63 A 6	32	
	36	0,07	1,73	2,5	MR V 32 - 11 x 140 63 A 6	25	
	0,12	2,58	0,07	26,3	0,75	MR 2IV 50 - 11 x 140 63 B 6	349
		3,21	0,07	20,6	0,8	MR 2IV 50 - 11 x 140 63 A 4	437
		3,3	0,07	21,6	1	MR 2IV 50 - 11 x 140 63 B 6	273
4,01		0,07	17,4	1,12	MR 2IV 50 - 11 x 140 63 A 4	349	
4,12		0,08	18	1,25	MR 2IV 50 - 11 x 140 63 B 6	218	
4,08		0,06	15	0,75	MR IV 50 - 11 x 140 63 B 6	221	
5,13		0,08	14	0,8	MR 2IV 40 - 11 x 140 63 A 4	273	
5,13		0,08	14,3	1,4	MR 2IV 50 - 11 x 140 63 A 4	273	
5,14		0,07	12,8	1,18	MR IV 50 - 11 x 140 63 B 6	175	
6,41		0,08	11,7	1	MR 2IV 40 - 11 x 140 63 A 4	218	
6,43		0,07	10,7	0,8	MR IV 40 - 11 x 140 63 B 6	140	
6,41		0,08	11,8	1,8	MR 2IV 50 - 11 x 140 63 A 4	218	
6,35		0,07	10,2	1,06	MR IV 50 - 11 x 140 63 A 4	221	
6,43		0,07	10,9	1,4	MR IV 50 - 11 x 140 63 B 6	140	
7,88		0,08	9,3	1,12	MR 2IV 40 - 11 x 140 63 A 4	178	
8		0,07	8,4	0,85	MR IV 40 - 11 x 140 63 A 4	175	
8,04		0,08	9	1,06	MR IV 40 - 11 x 140 63 B 6	112	
7,88		0,08	9,5	2,12	MR 2IV 50 - 11 x 140 63 A 4	178	
8		0,07	8,7	1,6	MR IV 50 - 11 x 140 63 A 4	175	
8,04		0,08	9,2	2	MR IV 50 - 11 x 140 63 B 6	112	
9,85		0,08	7,7	1,4	MR 2IV 40 - 11 x 140 63 A 4	142	
10		0,07	7,1	1,12	MR IV 40 - 11 x 140 63 A 4	140	
10,3		0,08	7,4	1,32	MR IV 40 - 11 x 140 63 B 6	87,5	
10		0,08	7,3	2	MR IV 50 - 11 x 140 63 A 4	140	
10,9		0,08	6,7	0,8	MR IV 32 - 11 x 140 63 B 6	82,9	
12,3		0,09	6,9	1,4	MR 2IV 40 - 11 x 140 63 A 4	114	
12,5		0,08	6	1,5	MR IV 40 - 11 x 140 63 A 4	112	
12,9		0,08	6,1	1,7	MR IV 40 - 11 x 140 63 B 6	70	
13,5		0,08	5,4	0,8	MR IV 32 - 11 x 140 63 A 4	104	
13,9		0,08	5,5	0,95	MR IV 32 - 11 x 140 63 B 6	64,8	
14,3		0,07	4,83	1,06	MR V 40 - 11 x 140 63 B 6	63	
14,3		0,07	4,99	2	MR V 50 - 11 x 140 63 B 6	63	
16,9		0,08	4,51	1,06	MR IV 32 - 11 x 140 63 A 4	82,9	
16	0,08	4,94	1,9	MR IV 40 - 11 x 140 63 A 4	87,5		
17,4	0,08	4,6	1,18	MR IV 32 - 11 x 140 63 B 6	51,8		

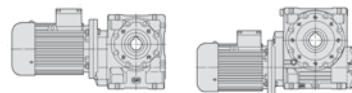
$P_1$ kW 1)	$n_2$ min <sup>-1</sup>	$P_2$ kW	$M_2$ daN m	$f_s$	Riduttore - Motore Gear reducer - Motor 2)	$i$
0,12	18	0,08	4	0,85	MR V 32 - 11 x 140 63 B 6	50
	18	0,08	4,1	1,6	MR V 40 - 11 x 140 63 B 6	50
	20	0,09	4,08	2,5	MR IV 40 - 11 x 140 63 A 4	70
	21,6	0,08	3,7	1,32	MR IV 32 - 11 x 140 63 A 4	64,8
	22,5	0,08	3,37	1,18	MR V 32 - 11 x 140 63 B 6	40
	22,2	0,08	3,29	1,5	MR V 40 - 11 x 140 63 A 4	63
	22,5	0,08	3,44	2,12	MR V 40 - 11 x 140 63 B 6	40
	27	0,09	3,06	1,7	MR IV 32 - 11 x 140 63 A 4	51,8
	28	0,08	2,7	1,18	MR V 32 - 11 x 140 63 A 4	50
	28,1	0,08	2,83	1,5	MR V 32 - 11 x 140 63 B 6	32
	28	0,08	2,77	2,12	MR V 40 - 11 x 140 63 A 4	50
	33,8	0,09	2,65	1,8	MR IV 32 - 11 x 140 63 A 4	41,5
	35	0,08	2,27	1,6	MR V 32 - 11 x 140 63 A 4	40
	36	0,09	2,31	1,9	MR V 32 - 11 x 140 63 B 6	25
	35	0,08	2,32	2,8	MR V 40 - 11 x 140 63 A 4	40
	43,8	0,09	1,89	2	MR V 32 - 11 x 140 63 A 4	32
	45	0,09	1,91	2,36	MR V 32 - 11 x 140 63 B 6	20
	56	0,09	1,54	2,5	MR V 32 - 11 x 140 63 A 4	25
	70	0,09	1,27	3,15	MR V 32 - 11 x 140 63 A 4	20
	87,5	0,1	1,08	3,35	MR V 32 - 11 x 140 63 A 4	16
108	0,1	0,89	4	MR V 32 - 11 x 140 63 A 4	13	
140	0,1	0,7	4,75	MR V 32 - 11 x 140 63 A 4	10	
0,18	1,49	0,1	65	0,95	MR 2IV 80 - 14 x 160 71 A 6	605
	1,49	0,1	65	1,06	MR 2IV 81 - 14 x 160 71 A 6	605
	1,86	0,11	55	1,25	MR 2IV 80 - 14 x 160 71 A 6	484
	1,86	0,11	55	1,32	MR 2IV 81 - 14 x 160 71 A 6	484
	2,33	0,11	44,7	0,85	MR 2IV 63 - 14 x 160 71 A 6	387
	2,33	0,11	45,8	1,6	MR 2IV 80 - 14 x 160 71 A 6	387
	2,33	0,11	45,8	1,7	MR 2IV 81 - 14 x 160 71 A 6	387
	2,98	0,11	36,6	1,12	MR 2IV 63 - 14 x 160 71 A 6	302
	2,98	0,12	37,6	2	MR 2IV 80 - 14 x 160 71 A 6	302
	2,98	0,12	37,6	2,24	MR 2IV 81 - 14 x 160 71 A 6	302
	3,56	0,12	31,1	1,25	MR 2IV 63 - 14 x 160 71 A 6	253
	3,56	0,12	31,7	2,36	MR 2IV 80 - 14 x 160 71 A 6	253
	3,56	0,12	31,7	2,65	MR 2IV 81 - 14 x 160 71 A 6	253
	4,01	0,11	26	0,75	MR 2IV 50 - 11 x 140 63 B 4	349
	3,76	0,1	25,8	0,85	MR IV 63 - 14 x 160 71 A 6	239
	3,76	0,1	25,8	0,95	MR IV 64 - 14 x 160 71 A 6	239
	3,76	0,11	26,7	1,7	MR IV 80 - 14 x 160 71 A 6	239
	3,76	0,11	26,7	1,9	MR IV 81 - 14 x 160 71 A 6	239
	4,55	0,11	24	0,85	MR 2IV 50 - 14 x 160 71 A 6	198
	4,42	0,11	24,5	1,4	MR 2IV 63 - 14 x 160 71 A 6	204
4,74	0,11	21,9	1,25	MR IV 63 - 14 x 160 71 A 6	190	
4,74	0,11	21,9	1,32	MR IV 64 - 14 x 160 71 A 6	190	
4,74	0,11	22,6	2,36	MR IV 80 - 14 x 160 71 A 6	190	
5,13	0,11	21,4	0,95	MR 2IV 50 - 11 x 140 63 B 4	273	
5,69	0,12	19,9	1,06	MR 2IV 50 - 14 x 160 71 A 6	158	
5,66	0,12	20	1,8	MR 2IV 63 - 14 x 160 71 A 6	159	
5,92	0,11	18,5	1,6	MR IV 63 - 14 x 160 71 A 6	152	
5,92	0,11	18,5	1,8	MR IV 64 - 14 x 160 71 A 6	152	
6,41	0,12	17,7	1,18	MR 2IV 50 - 11 x 140 63 B 4	218	
6,35	0,1	15,3	0,71	MR IV 50 - 11 x 140 63 B 4	221	
6,99	0,12	15,9	1,25	MR 2IV 50 - 14 x 160 71 A 6	129	
7,1	0,11	14,5	1	MR IV 50 - 14 x 160 71 A 6	127	
7,4	0,12	15,4	2	MR IV 63 - 14 x 160 71 A 6	122	
7,88	0,12	14	0,75	MR 2IV 40 - 11 x 140 63 B 4	178	
7,88	0,12	14,2	1,4	MR 2IV 50 - 11 x 140 63 B 4	178	
8	0,11	13	1,06	MR IV 50 - 11 x 140 63 B 4	175	
8,87	0,11	12	0,67	MR IV 40 - 14 x 160 71 A 6	101	
8,74	0,12	13,2	1,6	MR 2IV 50 - 14 x 160 71 A 6	103	
8,87	0,11	12,3	1,25	MR IV 50 - 14 x 160 71 A 6	101	
8,84	0,12	13,2	2,24	MR IV 63 - 14 x 160 71 A 6	102	
9,85	0,12	11,6	0,95	MR 2IV 40 - 11 x 140 63 B 4	142	
10	0,11	10,7	0,75	MR IV 40 - 11 x 140 63 B 4	140	
9,85	0,12	11,8	1,7	MR 2IV 50 - 11 x 140 63 B 4	142	

1) Powers valid for continuous duty S1; **increase** possible for S2 ... S10 (see ch. 2b) in which case  $P_2$ ,  $M_2$  increase and  $f_s$  decreases proportionately.  
2) For complete designation when ordering see ch. 3.1.



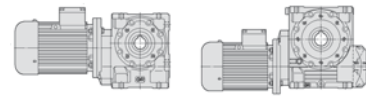


$P_1$ kW	$n_2$ min <sup>-1</sup>	$P_2$ kW	$M_2$ daNm	$f_s$	Riduttore - Motore Gear reducer - Motor				$i$	
					2)					
1)										
0,18	10	0,12	11	1,32	MR IV 50 - 11 × 140	63 B	4	140		
	11,1	0,12	10,1	0,9	MR IV 40 - 14 × 160	71 A	6	81,1		
	11,1	0,12	10,3	1,7	MR IV 50 - 14 × 160	71 A	6	81,1		
	12,3	0,13	10,3	0,95	MR 2IV 40 - 11 × 140	63 B	4	114		
	12,5	0,12	9,1	1	MR IV 40 - 11 × 140	63 B	4	112		
	12,5	0,12	9,2	1,8	MR IV 50 - 11 × 140	63 B	4	112		
	14,2	0,12	8,3	1,18	MR IV 40 - 14 × 160	71 A	6	63,4		
	14,3	0,11	7,2	0,71	MR V 40 - 14 × 160	71 A	6	63		
	14,2	0,13	8,4	2,12	MR IV 50 - 14 × 160	71 A	6	63,4		
	14,3	0,11	7,5	1,32	MR V 50 - 14 × 160	71 A	6	63		
	16,9	0,12	6,8	0,71	MR IV 32 - 11 × 140	63 B	4	82,9		
	16	0,12	7,4	1,25	MR IV 40 - 11 × 140	63 B	4	87,5		
	16	0,13	7,6	2,36	MR IV 50 - 11 × 140	63 B	4	87,5		
	17,7	0,13	6,8	1,5	MR IV 40 - 14 × 160	71 A	6	50,7		
	18	0,12	6,2	1,06	MR V 40 - 14 × 160	71 A	6	50		
	17,7	0,13	7	2,65	MR IV 50 - 14 × 160	71 A	6	50,7		
	18	0,12	6,3	2	MR V 50 - 14 × 160	71 A	6	50		
	20	0,13	6,1	1,6	MR IV 40 - 11 × 140	63 B	4	70		
	21,6	0,13	5,5	0,9	MR IV 32 - 11 × 140	63 B	4	64,8		
	22,2	0,14	6	1,5	MR IV 40 - 14 × 160	71 A	6	40,6		
	22,2	0,11	4,93	1	MR V 40 - 11 × 140	63 B	4	63		
	22,5	0,12	5,2	1,4	MR V 40 - 14 × 160	71 A	6	40		
	22,2	0,12	5,1	1,9	MR V 50 - 11 × 140	63 B	4	63		
	25	0,14	5,3	1,7	MR IV 40 - 11 × 140	63 B	4	56		
	27	0,13	4,59	1,12	MR IV 32 - 11 × 140	63 B	4	51,8		
	28	0,12	4,05	0,8	MR V 32 - 11 × 140	63 B	4	50		
	28,1	0,12	4,24	1	MR V 32 - 11 × 140	71 A	6	32		
	28	0,12	4,16	1,4	MR V 40 - 11 × 140	63 B	4	50		
	28,1	0,13	4,33	1,8	MR V 40 - 14 × 160	71 A	6	32		
	28	0,13	4,28	2,65	MR V 50 - 11 × 140	63 B	4	50		
	33,8	0,14	3,98	1,18	MR IV 32 - 11 × 140	63 B	4	41,5		
	35	0,12	3,4	1,06	MR V 32 - 11 × 140	63 B	4	40		
	36	0,13	3,47	1,32	MR V 32 - 11 × 140	71 A	6	25		
	35	0,13	3,48	1,9	MR V 40 - 11 × 140	63 B	4	40		
	36	0,13	3,51	2,36	MR V 40 - 14 × 160	71 A	6	25		
	43,8	0,13	2,84	1,32	MR V 32 - 11 × 140	63 B	4	32		
	45	0,13	2,86	1,6	MR V 32 - 11 × 140	71 A	6	20		
	43,8	0,13	2,9	2,5	MR V 40 - 11 × 140	63 B	4	32		
	56	0,14	2,31	1,7	MR V 32 - 11 × 140	63 B	4	25		
	56	0,14	2,34	3,15	MR V 40 - 11 × 140	63 B	4	25		
	70	0,14	1,9	2,12	MR V 32 - 11 × 140	63 B	4	20		
	87,5	0,15	1,61	2,24	MR V 32 - 11 × 140	63 B	4	16		
	108	0,15	1,34	2,65	MR V 32 - 11 × 140	63 B	4	13		
	140	0,15	1,05	3,15	MR V 32 - 11 × 140	63 B	4	10		
	175	0,15	0,84	3,35	MR V 32 - 11 × 140	63 A	2	16		
	200	0,16	0,76	3,75	MR V 32 - 11 × 140	63 B	4	7		
	215	0,16	0,69	4	MR V 32 - 11 × 140	63 A	2	13		
	280	0,16	0,54	4,75	MR V 32 - 11 × 140	63 A	2	10		
	0,25	1,49	0,14	90	0,67	MR 2IV 80 - 14 × 160	71 B	6	605	
		1,49	0,14	90	0,75	MR 2IV 81 - 14 × 160	71 B	6	605	
1,86		0,15	77	0,9	MR 2IV 80 - 14 × 160	71 B	6	484		
1,86		0,15	77	0,95	MR 2IV 81 - 14 × 160	71 B	6	484		
2,32		0,15	60	0,95	MR 2IV 80 - 14 × 160	71 A	4	605		
2,32		0,15	60	1,06	MR 2IV 81 - 14 × 160	71 A	4	605		
2,33		0,16	64	1,12	MR 2IV 80 - 14 × 160	71 B	6	387		
2,33		0,16	64	1,25	MR 2IV 81 - 14 × 160	71 B	6	387		
2,98		0,16	51	0,8	MR 2IV 63 - 14 × 160	71 B	6	302		
2,89		0,15	51	1,25	MR 2IV 80 - 14 × 160	71 A	4	484		
2,89		0,15	51	1,4	MR 2IV 81 - 14 × 160	71 A	4	484		
2,98		0,16	52	1,5	MR 2IV 80 - 14 × 160	71 B	6	302		
2,98		0,16	52	1,6	MR 2IV 81 - 14 × 160	71 B	6	302		
3,62		0,16	41	0,85	MR 2IV 63 - 14 × 160	71 A	4	387		
3,62		0,16	41	0,9	MR 2IV 64 - 14 × 160	71 A	4	387		
3,56		0,16	43,2	0,9	MR 2IV 63 - 14 × 160	71 B	6	253		
3,62		0,16	41,9	1,6	MR 2IV 80 - 14 × 160	71 A	4	387		
0,25		3,62	0,16	41,9	1,8	MR 2IV 81 - 14 × 160	71 A	4	387	
		3,56	0,16	44,1	1,7	MR 2IV 80 - 14 × 160	71 B	6	253	
		3,56	0,16	44,1	1,9	MR 2IV 81 - 14 × 160	71 B	6	253	
		3,76	0,14	35,8	0,71	MR IV 64 - 14 × 160	71 B	6	239	
		3,76	0,15	37,1	1,18	MR IV 80 - 14 × 160	71 B	6	239	
		3,76	0,15	37,1	1,32	MR IV 81 - 14 × 160	71 B	6	239	
		4,63	0,16	33,6	1,12	MR 2IV 63 - 14 × 160	71 A	4	302	
		4,63	0,16	33,6	1,18	MR 2IV 64 - 14 × 160	71 A	4	302	
		4,74	0,15	30,4	0,9	MR IV 63 - 14 × 160	71 B	6	190	
		4,74	0,15	30,4	1	MR IV 64 - 14 × 160	71 B	6	190	
		4,63	0,17	34,2	2,12	MR 2IV 80 - 14 × 160	71 A	4	302	
		4,63	0,17	34,2	2,36	MR 2IV 81 - 14 × 160	71 A	4	302	
		4,74	0,16	31,4	1,7	MR IV 80 - 14 × 160	71 B	6	190	
	4,74	0,16	31,4	1,9	MR IV 81 - 14 × 160	71 B	6	190		
	5,13	0,16	29,7	0,67	MR 2IV 50 - 11 × 140	63 C	4	273		
	5,69	0,16	27,6	0,75	MR 2IV 50 - 14 × 160	71 B	6	158		
	5,53	0,16	28,4	1,32	MR 2IV 63 - 14 × 160	71 A	4	253		
	5,53	0,16	28,4	1,4	MR 2IV 64 - 14 × 160	71 A	4	253		
	5,85	0,15	24,3	0,85	MR IV 63 - 14 × 160	71 A	4	239		
	5,85	0,15	24,3	0,95	MR IV 64 - 14 × 160	71 A	4	239		
5,92	0,16	25,7	1,12	MR IV 63 - 14 × 160	71 B	6	152			
5,92	0,16	25,7	1,25	MR IV 64 - 14 × 160	71 B	6	152			
5,85	0,15	25	1,7	MR IV 80 - 14 × 160	71 A	4	239			
5,85	0,15	25	1,9	MR IV 81 - 14 × 160	71 A	4	239			
6,41	0,17	24,6	0,85	MR 2IV 50 - 11 × 140	63 C	4	217			
7,08	0,16	21,9	0,9	MR 2IV 50 - 14 × 160	71 A	4	198			
7,1	0,15	20,2	0,71	MR IV 50 - 14 × 160	71 B	6	127			
6,88	0,16	22,5	1,4	MR 2IV 63 - 14 × 160	71 A	4	204			
6,88	0,16	22,5	1,6	MR 2IV 64 - 14 × 160	71 A	4	204			
7,37	0,16	20,5	1,18	MR IV 63 - 14 × 160	71 A	4	190			
7,37	0,16	20,5	1,4	MR IV 64 - 14 × 160	71 A	4	190			
7,4	0,17	21,4	1,5	MR IV 63 - 14 × 160	71 B	6	122			
7,4	0,17	21,4	1,7	MR IV 64 - 14 × 160	71 B	6	122			
7,88	0,16	19,8	1	MR 2IV 50 - 11 × 140	63 C	4	178			
8	0,15	18,1	0,8	MR IV 50 - 11 × 140	63 C	4	175			
8,85	0,17	18,1	1,12	MR 2IV 50 - 14 × 160	71 A	4	158			
8,87	0,16	17,1	0,9	MR IV 50 - 14 × 160	71 B	6	101			
9,21	0,17	17,2	1,6	MR IV 63 - 14 × 160	71 A	4	152			
9,21	0,17	17,2	1,8	MR IV 64 - 14 × 160	71 A	4	152			
9,85	0,17	16,4	1,25	MR 2IV 50 - 11 × 140	63 C	4	142			
10	0,16	15,3	1	MR IV 50 - 11 × 140	63 C	4	140			
11,1	0,16	14	0,67	MR IV 40 - 14 × 160	71 B	6	81,1			
10,9	0,17	14,7	1,25	MR 2IV 50 - 14 × 160	71 A	4	129			
11	0,16	13,6	1	MR IV 50 - 14 × 160	71 A	4	127			
11,1	0,17	14,3	1,18	MR IV 50 - 14 × 160	71 B	6	81,1			
11,5	0,17	14,3	2	MR IV 63 - 14 × 160	71 A	4	122			
12,5	0,16	12,6	0,75	MR IV 40 - 11 × 140	63 C	4	112			
12,5	0,17	12,8	1,32	MR IV 50 - 11 × 140	63 C	4	112			
13,8	0,16	11,1	0,71	MR IV 40 - 14 × 160	71 A	4	101			
14,2	0,17	11,5	0,85	MR IV 40 - 14 × 160	71 B	6	63,4			
13,6	0,17	12,2	1,6	MR 2IV 50 - 14 × 160	71 A	4	103			
13,8	0,17	11,5	1,25	MR IV 50 - 14 × 160	71 A	4	101			
14,2	0,17	11,7	1,5	MR IV 50 - 14 × 160	71 B	6	63,4			
14,3	0,16	10,4	0,95	MR V 50 - 14 × 160	71 B	6	63			
13,8	0,18	12,2	2,24	MR IV 63 - 14 × 160	71 A	4	102			
14,3	0,16	11	1,7	MR V 63 - 14 × 160	71 B	6	63			
14,3	0,16	11	1,9	MR V 64 - 14 × 160	71 B	6	63			
16	0,17	10,3	0,9	MR IV 40 - 11 × 140	63 C	4	87,5			
17	0,19	10,6	1,7	MR 2IV 50 - 14 × 160	71 A	4	82,4			
16	0,18	10,5	1,7	MR IV 50 - 11 × 140	63 C	4	87,5			
17,										



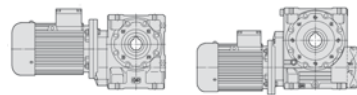
$P_1$ kW 1)	$n_2$ min <sup>-1</sup>	$P_2$ kW	$M_2$ daNm	$f_s$	Riduttore - Motore Gear reducer - Motor 2)				$i$	
0,25	22,1	0,18	7,7	1,18	MR	IV	40 - 14 × 160	71 A	4	63,4
	22,2	0,16	6,9	0,71	MR	V	40 - 11 × 140	63 C	4	63
	22,2	0,16	6,9	0,71	MR	V	40 - 14 × 160	71 A	4	63
	22,5	0,17	7,2	1	MR	V	40 - 14 × 160	71 B	6	40
	22,1	0,18	7,8	2,12	MR	IV	50 - 14 × 160	71 A	4	63,4
	22,2	0,16	7,1	1,4	MR	V	50 - 14 × 160	71 A	4	63
	22,5	0,17	7,4	1,8	MR	V	50 - 14 × 160	71 B	6	40
	22,2	0,17	7,5	2,36	MR	V	63 - 14 × 160	71 A	4	63
	25	0,19	7,4	1,25	MR	IV	40 - 11 × 140	63 C	4	56
	27	0,18	6,4	0,8	MR	IV	32 - 11 × 140	63 C	4	51,8
	28,1	0,17	5,9	0,75	MR	V	32 - 11 × 140	71 B	6	32
	27,6	0,18	6,3	1,5	MR	IV	40 - 14 × 160	71 A	4	50,7
	28	0,17	5,8	1,06	MR	V	40 - 11 × 140	63 C	4	50
	28	0,17	5,8	1,06	MR	V	40 - 14 × 160	71 A	4	50
	28,1	0,18	6	1,32	MR	V	40 - 14 × 160	71 B	6	32
	27,6	0,19	6,4	2,65	MR	IV	50 - 14 × 160	71 A	4	50,7
	28	0,17	5,9	1,9	MR	V	50 - 14 × 160	71 A	4	50
	28,1	0,18	6,1	2,36	MR	V	50 - 14 × 160	71 B	6	32
	33,8	0,2	5,5	0,85	MR	IV	32 - 11 × 140	63 C	4	41,5
	35	0,17	4,73	0,75	MR	V	32 - 11 × 140	63 C	4	40
	36	0,18	4,81	0,9	MR	V	32 - 11 × 140	71 B	6	25
	34,5	0,2	5,5	1,6	MR	IV	40 - 14 × 160	71 A	4	40,6
	35	0,18	4,83	1,32	MR	V	40 - 11 × 140	63 C	4	40
	35	0,18	4,83	1,32	MR	V	40 - 14 × 160	71 A	4	40
	36	0,18	4,88	1,7	MR	V	40 - 14 × 160	71 B	6	25
	35	0,18	4,97	2,36	MR	V	50 - 14 × 160	71 A	4	40
	43,8	0,18	3,94	0,95	MR	V	32 - 11 × 140	63 C	4	32
	43,8	0,18	3,94	0,95	MR	V	32 - 11 × 140	71 A	4	32
	45	0,19	3,97	1,18	MR	V	32 - 11 × 140	71 B	6	20
	43,8	0,18	4,03	1,8	MR	V	40 - 11 × 140	63 C	4	32
	43,8	0,18	4,03	1,8	MR	V	40 - 14 × 160	71 A	4	32
	45	0,19	4,01	2	MR	V	40 - 14 × 160	71 B	6	20
	56	0,19	3,21	1,18	MR	V	32 - 11 × 140	63 C	4	25
	56	0,19	3,21	1,18	MR	V	32 - 11 × 140	71 A	4	25
	56	0,19	3,26	2,24	MR	V	40 - 11 × 140	63 C	4	25
	56	0,19	3,26	2,24	MR	V	40 - 14 × 160	71 A	4	25
	70	0,19	2,64	1,5	MR	V	32 - 11 × 140	63 C	4	20
	70	0,19	2,64	1,5	MR	V	32 - 11 × 140	71 A	4	20
	70	0,2	2,67	2,65	MR	V	40 - 14 × 160	71 A	4	20
	87,5	0,21	2,24	1,6	MR	V	32 - 11 × 140	63 C	4	16
	87,5	0,21	2,24	1,6	MR	V	32 - 11 × 140	71 A	4	16
	87,5	0,21	2,27	2,8	MR	V	40 - 14 × 160	71 A	4	16
	108	0,21	1,86	1,9	MR	V	32 - 11 × 140	63 C	4	13
	108	0,21	1,86	1,9	MR	V	32 - 11 × 140	71 A	4	13
	140	0,21	1,45	2,24	MR	V	32 - 11 × 140	63 C	4	10
140	0,21	1,45	2,24	MR	V	32 - 11 × 140	71 A	4	10	
175	0,21	1,16	2,5	MR	V	32 - 11 × 140	63 B	2	16	
200	0,22	1,05	2,65	MR	V	32 - 11 × 140	63 C	4	7	
200	0,22	1,05	2,65	MR	V	32 - 11 × 140	71 A	4	7	
215	0,22	0,96	2,8	MR	V	32 - 11 × 140	63 B	2	13	
280	0,22	0,75	3,55	MR	V	32 - 11 × 140	63 B	2	10	
400	0,22	0,54	4,25	MR	V	32 - 11 × 140	63 B	2	7	
0,37	1,49	0,22	138	0,85	MR	2IV	100 - 19 × 200	80 A	6	605
	1,86	0,23	116	1,12	MR	2IV	100 - 19 × 200	80 A	6	484
	2,32	0,22	89	0,67	MR	2IV	80 - 14 × 160	71 B	4	605
	2,32	0,22	89	0,71	MR	2IV	81 - 14 × 160	71 B	4	605
	2,33	0,23	94	0,75	MR	2IV	80 - 14 × 160	71 C	6	387
	2,33	0,23	94	0,85	MR	2IV	81 - 14 × 160	71 C	6	387
	2,33	0,23	96	1,4	MR	2IV	100 - 19 × 200	80 A	6	387
	2,89	0,23	75	0,85	MR	2IV	80 - 14 × 160	71 B	4	484
	2,89	0,23	75	0,95	MR	2IV	81 - 14 × 160	71 B	4	484
	2,98	0,24	77	1	MR	2IV	80 - 14 × 160	71 C	6	302
	2,98	0,24	77	1,06	MR	2IV	81 - 14 × 160	71 C	6	302
	2,98	0,25	79	1,9	MR	2IV	100 - 19 × 200	80 A	6	302
	3,62	0,24	62	1,06	MR	2IV	80 - 14 × 160	71 B	4	387
	3,62	0,24	62	1,25	MR	2IV	81 - 14 × 160	71 B	4	387
	3,56	0,25	67	2,24	MR	2IV	100 - 19 × 200	80 A	6	253

$P_1$ kW 1)	$n_2$ min <sup>-1</sup>	$P_2$ kW	$M_2$ daNm	$f_s$	Riduttore - Motore Gear reducer - Motor 2)				$i$	
0,37	3,76	0,22	55	0,8	MR	IV	80 - 14 × 160	71 C	6	239
	3,76	0,22	55	0,9	MR	IV	81 - 14 × 160	71 C	6	239
	3,76	0,23	57	1,5	MR	IV	100 - 19 × 200	80 A	6	239
	4,63	0,24	49,7	0,75	MR	2IV	63 - 14 × 160	71 B	4	302
	4,63	0,24	49,7	0,8	MR	2IV	64 - 14 × 160	71 B	4	302
	4,74	0,22	45	0,67	MR	IV	64 - 14 × 160	71 C	6	190
	4,63	0,25	51	1,4	MR	2IV	80 - 14 × 160	71 B	4	302
	4,63	0,25	51	1,6	MR	2IV	81 - 14 × 160	71 B	4	302
	4,74	0,23	46,5	1,12	MR	IV	80 - 14 × 160	71 C	6	190
	4,74	0,23	46,5	1,25	MR	IV	81 - 14 × 160	71 C	6	190
	4,74	0,24	48,1	2,12	MR	IV	100 - 19 × 200	80 A	6	190
	5,53	0,24	42	0,85	MR	2IV	63 - 14 × 160	71 B	4	253
	5,53	0,24	42	0,95	MR	2IV	64 - 14 × 160	71 B	4	253
	5,85	0,22	35,9	0,67	MR	IV	64 - 14 × 160	71 B	4	239
	5,92	0,24	38	0,75	MR	IV	63 - 14 × 160	71 C	6	152
	5,92	0,24	38	0,85	MR	IV	64 - 14 × 160	71 C	6	152
	5,53	0,25	42,8	1,6	MR	2IV	80 - 14 × 160	71 B	4	253
	5,53	0,25	42,8	1,9	MR	2IV	81 - 14 × 160	71 B	4	253
	5,85	0,23	37	1,18	MR	IV	80 - 14 × 160	71 B	4	239
	5,85	0,23	37	1,32	MR	IV	81 - 14 × 160	71 B	4	239
	5,92	0,24	39,2	1,5	MR	IV	80 - 14 × 160	71 C	6	152
	5,92	0,24	39,2	1,7	MR	IV	81 - 14 × 160	71 C	6	152
	6,88	0,24	33,4	0,95	MR	2IV	63 - 14 × 160	71 B	4	204
	6,88	0,24	33,4	1,06	MR	2IV	64 - 14 × 160	71 B	4	204
	7,09	0,25	33,2	1,06	MR	2IV	63 - 19 × 200	80 A	6	127
	7,09	0,25	33,2	1,18	MR	2IV	64 - 19 × 200	80 A	6	127
	7,37	0,23	30,3	0,8	MR	IV	63 - 14 × 160	71 B	4	190
	7,37	0,23	30,3	0,95	MR	IV	64 - 14 × 160	71 B	4	190
	7,4	0,25	31,6	1	MR	IV	63 - 14 × 160	71 C	6	122
	7,4	0,25	31,6	1,12	MR	IV	64 - 14 × 160	71 C	6	122
	6,88	0,25	34,4	1,8	MR	2IV	80 - 14 × 160	71 B	4	204
	6,88	0,25	34,4	2,12	MR	2IV	81 - 14 × 160	71 B	4	204
	7,37	0,24	31,3	1,5	MR	IV	80 - 14 × 160	71 B	4	190
	7,37	0,24	31,3	1,8	MR	IV	81 - 14 × 160	71 B	4	190
	7,4	0,25	32,6	1,9	MR	IV	80 - 14 × 160	71 C	6	122
	7,4	0,25	32,6	2,24	MR	IV	81 - 14 × 160	71 C	6	122
	8,85	0,25	26,8	0,75	MR	2IV	50 - 14 × 160	71 B	4	158
	8,8	0,25	27,2	1,25	MR	2IV	63 - 14 × 160	71 B	4	159
	8,8	0,25	27,2	1,4	MR	2IV	64 - 14 × 160	71 B	4	159
	9,21	0,25	25,5	1,06	MR	IV	63 - 14 × 160	71 B	4	152
	9,21	0,25	25,5	1,25	MR	IV	64 - 14 × 160	71 B	4	152
	8,84	0,25	27	1,12	MR	IV	63 - 14 × 160	71 C	6	102
	8,84	0,25	27	1,32	MR	IV	64 - 14 × 160	71 C	6	102
	9,21	0,25	26,3	2	MR	IV	80 - 14 × 160	71 B	4	152
	9,21	0,25	26,3	2,36	MR	IV	81 - 14 × 160	71 B	4	152
10,9	0,25	21,8	0,85	MR	2IV	50 - 14 × 160	71 B	4	129	
11	0,23	20,2	0,67	MR	IV	50 - 14 × 160	71 B	4	127	
11,1	0,25	21,2	0,8	MR	IV	50 - 14 × 160	71 C	6	81,1	
11,5	0,25	21,1	1,4	MR	IV	63 - 14 × 160	71 B	4	122	
11,5	0,25	21,1	1,6	MR	IV	64 - 14 × 160	71 B	4	122	
11,5	0,26	21,7	2,65	MR	IV	80 - 14 × 160	71 B	4	122	
13,6	0,26	18	1,06	MR	2IV	50 - 14 × 160	71 B	4	103	
13,8	0,25	17	0,85	MR	IV	50 - 14 × 160	71 B	4	101	
14,2	0,26	17,3	1,06	MR	IV	50 - 14 × 160	71 C	6	63,4	
13,9	0,25	17,4	0,95	MR	IV	50 - 19 × 200	80 A	6	65	
13,8	0,26	18	1,5	MR	IV	63 - 14 × 160	71 B	4	102	
13,8	0,26	18	1,8	MR	IV	64 - 14 × 160	71 B	4	102	
14,3	0,24	16,2	1,18	MR	V	63 - 14 × 160	71 C	6	63	
14,3	0,24	16,2	1,18	MR	V	63 - 19 × 200	80 A	6	63	
14,3	0,24	16,2	1,32	MR	V	64 - 19 × 200	80 A	6	63	
14,3	0,25	16,8	2,24	MR	V	80 - 19 × 200	80 A	6	63	
17	0,28	15,8	1,12	MR	2IV	50 - 14 × 160	71 B	4	82,4	
17,7	0,26	14,1	0,71	MR	IV	40 - 14 × 160	71 C	6	50,7	
17,3	0,26	14,2	1,12	MR	IV	50 - 14 × 160	71 B	4	81,1	
17,7	0,27	14,3	1,32	MR	IV	50 - 14 × 160	71 C	6	50,7	
17,7	0,26	14,2	1,25	MR	IV	50 - 19 × 200	80 A	6	50,8	
18										



$P_1$ kW	$n_2$ min <sup>-1</sup>	$P_2$ kW	$M_2$ daN m	$f_s$	Riduttore - Motore Gear reducer - Motor				$i$
1)					2)				
0,37	22,1	0,26	11,4	0,8	MR IV 40 - 14 x 160	71 B	4	63,4	
	22,5	0,25	10,6	0,67	MR V 40 - 14 x 160	71 C	6	40	
	22,1	0,27	11,6	1,4	MR IV 50 - 14 x 160	71 B	4	63,4	
	22,2	0,29	12,5	1,4	MR IV 50 - 14 x 160	71 C	6	40,6	
	22,2	0,24	10,5	0,95	MR V 50 - 14 x 160	71 B	4	63	
	22,5	0,26	10,9	1,18	MR V 50 - 14 x 160	71 C	6	40	
	22	0,29	12,7	2	MR IV 63 - 14 x 160	71 B	4	63,6	
	22,2	0,26	11	1,6	MR V 63 - 14 x 160	71 B	4	63	
	22,2	0,26	11	1,9	MR V 64 - 14 x 160	71 B	4	63	
	22,5	0,27	11,4	2	MR V 63 - 14 x 160	71 C	6	40	
	22,5	0,27	11,4	2	MR V 63 - 19 x 200	80 A	6	40	
	27,6	0,27	9,4	1	MR IV 40 - 14 x 160	71 B	4	50,7	
	28	0,25	8,6	0,71	MR V 40 - 14 x 160	71 B	4	50	
	28,1	0,26	8,9	0,9	MR V 40 - 14 x 160	71 C	6	32	
	27,6	0,28	9,5	1,8	MR IV 50 - 14 x 160	71 B	4	50,7	
	27,7	0,29	10,1	1,6	MR IV 50 - 19 x 200	80 A	6	32,5	
	28	0,26	8,8	1,25	MR V 50 - 14 x 160	71 B	4	50	
	28,1	0,27	9,1	1,6	MR V 50 - 14 x 160	71 C	6	32	
	28	0,27	9,2	2,12	MR V 63 - 14 x 160	71 B	4	50	
	34,5	0,29	8,1	1,06	MR IV 40 - 14 x 160	71 B	4	40,6	
	35	0,26	7,1	0,9	MR V 40 - 14 x 160	71 B	4	40	
	36	0,27	7,2	1,12	MR V 40 - 14 x 160	71 C	6	25	
	34,5	0,3	8,2	1,9	MR IV 50 - 14 x 160	71 B	4	40,6	
	35	0,27	7,4	1,6	MR V 50 - 14 x 160	71 B	4	40	
	36	0,28	7,4	2	MR V 50 - 14 x 160	71 C	6	25	
	35	0,28	7,6	2,65	MR V 63 - 14 x 160	71 B	4	40	
	43,8	0,27	5,8	0,67	MR V 32 - 11 x 140	71 B	* 4	32	
	45	0,28	5,9	0,8	MR V 32 - 11 x 140	71 C	* 6	20	
	43,8	0,27	6	1,18	MR V 40 - 14 x 160	71 B	4	32	
	45	0,28	5,9	1,4	MR V 40 - 14 x 160	71 C	6	20	
	43,8	0,28	6,1	2	MR V 50 - 14 x 160	71 B	4	32	
	45	0,29	6,1	2,5	MR V 50 - 14 x 160	71 C	6	20	
	56	0,28	4,75	0,8	MR V 32 - 11 x 140	71 B	* 4	25	
	56	0,28	4,82	1,5	MR V 40 - 14 x 160	71 B	4	25	
	56	0,29	4,93	2,65	MR V 50 - 14 x 160	71 B	4	25	
	70	0,29	3,91	1	MR V 32 - 11 x 140	71 B	* 4	20	
	70	0,29	3,96	1,8	MR V 40 - 14 x 160	71 B	4	20	
	87,5	0,3	3,31	1,12	MR V 32 - 11 x 140	71 B	* 4	16	
	87,5	0,31	3,36	1,9	MR V 40 - 14 x 160	71 B	4	16	
	108	0,31	2,75	1,25	MR V 32 - 11 x 140	71 B	* 4	13	
	108	0,31	2,78	2,24	MR V 40 - 14 x 160	71 B	4	13	
	140	0,32	2,15	1,5	MR V 32 - 11 x 140	71 B	* 4	10	
	140	0,32	2,17	2,8	MR V 40 - 14 x 160	71 B	4	10	
	175	0,32	1,72	1,7	MR V 32 - 11 x 140	63 C	2	16	
	175	0,32	1,72	1,7	MR V 32 - 11 x 140	71 A	* 2	16	
	175	0,32	1,74	2,8	MR V 40 - 14 x 160	71 A	2	16	
	200	0,33	1,55	1,8	MR V 32 - 11 x 140	71 B	* 4	7	
	200	0,33	1,57	3,35	MR V 40 - 14 x 160	71 B	4	7	
	215	0,32	1,42	1,9	MR V 32 - 11 x 140	63 C	2	13	
	215	0,32	1,42	1,9	MR V 32 - 11 x 140	71 A	* 2	13	
280	0,32	1,11	2,36	MR V 32 - 11 x 140	63 C	2	10		
280	0,32	1,11	2,36	MR V 32 - 11 x 140	71 A	* 2	10		
400	0,33	0,79	2,8	MR V 32 - 11 x 140	63 C	2	7		
400	0,33	0,79	2,8	MR V 32 - 11 x 140	71 A	* 2	7		

$P_1$ kW	$n_2$ min <sup>-1</sup>	$P_2$ kW	$M_2$ daN m	$f_s$	Riduttore - Motore Gear reducer - Motor				$i$
1)					2)				
0,55	4,33	0,35	76	0,75	MR 2IV 80 - 19 x 200	80 A	4	323	
	4,33	0,35	76	0,9	MR 2IV 81 - 19 x 200	80 A	4	323	
	4,63	0,37	77	1,9	MR 2IV 100 - 19 x 200	80 A	4	302	
	4,74	0,35	72	1,4	MR IV 100 - 19 x 200	80 B	6	190	
	5,53	0,37	64	1,12	MR 2IV 80 - 14 x 160	71 C	4	253	
	5,53	0,37	64	1,25	MR 2IV 81 - 14 x 160	71 C	4	253	
	5,42	0,36	64	1	MR 2IV 80 - 19 x 200	80 A	4	258	
	5,42	0,36	64	1,18	MR 2IV 81 - 19 x 200	80 A	4	258	
	5,85	0,34	55	0,8	MR IV 80 - 14 x 160	71 C	4	239	
	5,85	0,34	55	0,9	MR IV 81 - 14 x 160	71 C	4	239	
	5,63	0,34	57	0,75	MR IV 80 - 19 x 200	80 B	6	160	
	5,63	0,34	57	0,85	MR IV 81 - 19 x 200	80 B	6	160	
	5,53	0,38	66	2,12	MR 2IV 100 - 19 x 200	80 A	4	253	
	5,85	0,35	57	1,5	MR IV 100 - 19 x 200	80 A	4	239	
	5,92	0,37	60	1,9	MR IV 100 - 19 x 200	80 B	6	152	
	6,93	0,37	50	0,71	MR 2IV 63 - 19 x 200	80 A	4	202	
	6,93	0,37	50	0,75	MR 2IV 64 - 19 x 200	80 A	4	202	
	6,93	0,38	52	1,32	MR 2IV 80 - 19 x 200	80 A	4	202	
	6,93	0,38	52	1,5	MR 2IV 81 - 19 x 200	80 A	4	202	
	7,37	0,36	46,5	1	MR IV 80 - 14 x 160	71 C	4	190	
	7,37	0,36	46,5	1,18	MR IV 81 - 14 x 160	71 C	4	190	
	7,09	0,36	48,3	1	MR IV 80 - 19 x 200	80 B	6	127	
	7,09	0,36	48,3	1,18	MR IV 81 - 19 x 200	80 B	6	127	
	7,37	0,37	48,1	2	MR IV 100 - 19 x 200	80 A	4	190	
	8,8	0,37	40,5	0,85	MR 2IV 63 - 14 x 160	71 C	4	159	
	8,8	0,37	40,5	0,95	MR 2IV 64 - 14 x 160	71 C	4	159	
	8,62	0,36	40,4	0,75	MR 2IV 63 - 19 x 200	80 A	4	162	
	8,62	0,36	40,4	0,85	MR 2IV 64 - 19 x 200	80 A	4	162	
	9,21	0,36	37,8	0,71	MR IV 63 - 14 x 160	71 C	4	152	
	9,21	0,36	37,8	0,85	MR IV 64 - 14 x 160	71 C	4	152	
	8,86	0,36	39,3	0,67	MR IV 63 - 19 x 200	80 B	6	102	
	8,86	0,36	39,3	0,8	MR IV 64 - 19 x 200	80 B	6	102	
	8,62	0,37	41,4	1,4	MR 2IV 80 - 19 x 200	80 A	4	162	
	8,62	0,37	41,4	1,7	MR 2IV 81 - 19 x 200	80 A	4	162	
	9,21	0,38	39,1	1,32	MR IV 80 - 14 x 160	71 C	4	152	
	9,21	0,38	39,1	1,6	MR IV 81 - 14 x 160	71 C	4	152	
	8,75	0,36	38,8	1,06	MR IV 80 - 19 x 200	80 A	4	160	
	8,75	0,36	38,8	1,18	MR IV 81 - 19 x 200	80 A	4	160	
	8,86	0,38	40,6	1,32	MR IV 80 - 19 x 200	80 B	6	102	
	8,86	0,38	40,6	1,5	MR IV 81 - 19 x 200	80 B	6	102	
	9,21	0,39	40,3	2,65	MR IV 100 - 19 x 200	80 A	4	152	
	11	0,38	32,8	0,95	MR 2IV 63 - 19 x 200	80 A	4	127	
	11	0,38	32,8	1,12	MR 2IV 64 - 19 x 200	80 A	4	127	
	11,5	0,38	31,4	0,9	MR IV 63 - 14 x 160	71 C	4	122	
	11,5	0,38	31,4	1,12	MR IV 64 - 14 x 160	71 C	4	122	
	11	0,36	31,5	0,71	MR IV 63 - 19 x 200	80 A	4	127	
	11	0,36	31,5	0,85	MR IV 64 - 19 x 200	80 A	4	127	
	11,1	0,38	32,6	0,9	MR IV 63 - 19 x 200	80 B	6	81,2	
	11,1	0,38	32,6	1,06	MR IV 64 - 19 x 200	80 B	6	81,2	
	11	0,39	33,7	1,9	MR 2IV 80 - 19 x 200	80 A	4	127	
11	0,39	33,7	2,24	MR 2IV 81 - 19 x 200	80 A	4	127		
11,5	0,39	32,3	1,8	MR IV 80 - 14 x 160	71 C	4	122		
11,5	0,39	32,3	2,12	MR IV 81 - 14 x 160	71 C	4	122		
11	0,38	32,5	1,4	MR IV 80 - 19 x 200	80 A	4	127		
11	0,38	32,5	1,6	MR IV 81 - 19 x 200	80 A	4	127		
11,1	0,39	33,6	1,7	MR IV 80 - 19 x 200	80 B	6	81,2		
11,1	0,39	33,6	2	MR IV 81 - 19 x 200	80 B	6	81,2		
13,8	0,39	26,8	1,06	MR IV 63 - 14 x 160	71 C	4	102		
13,8	0,39	26,8	1,25	MR IV 64 - 14 x 160	71 C	4	102		
13,8	0,38	26,5	0,95	MR IV 63 - 19 x 200	80 A	4	102		
13,8	0,38	26,5	1,12	MR IV 64 - 19 x 200	80 A	4	102		
14,2	0,39	26,5	1,18	MR IV 63 - 19 x 200	80 B	6	63,5		
14,2	0,39	26,5	1,4	MR IV 64 - 19 x 200	80 B	6	63,5		
14,3	0,36	24,1	0,8	MR V 63 - 19 x 200	80 B	6	63		
14,3	0,36	24,1	0,9	MR V 64 - 19 x 200	80 B	6	63		
13,8	0,4	27,6	2	MR IV 80 - 14 x 160	71 C	4	102		
13,8	0,4	27,6	2,36	MR IV 81 - 14 x 160	71 C	4	102		
13,8	0,39	27,1	1,8	MR IV 80 - 19 x 200	80 A	4	102		
13,8	0,39	27,1	2,12	MR IV 81 - 19 x 200	80 A	4	102		
14,3	0,37	25	1,5	MR V 80 -					



$P_1$ kW	$n_2$ min <sup>-1</sup>	$P_2$ kW	$M_2$ daN m	$f_s$	Riduttore - Motore Gear reducer - Motor			$i$	
1)					2)				
0,55	17,7	0,39	21,1	0,8	MR IV 50 - 19 × 200	80 B	6	50,8	
	17,6	0,4	21,8	1,4	MR IV 63 - 14 × 160	71 C	4	79,5	
	17,6	0,4	21,8	1,6	MR IV 64 - 14 × 160	71 C	4	79,5	
	17,2	0,39	21,8	1,18	MR IV 63 - 19 × 200	80 A	4	81,2	
	17,2	0,39	21,8	1,5	MR IV 64 - 19 × 200	80 A	4	81,2	
	18	0,38	20,2	1,06	MR V 63 - 19 × 200	80 B	6	50	
	18	0,38	20,2	1,25	MR V 64 - 19 × 200	80 B	6	50	
	17,6	0,41	22,3	2,65	MR IV 80 - 14 × 160	71 C	4	79,5	
	17,6	0,41	22,3	3,15	MR IV 81 - 14 × 160	71 C	4	79,5	
	17,2	0,4	22,4	2,36	MR IV 80 - 19 × 200	80 A	4	81,2	
	17,2	0,4	22,4	2,8	MR IV 81 - 19 × 200	80 A	4	81,2	
	18	0,39	20,9	2	MR V 80 - 19 × 200	80 B	6	50	
	18	0,39	20,9	2,36	MR V 81 - 19 × 200	80 B	6	50	
	22,1	0,4	17,2	0,95	MR IV 50 - 14 × 160	71 C	4	63,4	
	21,5	0,39	17,3	0,9	MR IV 50 - 19 × 200	80 A	4	65	
	22,2	0,4	17,4	1,06	MR IV 50 - 19 × 200	80 B	6	40,6	
	22,5	0,38	16,2	0,8	MR V 50 - 19 × 200	80 B	6	40	
	22	0,44	18,9	1,32	MR IV 63 - 14 × 160	71 C	4	63,6	
	22	0,44	18,9	1,6	MR IV 64 - 14 × 160	71 C	4	63,6	
	22,1	0,41	17,7	1,6	MR IV 63 - 19 × 200	80 A	4	63,5	
	22,1	0,41	17,7	1,9	MR IV 64 - 19 × 200	80 A	4	63,5	
	22,2	0,38	16,4	1,06	MR V 63 - 14 × 160	71 C	4	63	
	22,2	0,38	16,4	1,25	MR V 64 - 14 × 160	71 C	4	63	
	22,2	0,38	16,4	1,06	MR V 63 - 19 × 200	80 A	4	63	
	22,2	0,38	16,4	1,25	MR V 64 - 19 × 200	80 A	4	63	
	22,5	0,4	16,9	1,4	MR V 63 - 19 × 200	80 B	6	40	
	22,5	0,4	16,9	1,6	MR V 64 - 19 × 200	80 B	6	40	
	22,2	0,39	16,9	2	MR V 80 - 19 × 200	80 A	4	63	
	22,2	0,39	16,9	2,36	MR V 81 - 19 × 200	80 A	4	63	
	0,41	27,6	0,4	13,9	0,67	MR IV 40 - 14 × 160	71 C	4	50,7
		27,6	0,41	14,2	1,18	MR IV 50 - 14 × 160	71 C	4	50,7
		27,6	0,41	14	1,12	MR IV 50 - 19 × 200	80 A	4	50,8
		28	0,38	13,1	0,85	MR V 50 - 14 × 160	71 C	4	50
		28	0,38	13,1	0,85	MR V 50 - 19 × 200	80 A	4	50
		28,1	0,4	13,5	1,06	MR V 50 - 19 × 200	80 B	6	32
		27,5	0,44	15,4	1,8	MR IV 63 - 14 × 160	71 C	4	50,9
		27,5	0,44	15,4	2,12	MR IV 64 - 14 × 160	71 C	4	50,9
		27,6	0,44	15,3	1,6	MR IV 63 - 19 × 200	80 A	4	50,8
		27,6	0,44	15,3	1,9	MR IV 64 - 19 × 200	80 A	4	50,8
		28	0,4	13,7	1,4	MR V 63 - 14 × 160	71 C	4	50
28		0,4	13,7	1,7	MR V 64 - 14 × 160	71 C	4	50	
28		0,4	13,7	1,4	MR V 63 - 19 × 200	80 A	4	50	
28		0,4	13,7	1,7	MR V 64 - 19 × 200	80 A	4	50	
28,1		0,41	13,9	1,7	MR V 63 - 19 × 200	80 B	6	32	
28,1		0,41	13,9	2,12	MR V 64 - 19 × 200	80 B	6	32	
0,46		34,5	0,43	12	0,71	MR IV 40 - 14 × 160	71 C	4	40,6
		36	0,4	10,7	0,75	MR V 40 - 14 × 160	80 B	6	25
		34,5	0,44	12,2	1,32	MR IV 50 - 14 × 160	71 C	4	40,6
		34,5	0,42	11,5	1,4	MR IV 50 - 19 × 200	80 A	4	40,6
	35	0,4	10,9	1,06	MR V 50 - 14 × 160	71 C	4	40	
	35	0,4	10,9	1,06	MR V 50 - 19 × 200	80 A	4	40	
	36	0,41	11	1,4	MR V 50 - 19 × 200	80 B	6	25	
	34,5	0,45	12,4	2,12	MR IV 63 - 19 × 200	80 A	4	40,6	
	35	0,42	11,4	1,8	MR V 63 - 14 × 160	71 C	4	40	
	35	0,42	11,4	1,8	MR V 63 - 19 × 200	80 A	4	40	
	43,8	0,41	8,9	0,8	MR V 40 - 14 × 160	71 C	4	32	
	45	0,42	8,8	0,9	MR V 40 - 14 × 160	80 B	6	20	
	43,1	0,45	9,9	1,5	MR IV 50 - 19 × 200	80 A	4	32,5	
	43,8	0,42	9,1	1,4	MR V 50 - 14 × 160	71 C	4	32	
	43,8	0,42	9,1	1,4	MR V 50 - 19 × 200	80 A	4	32	
	45	0,42	9	1,7	MR V 50 - 19 × 200	80 B	6	20	
	43,8	0,43	9,3	2,24	MR V 63 - 19 × 200	80 A	4	32	
	56	0,42	7,2	1	MR V 40 - 14 × 160	71 C	4	25	
	56	0,42	7,2	1	MR V 40 - 14 × 160	80 A	4	25	
	56	0,43	7,3	1,8	MR V 50 - 14 × 160	71 C	4	25	
56	0,43	7,3	1,8	MR V 50 - 19 × 200	80 A	4	25		
0,44	70	0,43	5,8	0,71	MR V 32 - 11 × 140	71 C	4	20	
	70	0,43	5,9	1,18	MR V 40 - 14 × 160	71 C	4	20	
	70	0,43	5,9	1,18	MR V 40 - 14 × 160	80 A	4	20	
	70	0,44	6	2,12	MR V 50 - 14 × 160	71 C	4	20	
	70	0,44	6	2,12	MR V 50 - 19 × 200	80 A	4	20	
	87,5	0,45	4,93	0,75	MR V 32 - 11 × 140	71 C	4	16	

$P_1$ kW	$n_2$ min <sup>-1</sup>	$P_2$ kW	$M_2$ daN m	$f_s$	Riduttore - Motore Gear reducer - Motor			$i$	
1)					2)				
0,55	87,5	0,46	4,99	1,32	MR V 40 - 14 × 160	71 C	4	16	
	87,5	0,46	4,99	1,32	MR V 40 - 14 × 160	80 A	4	16	
	87,5	0,46	5,1	2,36	MR V 50 - 14 × 160	71 C	4	16	
	87,5	0,46	5,1	2,36	MR V 50 - 19 × 200	80 A	4	16	
	108	0,46	4,09	0,85	MR V 32 - 11 × 140	71 C	4	13	
	108	0,47	4,13	1,5	MR V 40 - 14 × 160	71 C	4	13	
	108	0,47	4,13	1,5	MR V 40 - 14 × 160	80 A	4	13	
	108	0,47	4,18	2,65	MR V 50 - 14 × 160	71 C	4	13	
	108	0,47	4,18	2,65	MR V 50 - 19 × 200	80 A	4	13	
	140	0,47	3,19	1	MR V 32 - 11 × 140	71 C	4	10	
	140	0,47	3,23	1,8	MR V 40 - 14 × 160	71 C	4	10	
	140	0,47	3,23	1,8	MR V 40 - 14 × 160	80 A	4	10	
	175	0,47	2,56	1,12	MR V 32 - 11 × 140	71 B	2	16	
	175	0,47	2,58	2	MR V 40 - 14 × 160	71 B	2	16	
	200	0,48	2,31	1,25	MR V 32 - 11 × 140	71 C	4	7	
	200	0,49	2,33	2,24	MR V 40 - 14 × 160	71 C	4	7	
	200	0,49	2,33	2,24	MR V 40 - 14 × 160	80 A	4	7	
	215	0,48	2,11	1,32	MR V 32 - 11 × 140	71 B	2	13	
	215	0,48	2,13	2,24	MR V 40 - 14 × 160	71 B	2	13	
	280	0,48	1,64	1,6	MR V 32 - 11 × 140	71 B	2	10	
	280	0,49	1,66	2,8	MR V 40 - 14 × 160	71 B	2	10	
	400	0,49	1,18	1,9	MR V 32 - 11 × 140	71 B	2	7	
	400	0,5	1,19	3,35	MR V 40 - 14 × 160	71 B	2	7	
	0,75	1,5	0,45	286	0,75	MR 2IV 125 - 24 × 200	90 S	6	602
		1,87	0,46	236	1	MR 2IV 125 - 24 × 200	90 S	6	481
		2,33	0,48	195	0,71	MR 2IV 100 - 19 × 200	80 C	6	387
		2,34	0,48	198	1,32	MR 2IV 125 - 24 × 200	90 S	6	385
		2,89	0,47	155	0,8	MR 2IV 100 - 19 × 200	80 B	4	484
		2,98	0,5	160	0,95	MR 2IV 100 - 19 × 200	80 C	6	302
		2,88	0,49	162	1,5	MR 2IV 125 - 24 × 200	90 S	6	312
		2,88	0,49	162	1,7	MR 2IV 126 - 24 × 200	90 S	6	312
		3,62	0,49	128	1,06	MR 2IV 100 - 19 × 200	80 B	4	387
		3,55	0,48	130	1,6	MR 2IV 125 - 24 × 200	90 S	6	254
		3,55	0,48	130	1,9	MR 2IV 126 - 24 × 200	90 S	6	254
		3,7	0,47	121	1,32	MR IV 125 - 24 × 200	90 S	6	243
		3,7	0,47	121	1,6	MR IV 126 - 24 × 200	90 S	6	243
		3,76	0,46	116	0,75	MR IV 100 - 19 × 200	80 C	6	239
		4,46	0,5	107	0,75	MR 2IV 81 - 19 × 200	80 C	6	202
		4,63	0,51	105	1,4	MR 2IV 100 - 19 × 200	80 B	4	302
		4,74	0,48	98	1	MR IV 100 - 19 × 200	80 C	6	190
4,67		0,5	102	1,8	MR IV 125 - 24 × 200	90 S	6	193	
4,67		0,5	102	2,12	MR IV 126 - 24 × 200	90 S	6	193	
5,42		0,49	87	0,75	MR 2IV 80 - 19 × 200	80 B	4	258	
5,42		0,49	87	0,85	MR 2IV 81 - 19 × 200	80 B	4	258	
5,53		0,52	89	1,6	MR 2IV 100 - 19 × 200	80 B	4	253	
5,85		0,48	78	1,06	MR IV 100 - 19 × 200	80 B	4	239	
5,92		0,51	82	1,4	MR IV 100 - 19 × 200	80 C	6	152	
5,83		0,51	84	2,36	MR IV 125 - 24 × 200	90 S	6	154	
6,93		0,51	71	0,95	MR 2IV 80 - 19 × 200	80 B	4	202	
6,93		0,51	71	1,12	MR 2IV 81 - 19 × 200	80 B	4	202	
7,09		0,49	66	0,71	MR IV 80 - 19 × 200	80 C	6	127	
7,09		0,49	66	0,85	MR IV 81 - 19 × 200	80 C	6	127	
6,88		0,51	71	1,8	MR 2IV 100 - 19 × 200	80 B	4	204	
7,37		0,51	66	1,4	MR IV 100 - 19 × 200	80 B	4	190	
7,4		0,52	68	1,9	MR IV 100 - 19 × 200	80 C	6	122	
8,62		0,51	57	1,06	MR 2IV 80 - 19 × 200	80 B	4	162	
8,62		0,51	57	1,25	MR 2IV 81 - 19 × 200	80 B	4	162	
8,75		0,48	53	0,75	MR IV 80 - 19 × 200	80 B	4	160	
8,75		0,48	53	0,9	MR IV 81 - 19 × 200	80 B	4	160	
8,86		0,51	55	0,95	MR IV 80 - 19 × 200	80 C	6	102	
8,86		0,51	55	1,12	MR IV 81 - 19 × 200	80 C	6	102	
9,21		0,53	55	2	MR IV 100 - 19 × 200	80 B	4	152	
11		0,52	44,8	0,71	MR 2IV 63 - 19 × 200	80 B	4	127	
11	0,52	44,8	0,85	MR 2IV 64 - 19 × 200	80 B	4	127		
11,1	0,52	44,4	0,67	MR IV 63 - 19 × 200	80 C	6	81,2		
11,1	0,52	44,4	0,75	MR IV 64 - 19 × 200	80 C	6	81,2		
11	0,53	45,9	1,4	MR 2IV 80 - 19 × 200	80 B	4	127		

Values in red state nominal thermal power  $P_{th}$  (ambient temperature 40 °C, continuous duty, see ch. 3.2).

Motor (cat.TX) with efficiency value not according to IE3 class (IEC 60034-30).

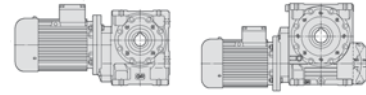
Nominal power and nameplate data refer to intermittent periodic duty S3 70%.

1) Powers valid for continuous duty S1; increase possible for S2 ... S10 (see ch. 2b) in which case  $P_2$ ,  $M_2$  increase and  $f_s$  decreases proportionately.

2) For complete designation when ordering see ch. 3.1.

\* Mounting position **B5R** available also for mounting position **B5** (see table ch. 2b).

# Gearmotors selection tables



3.7

$P_1$ kW 1)	$n_2$ min <sup>-1</sup>	$P_2$ kW	$M_2$ daN m	$f_s$	Riduttore - Motore Gear reducer - Motor 2)	$i$		
0,75	11	0,53	45,9	1,6	MR 2IV 81 - 19 x 200	80 B 4	127	
	11	0,51	44,4	1	MR IV 80 - 19 x 200	80 B 4	127	
	11	0,51	44,4	1,18	MR IV 81 - 19 x 200	80 B 4	127	
	11,1	0,53	45,8	1,25	MR IV 80 - 19 x 200	80 C 6	81,2	
	11,1	0,53	45,8	1,5	MR IV 81 - 19 x 200	80 C 6	81,2	
	11,5	0,54	45,2	2,65	MR IV 100 - 19 x 200	80 B 4	122	
	13,8	0,52	36,1	0,71	MR IV 63 - 19 x 200	80 B 4	102	
	13,8	0,52	36,1	0,85	MR IV 64 - 19 x 200	80 B 4	102	
	14,2	0,54	36,2	0,85	MR IV 63 - 19 x 200	80 C 6	63,5	
	14,2	0,54	36,2	1	MR IV 64 - 19 x 200	80 C 6	63,5	
	14,1	0,53	35,8	0,8	MR IV 63 - 24 x 200	90 S 6	64	
	14,3	0,49	32,9	0,67	MR V 64 - 19 x 200	80 C 6	63	
	14,3	0,49	32,9	0,67	MR V 64 - 24 x 200	90 S 6	63	
	13,8	0,53	37	1,32	MR IV 80 - 19 x 200	80 B 4	102	
	13,8	0,53	37	1,6	MR IV 81 - 19 x 200	80 B 4	102	
	14,2	0,55	37,1	1,6	MR IV 80 - 19 x 200	80 C 6	63,5	
	14,2	0,55	37,1	1,9	MR IV 81 - 19 x 200	80 C 6	63,5	
	14,3	0,51	34,1	1,06	MR V 80 - 24 x 200	90 S 6	63	
	14,3	0,51	34,1	1,32	MR V 81 - 24 x 200	90 S 6	63	
	14,3	0,53	35,4	2,12	MR V 100 - 24 x 200	90 S 6	63	
	17,2	0,54	29,8	0,9	MR IV 63 - 19 x 200	80 B 4	81,2	
	17,2	0,54	29,8	1,06	MR IV 64 - 19 x 200	80 B 4	81,2	
	18	0,55	29,1	1	MR IV 63 - 24 x 200	90 S 6	50	
	18	0,55	29,1	1,18	MR IV 64 - 24 x 200	90 S 6	50	
	18	0,52	27,6	0,75	MR V 63 - 19 x 200	80 C 6	50	
	18	0,52	27,6	0,9	MR V 64 - 19 x 200	80 C 6	50	
	18	0,52	27,6	0,75	MR V 63 - 24 x 200	90 S 6	50	
	18	0,52	27,6	0,9	MR V 64 - 24 x 200	90 S 6	50	
	17,2	0,55	30,6	1,7	MR IV 80 - 19 x 200	80 B 4	81,2	
	17,2	0,55	30,6	2	MR IV 81 - 19 x 200	80 B 4	81,2	
	18	0,56	29,8	1,9	MR IV 80 - 24 x 200	90 S 6	50	
	18	0,54	28,5	1,5	MR V 80 - 24 x 200	90 S 6	50	
	18	0,54	28,5	1,7	MR V 81 - 24 x 200	90 S 6	50	
	18	0,55	29,4	2,65	MR V 100 - 24 x 200	90 S 6	50	
	0,58	22,2	0,55	23,7	0,75	MR IV 50 - 19 x 200	80 C 6	40,6
		22,1	0,56	24,1	1,18	MR IV 63 - 19 x 200	80 B 4	63,5
		22,1	0,56	24,1	1,4	MR IV 64 - 19 x 200	80 B 4	63,5
		22,2	0,52	22,4	0,75	MR V 63 - 19 x 200	80 B 4	63
		22,2	0,52	22,4	0,9	MR V 64 - 19 x 200	80 B 4	63
		22,5	0,54	23	1	MR V 63 - 19 x 200	80 C 6	40
		22,5	0,54	23	1,18	MR V 64 - 19 x 200	80 C 6	40
		22,5	0,54	23	1	MR V 63 - 24 x 200	90 S 6	40
		22,5	0,54	23	1,18	MR V 64 - 24 x 200	90 S 6	40
		22,1	0,57	24,7	2,24	MR IV 80 - 19 x 200	80 B 4	63,5
		22,1	0,57	24,7	2,65	MR IV 81 - 19 x 200	80 B 4	63,5
22,2		0,54	23,1	1,5	MR V 80 - 19 x 200	80 B 4	63	
22,2		0,54	23,1	1,7	MR V 81 - 19 x 200	80 B 4	63	
22,5		0,56	23,7	1,9	MR V 80 - 24 x 200	90 S 6	40	
22,5		0,56	23,7	2,24	MR V 81 - 24 x 200	90 S 6	40	
0,63		27,6	0,55	19,2	0,85	MR IV 50 - 19 x 200	80 B 4	50,8
		28,1	0,54	18,4	0,8	MR V 50 - 19 x 200	80 C 6	32
		27,6	0,6	20,8	1,18	MR IV 63 - 19 x 200	80 B 4	50,8
		27,6	0,6	20,8	1,4	MR IV 64 - 19 x 200	80 B 4	50,8
		28,1	0,6	20,5	1,32	MR IV 63 - 24 x 200	90 S 6	32
		28,1	0,6	20,5	1,6	MR IV 64 - 24 x 200	90 S 6	32
		28	0,55	18,6	1,06	MR V 63 - 19 x 200	80 B 4	50
		28	0,55	18,6	1,25	MR V 64 - 19 x 200	80 B 4	50
		28,1	0,56	19	1,32	MR V 63 - 19 x 200	80 C 6	32
		28,1	0,56	19	1,5	MR V 64 - 19 x 200	80 C 6	32
	28,1	0,56	19	1,32	MR V 63 - 24 x 200	90 S 6	32	
	28,1	0,56	19	1,5	MR V 64 - 24 x 200	90 S 6	32	
	27,6	0,61	21,2	2,24	MR IV 80 - 19 x 200	80 B 4	50,8	
	27,6	0,61	21,2	2,65	MR IV 81 - 19 x 200	80 B 4	50,8	
	28	0,56	19,2	1,9	MR V 80 - 19 x 200	80 B 4	50	
	28	0,56	19,2	2,24	MR V 81 - 19 x 200	80 B 4	50	
	28,1	0,57	19,5	2,36	MR V 80 - 24 x 200	90 S 6	32	
	34,5	0,57	15,7	1	MR IV 50 - 19 x 200	80 B 4	40,6	
	35	0,55	14,9	0,8	MR V 50 - 19 x 200	80 B 4	40	
	36	0,56	14,9	1	MR V 50 - 19 x 200	80 C 6	25	
	34,5	0,61	17	1,6	MR IV 63 - 19 x 200	80 B 4	40,6	
	34,5	0,61	17	1,8	MR IV 64 - 19 x 200	80 B 4	40,6	
	35	0,57	15,5	1,32	MR V 63 - 19 x 200	80 B 4	40	

$P_1$ kW 1)	$n_2$ min <sup>-1</sup>	$P_2$ kW	$M_2$ daN m	$f_s$	Riduttore - Motore Gear reducer - Motor 2)	$i$			
0,75	35	0,57	15,5	1,6	MR V 64 - 19 x 200	80 B 4	40		
	36	0,58	15,3	1,7	MR V 63 - 19 x 200	80 C 6	25		
	36	0,58	15,3	2	MR V 64 - 19 x 200	80 C 6	25		
	36	0,58	15,3	1,7	MR V 63 - 24 x 200	90 S 6	25		
	36	0,58	15,3	2	MR V 64 - 24 x 200	90 S 6	25		
	35	0,58	15,8	2,5	MR V 80 - 19 x 200	80 B 4	40		
	0,5	45	0,57	12	0,67	MR V 40 - 14 x 160	80 C * 6	20	
		43,1	0,61	13,5	1,12	MR IV 50 - 19 x 200	80 B 4	32,5	
		43,8	0,57	12,4	1	MR V 50 - 19 x 200	80 B 4	32	
		45	0,58	12,3	1,18	MR V 50 - 19 x 200	80 C 6	20	
		43,8	0,58	12,7	1,7	MR V 63 - 19 x 200	80 B 4	32	
		43,8	0,58	12,7	2	MR V 64 - 19 x 200	80 B 4	32	
		0,55	56	0,57	9,8	0,75	MR V 40 - 14 x 160	80 B * 4	25
			56	0,59	10	1,32	MR V 50 - 19 x 200	80 B 4	25
			56	0,6	10,2	2,12	MR V 63 - 19 x 200	80 B 4	25
0,6			70	0,59	8	0,9	MR V 40 - 14 x 160	80 B * 4	20
	70		0,6	8,2	1,6	MR V 50 - 19 x 200	80 B 4	20	
	70	0,63	8,6	2,24	MR V 63 - 19 x 200	80 B 4	20		
	87,5	0,62	6,8	0,95	MR V 40 - 14 x 160	80 B * 4	16		
	87,5	0,63	6,9	1,7	MR V 50 - 19 x 200	80 B 4	16		
87,5	0,64	7	2,8	MR V 63 - 19 x 200	80 B 4	16			
108	0,63	5,6	1,12	MR V 40 - 14 x 160	80 B * 4	13			
108	0,64	5,7	2	MR V 50 - 19 x 200	80 B 4	13			
140	0,61	4,16	0,75	MR V 32 - 11 x 140	71 C * 2	20			
140	0,65	4,4	1,32	MR V 40 - 14 x 160	80 B * 4	10			
140	0,65	4,44	2,36	MR V 50 - 19 x 200	80 B 4	10			
175	0,64	3,49	0,8	MR V 32 - 11 x 140	71 C * 2	16			
175	0,64	3,52	1,4	MR V 40 - 14 x 160	71 C 2	16			
175	0,64	3,52	1,4	MR V 40 - 14 x 160	80 A * 2	16			
175	0,65	3,56	2,5	MR V 50 - 14 x 160	71 C 2	16			
175	0,65	3,56	2,5	MR V 50 - 19 x 200	80 A 2	16			
200	0,66	3,18	1,6	MR V 40 - 14 x 160	80 B * 4	7			
200	0,67	3,2	3	MR V 50 - 19 x 200	80 B 4	7			
215	0,65	2,88	0,95	MR V 32 - 11 x 140	71 C * 2	13			
215	0,65	2,9	1,7	MR V 40 - 14 x 160	71 C 2	13			
215	0,65	2,9	1,7	MR V 40 - 14 x 160	80 A * 2	13			
215	0,66	2,93	3	MR V 50 - 14 x 160	71 C 2	13			
215	0,66	2,93	3	MR V 50 - 19 x 200	80 A 2	13			
280	0,66	2,24	1,18	MR V 32 - 11 x 140	71 C * 2	10			
280	0,66	2,26	2	MR V 40 - 14 x 160	71 C 2	10			
280	0,66	2,26	2	MR V 40 - 14 x 160	80 A * 2	10			
400	0,67	1,61	1,4	MR V 32 - 11 x 140	71 C * 2	7			
400	0,68	1,62	2,5	MR V 40 - 14 x 160	71 C 2	7			
400	0,68	1,62	2,5	MR V 40 - 14 x 160	80 A * 2	7			
1,1	1,87	0,68	346	0,71	MR 2IV 126 - 24 x 200	90 L 6	481		
	2,33	0,67	277	0,75	MR 2IV 125 - 24 x 200	90 S 4	602		
	2,33	0,67	277	0,8	MR 2IV 126 - 24 x 200	90 S 4	602		
	2,34	0,71	290	0,9	MR 2IV 125 - 24 x 200	90 L 6	385		
	2,34	0,71	290	0,95	MR 2IV 126 - 24 x 200	90 L 6	385		
	2,91	0,7	228	0,95	MR 2IV 125 - 24 x 200	90 S 4	481		
	2,91	0,7	228	1,06	MR 2IV 126 - 24 x 200	90 S 4	481		
	2,88	0,72	238	1,06	MR 2IV 125 - 24 x 200	90 L 6	312		
	3,62	0,71	188	0,71	MR 2IV 100 - 19 x 200	80 C 4	387		
	3,64	0,73	192	1,25	MR 2IV 125 - 24 x 200	90 S 4	385		
	3,64	0,73	192	1,4	MR 2IV 126 - 24 x 200	90 S 4	385		
	3,7	0,69	178	0,95	MR IV 125 - 24 x 200	90 L 6	243		
	3,7	0,69	178	1,06	MR IV 126 - 24 x 200	90 L 6	243		
	4,63	0,75	154	0,95	MR 2IV 100 - 19 x 200	80 C 4	302		
	4,49	0,75	159	1,4	MR 2IV 125 - 24 x 200	90 S 4	312		
	4,49	0,75	159	1,7	MR 2IV 126 - 24 x 200	90 S 4	312		
	4,67	0,73	149	1,18	MR IV 125 - 24 x 200	90 L 6	193		
	4,67	0,73	149	1,4	MR IV 126 - 24 x 200	90 L 6	193		
	5,53	0,76	131	1,06	MR 2IV 100 - 19 x 200	80 C 4	253		
	5,42	0,74	131	1	MR 2IV 100 - 24 x 200	90 S 4	258		
	5,85	0,7	115	0,75	MR IV 100 - 19 x 200	80 C 4	239		
	5,63	0,7	119	0,71	MR IV 100 - 24 x 200	90 L 6	160		
	5,52	0,74	128	1,5	MR 2IV 125 - 24 x 200	90 S 4	254		
	5,52	0,74	128	1,8	MR 2IV 126 - 24 x 200	90 S 4	254		

Values in red state nominal thermal power  $P_{Tn}$  (ambient temperature 40 °C, continuous duty, see ch. 3.2).

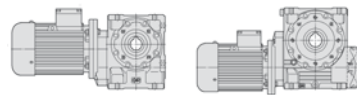
Motor (cat.TX) with efficiency value not according to IE3 class (IEC 60034-30).

Nominal power and nameplate data refer to intermittent periodic duty S3 70%.

1) Powers valid for continuous duty S1; increase possible for S2... S10 (see ch. 2b) in which case  $P_2$ ,  $M_2$  increase and  $f_s$  decreases proportionately.

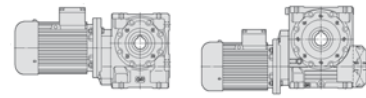
2) For complete designation when ordering see ch. 3.1.

\* Mounting position **B5R**, available also for mounting position **B5** (see table ch. 2b).



$P_1$ kW 1)	$n_2$ min <sup>-1</sup>	$P_2$ kW	$M_2$ daNm	$f_s$	Riduttore - Motore Gear reducer - Motor				$i$			
					2)							
1,1	5,76	0,73	120	1,25	MR	IV	125 - 24 × 200	90 S	4	243		
	5,76	0,73	120	1,5	MR	IV	126 - 24 × 200	90 S	4	243		
	5,83	0,75	123	1,6	MR	IV	125 - 24 × 200	90 L	6	154		
	5,83	0,75	123	1,9	MR	IV	126 - 24 × 200	90 L	6	154		
	0,92	6,93	0,75	104	0,75	MR	2IV	81 - 19 × 200	80 C	4	202	
		6,93	0,77	106	1,32	MR	2IV	100 - 24 × 200	90 S	4	202	
		7,37	0,74	96	1	MR	IV	100 - 19 × 200	80 C	4	190	
		7,09	0,74	100	0,95	MR	IV	100 - 24 × 200	90 L	6	127	
		6,9	0,77	107	2	MR	2IV	125 - 24 × 200	90 S	4	203	
		7,26	0,76	100	1,6	MR	IV	125 - 24 × 200	90 S	4	193	
7,26		0,76	100	1,9	MR	IV	126 - 24 × 200	90 S	4	193		
7,2		0,77	102	1,8	MR	IV	125 - 24 × 200	90 L	6	125		
8,62		0,75	83	0,71	MR	2IV	80 - 19 × 200	80 C	4	162		
8,62		0,75	83	0,85	MR	2IV	81 - 19 × 200	80 C	4	162		
9	9	0,73	78	0,71	MR	IV	81 - 24 × 200	90 L	6	100		
	8,8	0,79	85	1,6	MR	2IV	100 - 19 × 200	80 C	4	159		
	8,62	0,77	85	1,5	MR	2IV	100 - 24 × 200	90 S	4	162		
	9,21	0,78	81	1,32	MR	IV	100 - 19 × 200	80 C	4	152		
	8,75	0,74	80	1	MR	IV	100 - 24 × 200	90 S	4	160		
	8,86	0,78	84	1,25	MR	IV	100 - 24 × 200	90 L	6	102		
	9,07	0,79	83	2,24	MR	IV	125 - 24 × 200	90 S	4	154		
	11	0,78	67	0,95	MR	2IV	80 - 19 × 200	80 C	4	127		
	11	0,78	67	1,12	MR	2IV	81 - 19 × 200	80 C	4	127		
	11	0,75	65	0,71	MR	IV	80 - 19 × 200	80 C	4	127		
11,1	11	0,75	65	0,8	MR	IV	81 - 19 × 200	80 C	4	127		
	11,1	0,73	63	0,71	MR	IV	81 - 24 × 200	90 S	4	126		
	11,3	0,77	65	0,8	MR	IV	80 - 24 × 200	90 L	6	80		
	11,3	0,77	65	0,9	MR	IV	81 - 24 × 200	90 L	6	80		
	11	0,8	69	1,9	MR	2IV	100 - 24 × 200	90 S	4	127		
	11,5	0,8	66	1,8	MR	IV	100 - 19 × 200	80 C	4	122		
	11	0,78	67	1,32	MR	IV	100 - 24 × 200	90 S	4	127		
	11,1	0,8	69	1,7	MR	IV	100 - 24 × 200	90 L	6	81,2		
	13,8	0,84	58	0,9	MR	2IV	80 - 19 × 200	80 C	4	102		
	13,8	0,84	58	1,06	MR	2IV	81 - 19 × 200	80 C	4	102		
13,8	13,8	0,78	54	0,9	MR	IV	80 - 19 × 200	80 C	4	102		
	13,8	0,78	54	1,06	MR	IV	81 - 19 × 200	80 C	4	102		
	14	0,77	52	0,8	MR	IV	80 - 24 × 200	90 S	4	100		
	14	0,77	52	1	MR	IV	81 - 24 × 200	90 S	4	100		
	14,1	0,8	54	1	MR	IV	80 - 24 × 200	90 L	6	64		
	14,1	0,8	54	1,18	MR	IV	81 - 24 × 200	90 L	6	64		
	14,3	0,75	50	0,75	MR	V	80 - 24 × 200	90 L	6	63		
	14,3	0,75	50	0,9	MR	V	81 - 24 × 200	90 L	6	63		
	13,8	0,86	60	1,9	MR	2IV	100 - 24 × 200	90 S	4	102		
	13,8	0,81	56	2	MR	IV	100 - 19 × 200	80 C	4	102		
13,8	13,8	0,81	56	1,8	MR	IV	100 - 24 × 200	90 S	4	102		
	14,2	0,83	56	2,24	MR	IV	100 - 24 × 200	90 L	6	63,5		
	14,3	0,78	52	1,4	MR	V	100 - 24 × 200	90 L	6	63		
	0,8	17,2	0,79	43,7	0,71	MR	IV	64 - 19 × 200	80 C	4	81,2	
		0,82	18	0,8	42,6	0,71	MR	IV	63 - 24 × 200	90 L	6	50
		0,82	18	0,8	42,6	0,85	MR	IV	64 - 24 × 200	90 L	6	50
		17,2	0,81	44,8	1,18	MR	IV	80 - 19 × 200	80 C	4	81,2	
		17,2	0,81	44,8	1,4	MR	IV	81 - 19 × 200	80 C	4	81,2	
		17,5	0,8	43,6	1,06	MR	IV	80 - 24 × 200	90 S	4	80	
		17,5	0,8	43,6	1,32	MR	IV	81 - 24 × 200	90 S	4	80	
18		0,82	43,7	1,32	MR	IV	80 - 24 × 200	90 L	6	50		
18		0,82	43,7	1,6	MR	IV	81 - 24 × 200	90 L	6	50		
18		0,79	41,7	1	MR	V	80 - 24 × 200	90 L	6	50		
18	18	0,79	41,7	1,18	MR	V	81 - 24 × 200	90 L	6	50		
	17,2	0,83	45,9	2,36	MR	IV	100 - 24 × 200	90 S	4	81,2		
	18	0,81	43,2	1,8	MR	V	100 - 24 × 200	90 L	6	50		
	0,88	22,1	0,82	35,4	0,8	MR	IV	63 - 19 × 200	80 C	4	63,5	
		0,88	22,1	0,82	35,4	0,95	MR	IV	64 - 19 × 200	80 C	4	63,5
		0,87	21,9	0,8	35,1	0,75	MR	IV	63 - 24 × 200	90 S	4	64
		0,87	21,9	0,8	35,1	0,85	MR	IV	64 - 24 × 200	90 S	4	64
		0,88	22,5	0,8	33,8	0,8	MR	V	64 - 24 × 200	90 L	6	40
		22,1	0,84	36,2	1,5	MR	IV	80 - 19 × 200	80 C	4	63,5	
		22,1	0,84	36,2	1,8	MR	IV	81 - 19 × 200	80 C	4	63,5	
21,9		0,83	36,1	1,4	MR	IV	80 - 24 × 200	90 S	4	64		
21,9		0,83	36,1	1,6	MR	IV	81 - 24 × 200	90 S	4	64		
22,2		0,79	33,8	1	MR	V	80 - 19 × 200	80 C	4	63		
22,2	22,2	0,79	33,8	1,18	MR	V	81 - 19 × 200	80 C	4	63		
	22,2	0,79	33,8	1	MR	V	80 - 24 × 200	90 S	4	63		

$P_1$ kW 1)	$n_2$ min <sup>-1</sup>	$P_2$ kW	$M_2$ daNm	$f_s$	Riduttore - Motore Gear reducer - Motor				$i$			
					2)							
1,1	22,2	0,79	33,8	1,18	MR	V	81 - 24 × 200	90 S	4	63		
	22,5	0,82	34,7	1,32	MR	V	80 - 24 × 200	90 L	6	40		
	22,5	0,82	34,7	1,5	MR	V	81 - 24 × 200	90 L	6	40		
	22,1	0,86	37,2	3	MR	IV	100 - 24 × 200	90 S	4	63,5		
	22,2	0,82	35	1,9	MR	V	100 - 24 × 200	90 S	4	63		
	27,6	27,6	0,88	30,6	0,8	MR	IV	63 - 19 × 200	80 C	4	50,8	
		27,6	0,88	30,6	0,95	MR	IV	64 - 19 × 200	80 C	4	50,8	
		28	0,83	28,4	0,95	MR	IV	63 - 24 × 200	90 S	4	50	
		28	0,83	28,4	1,12	MR	IV	64 - 24 × 200	90 S	4	50	
		28,1	0,89	30,1	0,9	MR	IV	63 - 24 × 200	90 L	6	32	
28		0,8	27,3	0,71	MR	V	63 - 19 × 200	80 C	4	50		
28		0,8	27,3	0,85	MR	V	64 - 19 × 200	80 C	4	50		
28		0,8	27,3	0,71	MR	V	63 - 24 × 200	90 S	4	50		
28		0,8	27,3	0,85	MR	V	64 - 24 × 200	90 S	4	50		
28,1		0,82	27,8	0,85	MR	V	63 - 24 × 200	90 L	6	32		
27,6	28,1	0,82	27,8	1,06	MR	V	64 - 24 × 200	90 L	6	32		
	27,6	0,9	31	1,5	MR	IV	80 - 19 × 200	80 C	4	50,8		
	27,6	0,9	31	1,8	MR	IV	81 - 19 × 200	80 C	4	50,8		
	28	0,85	29,1	1,8	MR	IV	80 - 24 × 200	90 S	4	50		
	28	0,85	29,1	2,12	MR	IV	81 - 24 × 200	90 S	4	50		
	28	0,82	28,1	1,32	MR	V	80 - 19 × 200	80 C	4	50		
	28	0,82	28,1	1,6	MR	V	81 - 19 × 200	80 C	4	50		
	28	0,82	28,1	1,32	MR	V	80 - 24 × 200	90 S	4	50		
	28	0,82	28,1	1,6	MR	V	81 - 24 × 200	90 S	4	50		
	28,1	0,84	28,6	1,6	MR	V	80 - 24 × 200	90 L	6	32		
28,1	28,1	0,84	28,6	1,9	MR	V	81 - 24 × 200	90 L	6	32		
	0,69	34,5	0,83	23,1	0,71	MR	IV	50 - 19 × 200	80 C	4	40,6	
		0,69	36	0,83	21,9	0,67	MR	V	50 - 19 × 200	90 L	6	25
		34,5	0,9	24,9	1,06	MR	IV	63 - 19 × 200	80 C	4	40,6	
		34,5	0,9	24,9	1,25	MR	IV	64 - 19 × 200	80 C	4	40,6	
		35	0,89	24,4	1	MR	IV	63 - 24 × 200	90 S	4	40	
		35	0,89	24,4	1,18	MR	IV	64 - 24 × 200	90 S	4	40	
		35	0,83	22,7	0,9	MR	V	63 - 19 × 200	80 C	4	40	
		35	0,83	22,7	1,06	MR	V	64 - 19 × 200	80 C	4	40	
		35	0,83	22,7	0,9	MR	V	63 - 24 × 200	90 S	4	40	
35		0,83	22,7	1,06	MR	V	64 - 24 × 200	90 S	4	40		
36	36	0,85	22,5	1,12	MR	V	63 - 24 × 200	90 L	6	25		
	36	0,85	22,5	1,32	MR	V	64 - 24 × 200	90 L	6	25		
	34,5	0,91	25,3	2	MR	IV	80 - 19 × 200	80 C	4	40,6		
	34,5	0,91	25,3	2,36	MR	IV	81 - 19 × 200	80 C	4	40,6		
	35	0,91	24,7	1,8	MR	IV	80 - 24 × 200	90 S	4	40		
	35	0,91	24,7	2,12	MR	IV	81 - 24 × 200	90 S	4	40		
	35	0,85	23,2	1,7	MR	V	80 - 19 × 200	80 C	4	40		
	35	0,85	23,2	2	MR	V	81 - 19 × 200	80 C	4	40		
	35	0,85	23,2	1,7	MR	V	80 - 24 × 200	90 S	4	40		
	35	0,85	23,2	2	MR	V	81 - 24 × 200	90 S	4	40		
0,88	36	0,87	23	2,12	MR	V	80 - 24 × 200	90 L	6	25		
	43,1	0,89	19,8	0,75	MR	IV	50 - 19 × 200	80 C	4	32,5		
	0,76	43,8	0,83	18,2	0,67	MR	V	50 - 19 × 200	80 C	4	32	
	0,75	45	0,85	18	0,85	MR	V	50 - 19 × 200	90 L	6	20	
	43,8	0,91	19,8	1,25	MR	IV	63 - 24 × 200	90 S	4	32		
	43,8	0,91	19,8	1,5	MR	IV	64 - 24 × 200	90 S	4	32		
	43,8	0,85	18,6	1,12	MR	V	63 - 19 × 200	80 C	4	32		
	43,8	0,85	18,6	1,32	MR	V	64 - 19 × 200	80 C	4	32		
	43,8	0,85	18,6	1,12	MR	V	63 - 24 × 200	90 S	4	32		
	43,8	0,85	18,6	1,32	MR	V	64 - 24 × 200	90 S	4	32		
0,84	45	0,9	19,2	1,4	MR	V	64 - 24 × 200	90 L	6	20		
	43,8	0,92	20,1	2,36	MR	IV	80 - 24 × 200	90 S	4	32		
	43,8	0,92	20,1	2,8	MR	IV	81 - 24 × 20					



$P_1$ kW	$n_2$ min <sup>-1</sup>	$P_2$ kW	$M_2$ daN m	$f_s$	Riduttore - Motore Gear reducer - Motor	$i$			
1)									
2)									
1,1	0,92	0,88	12	1,06	MR V 50 - 19 × 200	90 S * 4	20		
		0,93	12,7	1,5	MR V 63 - 19 × 200	80 C 4	20		
		0,93	12,7	1,8	MR V 64 - 19 × 200	80 C 4	20		
		0,93	12,7	1,5	MR V 63 - 24 × 200	90 S 4	20		
		0,93	12,7	1,8	MR V 64 - 24 × 200	90 S 4	20		
		0,93	12,9	1,7	MR V 63 - 24 × 200	90 L 6	13		
		0,93	12,9	2	MR V 64 - 24 × 200	90 L 6	13		
		0,77	87,5	0,91	10	0,67	MR V 40 - 14 × 160	80 C * 4	16
				0,93	10,1	1,18	MR V 50 - 19 × 200	80 C 4	16
				0,93	10,1	1,18	MR V 50 - 19 × 200	90 S * 4	16
				0,94	10,3	1,9	MR V 63 - 19 × 200	80 C 4	16
				0,94	10,3	1,9	MR V 63 - 24 × 200	90 S 4	16
				0,93	8,3	0,75	MR V 40 - 14 × 160	80 C * 4	13
		0,84	108	0,94	8,4	1,32	MR V 50 - 19 × 200	80 C 4	13
				0,94	8,4	1,32	MR V 50 - 19 × 200	90 S * 4	13
				0,95	8,5	2,24	MR V 63 - 24 × 200	90 S 4	13
				0,95	6,5	0,9	MR V 40 - 14 × 160	80 C * 4	10
		0,93	140	0,96	6,5	1,6	MR V 50 - 19 × 200	80 C 4	10
				0,96	6,5	1,6	MR V 50 - 19 × 200	90 S * 4	10
				0,98	6,7	2,8	MR V 63 - 24 × 200	90 S 4	10
				0,95	5,2	0,95	MR V 40 - 14 × 160	80 B * 2	16
				0,96	5,2	1,7	MR V 50 - 19 × 200	80 B 2	16
				0,97	5,3	2,8	MR V 63 - 19 × 200	80 B 2	16
				0,98	4,66	1,12	MR V 40 - 14 × 160	80 C * 4	7
				0,98	4,69	2	MR V 50 - 19 × 200	80 C 4	7
		1,5	2,91	0,95	311	0,71	MR 2IV 125 - 24 × 200	90 L 4	481
				0,95	311	0,8	MR 2IV 126 - 24 × 200	90 L 4	481
				1	262	0,9	MR 2IV 125 - 24 × 200	90 L 4	385
				1	262	1,06	MR 2IV 126 - 24 × 200	90 L 4	385
				0,94	243	0,67	MR IV 125 - 24 × 200	90 LC 6	243
				0,94	243	0,8	MR IV 126 - 24 × 200	90 LC 6	243
				0,98	261	1,25	MR IV 160 - 28 × 250	100 LA 6	252
				0,98	261	1,4	MR IV 161 - 28 × 250	100 LA 6	252
				1,02	216	1,06	MR 2IV 125 - 24 × 200	90 L 4	312
				1,02	216	1,25	MR 2IV 126 - 24 × 200	90 L 4	312
				0,97	202	0,8	MR IV 125 - 28 × 250	100 LA 6	197
				0,97	202	0,9	MR IV 126 - 28 × 250	100 LA 6	197
				1	204	0,9	MR IV 125 - 24 × 200	90 LC 6	193
				1	204	1,06	MR IV 126 - 24 × 200	90 LC 6	193
				1,03	218	1,6	MR IV 160 - 28 × 250	100 LA 6	200
				1,03	218	1,9	MR IV 161 - 28 × 250	100 LA 6	200
				1,01	178	0,75	MR 2IV 100 - 24 × 200	90 L 4	258
				1,01	174	1,12	MR 2IV 125 - 24 × 200	90 L 4	254
				1,01	174	1,32	MR 2IV 126 - 24 × 200	90 L 4	254
				1,03	180	1,25	MR 2IV 125 - 28 × 250	100 LA 6	165
		0,99	164	0,95	MR IV 125 - 24 × 200	90 L 4	243		
		0,99	164	1,06	MR IV 126 - 24 × 200	90 L 4	243		
		1,02	169	1,06	MR IV 125 - 28 × 250	100 LA 6	156		
1,02	169	1,18	MR IV 126 - 28 × 250	100 LA 6	156				
1,03	168	1,18	MR IV 125 - 24 × 200	90 LC 6	154				
1,03	168	1,4	MR IV 126 - 24 × 200	90 LC 6	154				
1,07	181	2,24	MR IV 160 - 28 × 250	100 LA 6	160				
1,07	181	2,65	MR IV 161 - 28 × 250	100 LA 6	160				
1,05	145	0,95	MR 2IV 100 - 24 × 200	90 L 4	202				
1,01	131	0,71	MR IV 100 - 19 × 200	90 L * 4	190				
1,01	136	0,71	MR IV 100 - 24 × 200	90 LC 6	127				
1,06	146	1,5	MR 2IV 125 - 24 × 200	90 L 4	203				
1,06	146	1,7	MR 2IV 126 - 24 × 200	90 L 4	203				
1,04	137	1,18	MR IV 125 - 24 × 200	90 L 4	193				
1,04	137	1,4	MR IV 126 - 24 × 200	90 L 4	193				
1,05	139	1,32	MR IV 125 - 28 × 250	100 LA 6	125				
1,05	139	1,6	MR IV 126 - 28 × 250	100 LA 6	125				

$P_1$ kW	$n_2$ min <sup>-1</sup>	$P_2$ kW	$M_2$ daN m	$f_s$	Riduttore - Motore Gear reducer - Motor	$i$			
1)									
2)									
1,5	7,2	1,05	139	1,32	MR IV 125 - 24 × 200	90 LC 6	125		
		1,05	139	1,6	MR IV 126 - 24 × 200	90 LC 6	125		
		1,09	146	2,65	MR IV 160 - 28 × 250	100 LA 6	127		
		1,05	116	1,06	MR 2IV 100 - 24 × 200	90 L 4	162		
		1,06	110	1	MR IV 100 - 19 × 200	90 L * 4	152		
		1,11	110	0,75	MR IV 100 - 24 × 200	90 L 4	160		
		1,04	110	0,85	MR IV 100 - 28 × 250	100 LA 6	100		
		1,15	125	1,8	MR 2IV 126 - 24 × 200	90 L 4	159		
		1,07	113	1,6	MR IV 125 - 24 × 200	90 L 4	154		
		1,07	113	1,9	MR IV 126 - 24 × 200	90 L 4	154		
		1,09	116	1,8	MR IV 125 - 24 × 200	90 LC 6	100		
		1,09	116	2,12	MR IV 126 - 24 × 200	90 LC 6	100		
		1,05	11,3	1,05	89	0,71	MR IV 81 - 24 × 200	90 LC 6	80
				1,09	94	1,4	MR 2IV 100 - 24 × 200	90 L 4	127
				1,09	90	1,32	MR IV 100 - 19 × 200	90 L * 4	122
				1,06	92	0,95	MR IV 100 - 24 × 200	90 L 4	127
				1,08	92	1,12	MR IV 100 - 28 × 250	100 LA 6	80
				1,09	94	1,25	MR IV 100 - 24 × 200	90 LC 6	81,2
				1,09	93	1,9	MR IV 125 - 24 × 200	90 L 4	125
				1,11	96	2,12	MR IV 125 - 28 × 250	100 LA 6	81,1
				1,07	74	0,67	MR IV 80 - 19 × 200	90 L * 4	102
				1,07	74	0,8	MR IV 81 - 19 × 200	90 L * 4	102
				1,05	71	0,71	MR IV 81 - 24 × 200	90 L 4	100
				1,08	74	0,75	MR IV 80 - 24 × 200	90 LC 6	64
				1,08	74	0,9	MR IV 81 - 24 × 200	90 LC 6	64
				1,18	81	1,4	MR 2IV 100 - 24 × 200	90 L 4	102
				1,11	77	1,5	MR IV 100 - 19 × 200	90 L * 4	102
				1,1	76	1,32	MR IV 100 - 24 × 200	90 L 4	102
				1,11	75	1,5	MR IV 100 - 28 × 250	100 LA 6	64
				1,13	76	1,6	MR IV 100 - 24 × 200	90 LC 6	63,5
				1,06	71	1,06	MR V 100 - 28 × 250	100 LA 6	63
				1,06	71	1,06	MR V 100 - 24 × 200	90 LC 6	63
		1,14	77	2,5	MR IV 125 - 24 × 200	90 L 4	104		
		1,09	73	1,7	MR V 125 - 28 × 250	100 LA 6	63		
		1,09	73	2	MR V 126 - 28 × 250	100 LA 6	63		
		0,96	17,2	1,1	61	0,85	MR IV 80 - 19 × 200	90 L * 4	81,2
				1,09	60	0,8	MR IV 80 - 24 × 200	90 L 4	80
				1,1	61	1	MR IV 81 - 19 × 200	90 L * 4	81,2
				1,09	60	0,95	MR IV 81 - 24 × 200	90 L 4	80
				1,12	60	0,95	MR IV 80 - 24 × 200	90 LC 6	50
				1,12	60	1,18	MR IV 81 - 24 × 200	90 LC 6	50
				1,07	57	0,71	MR V 80 - 28 × 250	100 LA 6	50
				1,07	57	0,85	MR V 81 - 28 × 250	100 LA 6	50
				1,07	57	0,71	MR V 80 - 24 × 200	90 LC 6	50
				1,07	57	0,85	MR V 81 - 24 × 200	90 LC 6	50
				1,15	62	1,9	MR IV 100 - 19 × 200	90 L * 4	79,5
				1,13	63	1,7	MR IV 100 - 24 × 200	90 L 4	81,2
				1,15	61	1,9	MR IV 100 - 28 × 250	100 LA 6	50
1,11	59			1,32	MR V 100 - 28 × 250	100 LA 6	50		
1,11	59			1,32	MR V 100 - 24 × 200	90 LC 6	50		
1,14	60			2,24	MR V 125 - 28 × 250	100 LA 6	50		
0,95	28			1,14	49,4	1,12	MR IV 80 - 19 × 200	90 L * 4	63,5
				1,13	49,2	1	MR IV 80 - 24 × 200	90 L 4	64
				1,14	49,4	1,32	MR IV 81 - 19 × 200	90 L * 4	63,5
				1,13	49,2	1,18	MR IV 81 - 24 × 200	90 L 4	64
		1,07	46,1	0,75	MR V 80 - 24 × 200	90 L 4	63		
		1,07	46,1	0,85	MR V 81 - 24 × 200	90 L 4	63		
		1,11	47,3	0,95	MR V 80 - 28 × 250	100 LA 6	40		
		1,11	47,3	1,12	MR V 81 - 28 × 250	100 LA 6	40		
		1,11	47,3	0,95	MR V 80 - 24 × 200	90 LC 6	40		
		1,11	47,3	1,12	MR V 81 - 24 × 200	90 LC 6	40		
		1,17	51	2,12	MR IV 100 - 24 × 200	90 L 4	63,5		
		1,11	47,8	1,4	MR V 100 - 24 × 200	90 L 4	63		
0,95	28	1,15	48,8	1,8	MR V 100 - 28 × 250	100 LA 6	40		
		1,15	48,8	1,8	MR V 100 - 24 × 200	90 LC 6	40		
		1,13	38,7	0,71	MR IV 63 - 24 × 200	90 L 4	50		
		1,13	38,7	0,85	MR IV 64 - 24 × 200	90 L 4	50		
		1,12	38	0,75	MR V 64 - 24 × 200	90 LC 6	32		
		1,16	39,6	1,32	MR IV 80 - 24 × 200	90 L 4	50		
		1,16	39,6	1,6	MR IV 81 - 24 × 200	90 L 4	50		
		1,12	38,3	0,95	MR V 80 - 24 × 200	90 L 4	50		
		1,12	38,3	1,12	MR V 81 - 24 × 200	90 L 4	50		

Values in red state nominal thermal power  $P_{Tn}$  (ambient temperature 40 °C, continuous duty, see ch. 3.2).

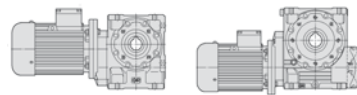
Motor (cat.TX) with efficiency value not according to IE3 class (IEC 60034-30).

Nominal power and nameplate data refer to intermittent periodic duty S3 70%.

1) Powers valid for continuous duty S1; increase possible for S2... S10 (see ch. 2b) in which case  $P_2$ ,  $M_2$  increase and  $f_s$  decreases proportionately.

2) For complete designation when ordering see ch. 3.1.

\* Mounting position **B5R**; available also for mounting position **B5** (see table ch. 2b).



$P_1$ kW 1)	$n_2$ min <sup>-1</sup>	$P_2$ kW	$M_2$ daN m	$f_s$	Riduttore - Motore Gear reducer - Motor 2)	$i$			
1.5	28,1	1,15	39	1,18	MR V 80 - 28 × 250	100 LA 6	32		
	28,1	1,15	39	1,4	MR V 81 - 28 × 250	100 LA 6	32		
	28,1	1,15	39	1,18	MR V 80 - 24 × 200	90 LC 6	32		
	28,1	1,15	39	1,4	MR V 81 - 24 × 200	90 LC 6	32		
	27,6	1,24	43	2,36	MR IV 100 - 24 × 200	90 L 4	50,8		
	28	1,15	39,4	1,8	MR V 100 - 24 × 200	90 L 4	50		
	1,24	35	1,22	33,2	0,71	MR IV 63 - 24 × 200	90 L 4	40	
		35	1,22	33,2	0,85	MR IV 64 - 24 × 200	90 L 4	40	
		1,08	35	1,14	31	0,67	MR V 63 - 24 × 200	90 L 4	40
		1,08	35	1,14	31	0,8	MR V 64 - 24 × 200	90 L 4	40
1,06		36	1,16	30,7	0,85	MR V 63 - 24 × 200	100 LA * 6	25	
1,06		36	1,16	30,7	1	MR V 64 - 24 × 200	100 LA * 6	25	
1,06		36	1,16	30,7	0,85	MR V 63 - 24 × 200	90 LC 6	25	
1,06		36	1,16	30,7	1	MR V 64 - 24 × 200	90 LC 6	25	
34,5		1,24	34,5	1,5	MR IV 80 - 19 × 200	90 L * 4	40,6		
35		1,24	33,7	1,32	MR IV 80 - 24 × 200	90 L 4	40		
1,17	34,5	1,24	34,5	1,8	MR IV 81 - 19 × 200	90 L * 4	40,6		
	35	1,24	33,7	1,6	MR IV 81 - 24 × 200	90 L 4	40		
	35	1,16	31,7	1,25	MR V 80 - 24 × 200	90 L 4	40		
	35	1,16	31,7	1,5	MR V 81 - 24 × 200	90 L 4	40		
	36	1,18	31,4	1,6	MR V 80 - 28 × 250	100 LA 6	25		
	36	1,18	31,4	1,9	MR V 81 - 28 × 250	100 LA 6	25		
	36	1,18	31,4	1,6	MR V 80 - 24 × 200	90 LC 6	25		
	36	1,18	31,4	1,9	MR V 81 - 24 × 200	90 LC 6	25		
	34,5	1,26	34,9	2,8	MR IV 100 - 24 × 200	90 L 4	40,6		
	35	1,19	32,4	2,36	MR V 100 - 24 × 200	90 L 4	40		
0,84	43,8	1,24	27	0,9	MR IV 63 - 24 × 200	90 L 4	32		
	43,8	1,24	27	1,12	MR IV 64 - 24 × 200	90 L 4	32		
	1,17	43,8	1,16	25,4	0,85	MR V 63 - 24 × 200	90 L 4	32	
	1,17	43,8	1,16	25,4	1	MR V 64 - 24 × 200	90 L 4	32	
	43,8	1,26	27,5	1,7	MR IV 80 - 24 × 200	90 L 4	32		
	43,8	1,26	27,5	2,12	MR IV 81 - 24 × 200	90 L 4	32		
	43,8	1,19	26	1,6	MR V 80 - 24 × 200	90 L 4	32		
	43,8	1,19	26	1,9	MR V 81 - 24 × 200	90 L 4	32		
	56	1,17	20	0,67	MR V 50 - 19 × 200	90 L * 4	25		
	56	1,2	20,4	1,06	MR V 63 - 24 × 200	90 L 4	25		
0,92	56	1,2	20,4	1,25	MR V 64 - 24 × 200	90 L 4	25		
	56,3	1,25	21,3	1,12	MR V 63 - 24 × 200	100 LA * 6	16		
	56	1,22	20,8	2	MR V 80 - 24 × 200	90 L 4	25		
	56	1,22	20,8	2,36	MR V 81 - 24 × 200	90 L 4	25		
	70	1,2	16,3	0,8	MR V 50 - 19 × 200	90 L * 4	20		
	70	1,27	17,3	1,12	MR V 63 - 24 × 200	90 L 4	20		
	70	1,27	17,3	1,32	MR V 64 - 24 × 200	90 L 4	20		
	69,2	1,27	17,6	1,5	MR V 64 - 24 × 200	100 LA * 6	13		
	69,2	1,27	17,6	1,25	MR V 63 - 24 × 200	90 LC 6	13		
	69,2	1,27	17,6	1,5	MR V 64 - 24 × 200	90 LC 6	13		
1,18	70	1,28	17,5	2,12	MR V 80 - 24 × 200	90 L 4	20		
	70	1,28	17,5	2,5	MR V 81 - 24 × 200	90 L 4	20		
	87,5	1,26	13,8	0,85	MR V 50 - 19 × 200	90 L * 4	16		
	87,5	1,28	14	1,4	MR V 63 - 24 × 200	90 L 4	16		
	87,5	1,28	14	1,7	MR V 64 - 24 × 200	90 L 4	16		
	87,5	1,3	14,2	2,65	MR V 80 - 24 × 200	90 L 4	16		
	87,5	1,3	14,2	3,15	MR V 81 - 24 × 200	90 L 4	16		
	108	1,29	11,4	1	MR V 50 - 19 × 200	90 L * 4	13		
	108	1,3	11,5	1,6	MR V 63 - 24 × 200	90 L 4	13		
	108	1,3	11,5	1,9	MR V 64 - 24 × 200	90 L 4	13		
0,89	140	1,23	8,4	0,67	MR V 40 - 14 × 160	80 C * 2	20		
	140	1,3	8,9	1,18	MR V 50 - 19 × 200	90 L * 4	10		
	140	1,33	9,1	2	MR V 63 - 24 × 200	90 L 4	10		
	175	1,29	7	0,71	MR V 40 - 14 × 160	80 C * 2	16		
	175	1,3	7,1	1,25	MR V 50 - 19 × 200	80 C 2	16		
	175	1,3	7,1	1,32	MR V 50 - 19 × 200	90 S * 2	16		
	175	1,32	7,2	2,12	MR V 63 - 19 × 200	80 C 2	16		
	175	1,32	7,2	2,12	MR V 63 - 24 × 200	90 S 2	16		
	200	1,34	6,4	1,5	MR V 50 - 19 × 200	90 L * 4	7		
	200	1,36	6,5	2,5	MR V 63 - 24 × 200	90 L 4	7		
1,25	215	1,31	5,8	0,85	MR V 40 - 14 × 160	80 C * 2	13		
	215	1,32	5,9	1,5	MR V 50 - 19 × 200	80 C 2	13		
	215	1,32	5,9	1,5	MR V 50 - 19 × 200	90 S * 2	13		
	215	1,33	5,9	2,36	MR V 63 - 19 × 200	80 C 2	13		
	215	1,33	5,9	2,36	MR V 63 - 24 × 200	90 S 2	13		

$P_1$ kW 1)	$n_2$ min <sup>-1</sup>	$P_2$ kW	$M_2$ daN m	$f_s$	Riduttore - Motore Gear reducer - Motor 2)	$i$		
1.5	280	1,32	4,52	1	MR V 40 - 14 × 160	80 C * 2	10	
	280	1,33	4,55	1,7	MR V 50 - 19 × 200	80 C 2	10	
	280	1,33	4,55	1,7	MR V 50 - 19 × 200	90 S * 2	10	
	400	1,36	3,24	1,25	MR V 40 - 14 × 160	80 C * 2	7	
	400	1,36	3,25	2,24	MR V 50 - 19 × 200	80 C 2	7	
	400	1,36	3,25	2,24	MR V 50 - 19 × 200	90 S * 2	7	
	1.85	3,64	1,23	323	0,75	MR 2IV 125 - 24 × 200	90 LB 4	385
		3,64	1,23	323	0,85	MR 2IV 126 - 24 × 200	90 LB 4	385
		3,57	1,2	322	1	MR IV 160 - 28 × 250	100 LB 6	252
		3,57	1,2	322	1,18	MR IV 161 - 28 × 250	100 LB 6	252
3,57		1,24	332	1,8	MR IV 200 - 28 × 250	100 LB 6	252	
4,49		1,25	267	0,85	MR 2IV 125 - 24 × 200	90 LB 4	312	
4,49		1,25	267	1	MR 2IV 126 - 24 × 200	90 LB 4	312	
4,57		1,19	250	0,75	MR IV 126 - 28 × 250	100 LB 6	197	
4,5		1,27	269	1,32	MR IV 160 - 28 × 250	100 LB 6	200	
4,5		1,27	269	1,5	MR IV 161 - 28 × 250	100 LB 6	200	
1,13	5,52	1,24	215	0,9	MR 2IV 125 - 24 × 200	90 LB 4	254	
	5,52	1,24	215	1,06	MR 2IV 126 - 24 × 200	90 LB 4	254	
	5,47	1,27	222	1	MR 2IV 125 - 28 × 250	100 LB 6	165	
	5,47	1,27	222	1,18	MR 2IV 126 - 28 × 250	100 LB 6	165	
	5,76	1,22	203	0,75	MR IV 125 - 24 × 200	90 LB 4	243	
	5,76	1,22	203	0,85	MR IV 126 - 24 × 200	90 LB 4	243	
	5,76	1,26	209	0,85	MR IV 125 - 28 × 250	100 LB 6	156	
	5,76	1,26	209	0,95	MR IV 126 - 28 × 250	100 LB 6	156	
	5,63	1,31	223	1,8	MR IV 160 - 28 × 250	100 LB 6	160	
	5,63	1,31	223	2,12	MR IV 161 - 28 × 250	100 LB 6	160	
0,89	6,93	1,3	179	0,75	MR 2IV 100 - 24 × 200	90 LB 4	202	
	6,9	1,3	180	1,18	MR 2IV 125 - 24 × 200	90 LB 4	203	
	6,9	1,3	180	1,4	MR 2IV 126 - 24 × 200	90 LB 4	203	
	7,26	1,28	169	1	MR IV 125 - 24 × 200	90 LB 4	193	
	7,26	1,28	169	1,18	MR IV 126 - 24 × 200	90 LB 4	193	
	7,2	1,29	172	1,12	MR IV 125 - 28 × 250	100 LB 6	125	
	7,2	1,29	172	1,32	MR IV 126 - 28 × 250	100 LB 6	125	
	7,09	1,34	181	2,12	MR IV 160 - 28 × 250	100 LB 6	127	
	7,09	1,34	181	2,5	MR IV 161 - 28 × 250	100 LB 6	127	
	8,62	1,29	143	0,85	MR 2IV 100 - 24 × 200	90 LB 4	162	
1,13	9,21	1,31	135	0,8	MR IV 100 - 19 × 200	90 LB * 4	152	
	9	1,28	136	0,67	MR IV 100 - 28 × 250	100 LB 6	100	
	8,83	1,42	154	1,25	MR 2IV 125 - 24 × 200	90 LB 4	159	
	8,83	1,42	154	1,5	MR 2IV 126 - 24 × 200	90 LB 4	159	
	9,07	1,32	139	1,32	MR IV 125 - 24 × 200	90 LB 4	154	
	9,07	1,32	139	1,6	MR IV 126 - 24 × 200	90 LB 4	154	
	11	1,34	116	1,12	MR 2IV 100 - 24 × 200	90 LB 4	127	
	11,5	1,34	111	1,06	MR IV 100 - 19 × 200	90 LB * 4	122	
	11	1,3	113	0,8	MR IV 100 - 24 × 200	90 LB 4	127	
	11,3	1,33	113	0,9	MR IV 100 - 28 × 250	100 LB 6	80	
1,13	11,2	1,35	115	1,5	MR IV 125 - 24 × 200	90 LB 4	125	
	11,2	1,35	115	1,8	MR IV 126 - 24 × 200	90 LB 4	125	
	11,1	1,37	118	1,7	MR IV 125 - 28 × 250	100 LB 6	81,1	
	11,1	1,37	118	2	MR IV 126 - 28 × 250	100 LB 6	81,1	
	14,1	1,34	91	0,71	MR IV 81 - 24 × 200	100 LB * 6	64	
	13,8	1,45	101	1,12	MR 2IV 100 - 24 × 200	90 LB 4	102	
	13,8	1,37	95	1,18	MR IV 100 - 19 × 200	90 LB * 4	102	
	13,8	1,36	94	1,06	MR IV 100 - 24 × 200	90 LB 4	102	
	14,1	1,37	93	1,25	MR IV 100 - 28 × 250	100 LB 6	64	
	14,3	1,31	87	0,85	MR V 100 - 28 × 250	100 LB 6	63	
1,22	14	1,4	96	2	MR IV 125 - 24 × 200	90 LB 4	100	
	14,3	1,35	90	1,4	MR V 125 - 28 × 250	100 LB 6	63	
	14,3	1,35	90	1,6	MR V 126 - 28 × 250	100 LB 6	63	
	17,2	1,36	75	0,71	MR IV 80 - 19 × 200	90 LB * 4	81,2	
	17,2	1,36	75	0,85	MR IV 81 - 19 × 200	90 LB * 4	81,2	
	1,23	17,5	1,35	73	0,75	MR IV 81 - 24 × 200	90 LB 4	80
	1,24	18	1,38	73	0,8	MR IV 80 - 24 × 200	100 LB * 6	50
	1,24	18	1,38	73	0,95	MR IV 81 - 24 × 200	100 LB * 6	50
	1,37	18	1,32	70	0,71	MR V 81 - 28 × 250	100 LB 6	50
	17,6	1,42	77	1,5	MR IV 100 - 19 × 200	90 LB * 4	79,5	
1,25	17,2	1,39	77	1,4	MR IV 100 - 24 × 200	90 LB 4	81,2	
	18	1,37	73	1,12	MR V 100 - 28 × 250	100 LB 6	50	
	17,9	1,51	80	2,12	MR IV 125 - 24 × 200	90 LB 4	78,1	
	18	1,4	74	1,8	MR V 125 - 28 × 250	100 LB 6	50	

Values in red state nominal thermal power  $P_{th}$  (ambient temperature 40 °C, continuous duty, see ch. 3.2).

Motor (cat.TX) with efficiency value not according to IE3 class (IEC 60034-30).

Nominal power and nameplate data refer to intermittent periodic duty S3 70%.

1) Powers valid for continuous duty S1; increase possible for S2 ... S10 (see ch. 2b) in which case  $P_2$ ,  $M_2$  increase and  $f_s$  decreases proportionately.

2) For complete designation when ordering see ch. 3.1.

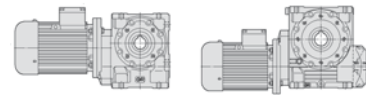
\* Mounting position **B5R** available also for mounting position **B5** (see table ch. 2b).







# Gearmotors selection tables



3.7

$P_1$ kW	$n_2$ min <sup>-1</sup>	$P_2$ kW	$M_2$ daN m	$f_s$	Riduttore - Motore Gear reducer - Motor					$i$	
					2)						
3	7,09 7	2,17 2,2	293 300	1,6 2,24	MR IV 161 - 28 x 250	112 MC 6	6	127			
					MR IV 200 - 28 x 250	112 MA 4	4	200			
	8,5	2,15	241	0,85	MR 2IV 125 - 28 x 250	112 MA 4	4	165			
	8,5	2,15	241	1	MR 2IV 126 - 28 x 250	112 MA 4	4	165			
	8,96	2,12	226	0,71	MR IV 125 - 28 x 250	112 MA 4	4	156			
	8,96	2,12	226	0,85	MR IV 126 - 28 x 250	112 MA 4	4	156			
	8,87	2,14	231	0,8	MR IV 125 - 28 x 250	112 MC 6	6	101			
	8,87	2,14	231	0,95	MR IV 126 - 28 x 250	112 MC 6	6	101			
	8,75	2,21	242	1,6	MR IV 160 - 28 x 250	112 MA 4	4	160			
	8,75	2,21	242	1,8	MR IV 161 - 28 x 250	112 MA 4	4	160			
	8,75	2,27	247	2,8	MR IV 200 - 28 x 250	112 MA 4	4	160			
	11,2	2,18	186	0,95	MR IV 125 - 28 x 250	112 MA 4	4	125			
	11,2	2,18	186	1,12	MR IV 126 - 28 x 250	112 MA 4	4	125			
	11,1	2,23	192	1,06	MR IV 125 - 28 x 250	112 MC 6	6	81,1			
	11,1	2,23	192	1,25	MR IV 126 - 28 x 250	112 MC 6	6	81,1			
	11	2,26	196	1,8	MR IV 160 - 28 x 250	112 MA 4	4	127			
	11	2,26	196	2,12	MR IV 161 - 28 x 250	112 MA 4	4	127			
	2,44	13,8	2,2	152	0,67	MR IV 100 - 24 x 200	112 MA* 4	4	102		
	2,3	14,1	2,22	151	0,75	MR IV 100 - 28 x 250	112 MC 6	6	64		
		13,8	2,23	154	1,06	MR IV 125 - 28 x 250	112 MA 4	4	101		
		13,8	2,23	154	1,32	MR IV 126 - 28 x 250	112 MA 4	4	101		
		14,3	2,18	146	0,85	MR V 125 - 28 x 250	112 MC 6	6	63		
		14,3	2,18	146	1	MR V 126 - 28 x 250	112 MC 6	6	63		
		14,3	2,18	146	0,85	MR V 125 - 38 x 300	132 S 6	6	63		
		14,3	2,18	146	1	MR V 126 - 38 x 300	132 S 6	6	63		
		13,8	2,33	161	2,24	MR IV 160 - 28 x 250	112 MA 4	4	102		
		13,8	2,33	161	2,65	MR IV 161 - 28 x 250	112 MA 4	4	102		
		14,3	2,24	150	1,6	MR V 160 - 28 x 250	112 MC 6	6	63		
		14,3	2,24	150	1,9	MR V 161 - 28 x 250	112 MC 6	6	63		
		14,3	2,24	150	1,6	MR V 160 - 38 x 300	132 S 6	6	63		
		14,3	2,24	150	1,9	MR V 161 - 38 x 300	132 S 6	6	63		
		17,5	2,25	123	0,8	MR IV 100 - 28 x 250	112 MA 4	4	80		
		18	2,3	122	0,95	MR IV 100 - 28 x 250	112 MC 6	6	50		
		18	2,22	118	0,67	MR V 100 - 28 x 250	112 MC 6	6	50		
		17,3	2,32	128	1,4	MR IV 125 - 28 x 250	112 MA 4	4	81,1		
		17,3	2,32	128	1,7	MR IV 126 - 28 x 250	112 MA 4	4	81,1		
		18	2,27	120	1,12	MR V 125 - 28 x 250	112 MC 6	6	50		
		18	2,27	120	1,32	MR V 126 - 28 x 250	112 MC 6	6	50		
		18	2,27	120	1,12	MR V 125 - 38 x 300	132 S 6	6	50		
		18	2,27	120	1,32	MR V 126 - 38 x 300	132 S 6	6	50		
		17,6	2,48	134	2,36	MR IV 160 - 28 x 250	112 MA 4	4	79,3		
		17,6	2,48	134	2,8	MR IV 161 - 28 x 250	112 MA 4	4	79,3		
		18	2,33	123	2,12	MR V 160 - 28 x 250	112 MC 6	6	50		
		18	2,33	123	2,5	MR V 161 - 28 x 250	112 MC 6	6	50		
		18	2,33	123	2,12	MR V 160 - 38 x 300	132 S 6	6	50		
		21,9	2,31	101	1	MR IV 100 - 28 x 250	112 MA 4	4	64		
		22,2	2,22	96	0,71	MR V 100 - 28 x 250	112 MA 4	4	63		
	22,5	2,3	98	0,9	MR V 100 - 28 x 250	112 MC 6	6	40			
	22,1	2,48	107	1,5	MR IV 125 - 28 x 250	112 MA 4	4	63,4			
	22,1	2,48	107	1,8	MR IV 126 - 28 x 250	112 MA 4	4	63,4			
	22,2	2,5	108	1,7	MR IV 125 - 28 x 250	112 MC 6	6	40,6			
	22,2	2,5	108	2	MR IV 126 - 28 x 250	112 MC 6	6	40,6			
	22,2	2,27	98	1,12	MR V 125 - 28 x 250	112 MA 4	4	63			
	22,2	2,27	98	1,32	MR V 126 - 28 x 250	112 MA 4	4	63			
	22,5	2,32	99	1,5	MR V 125 - 28 x 250	112 MC 6	6	40			
	22,5	2,32	99	1,8	MR V 126 - 28 x 250	112 MC 6	6	40			
	22,5	2,32	99	1,5	MR V 125 - 38 x 300	132 S 6	6	40			
	22,5	2,32	99	1,8	MR V 126 - 38 x 300	132 S 6	6	40			
1,49	28	2,32	79	0,67	MR IV 80 - 24 x 200	112 MA* 4	4	50			
1,49	28	2,32	79	0,8	MR IV 81 - 24 x 200	112 MA* 4	4	50			
1,66	28,1	2,3	78	0,71	MR V 81 - 28 x 250	112 MC 6	6	32			
	28	2,38	81	1,25	MR IV 100 - 28 x 250	112 MA 4	4	50			
	28	2,31	79	0,9	MR V 100 - 28 x 250	112 MA 4	4	50			
	28,1	2,35	80	1,18	MR V 100 - 28 x 250	112 MC 6	6	32			
	28,1	2,35	80	1,18	MR V 100 - 38 x 300	132 S 6	6	32			
	27,6	2,51	87	1,9	MR IV 125 - 28 x 250	112 MA 4	4	50,7			
	28	2,35	80	1,5	MR V 125 - 28 x 250	112 MA 4	4	50			
	28	2,35	80	1,8	MR V 126 - 28 x 250	112 MA 4	4	50			
	28,1	2,4	82	1,9	MR V 125 - 28 x 250	112 MC 6	6	32			
	28,1	2,4	82	1,9	MR V 125 - 38 x 300	132 S 6	6	32			
1,91	35	2,47	67	0,67	MR IV 80 - 24 x 200	112 MA* 4	4	40			
1,91	35	2,47	67	0,8	MR IV 81 - 24 x 200	112 MA* 4	4	40			

Values in red state nominal thermal power  $P_{Tn}$  (ambient temperature 40 °C, continuous duty, see ch. 3.2).

Motor (cat.TX) with efficiency value not according to IE3 class (IEC 60034-30).

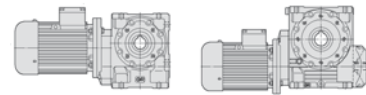
Nominal power and nameplate data refer to intermittent periodic duty S3 70%.

1) Powers valid for continuous duty S1; increase possible for S2... S10 (see ch. 2b) in which case  $P_2$ ,  $M_2$  increase and  $f_s$  decreases proportionately.

2) For complete designation when ordering see ch. 3.1.

\* Mounting position **B5R**, available also for mounting position **B5** (see table ch. 2b).





$P_1$ kW	$n_2$ $\text{min}^{-1}$	$P_2$ kW	$M_2$ daN m	$f_s$	Riduttore - Motore Gear reducer - Motor				$i$		
1)					2)						
5.5	22.2	4,17	179	0,75	<b>MR</b>	<b>V 126</b>	<b>- 38 x 250</b>	<b>112 MC 4</b>	63		
	22.2	4,17	179	0,75	<b>MR</b>	<b>V 126</b>	<b>- 38 x 300</b>	<b>132 S 4</b>	63		
	22.5	4,26	181	0,8	<b>MR</b>	<b>V 125</b>	<b>- 38 x 300</b>	<b>132 MB 6</b>	40		
	3.5	27.6	4,61	159	1,06	<b>MR</b>	<b>IV 125</b>	<b>- 28 x 250</b>	<b>112 MC 4</b>	50,7	
		7.5	3.76	5,2	1329	0,85	<b>MR</b>	<b>IV 250</b>	<b>- 38 x 300</b>	<b>132 MC 6</b>	239

Values in red state nominal thermal power  $P_{th}$  (ambient temperature 40 °C, continuous duty, see ch. 3.2).

Motor (cat.TX) with efficiency value not according to IE3 class (IEC 60034-30).

Nominal power and nameplate data refer to intermittent periodic duty S3 70%.

1) Powers valid for continuous duty S1; **increase** possible for S2... S10 (see ch. 2b) in which case  $P_2$ ,  $M_2$  increase and  $f_s$  decreases proportionately.

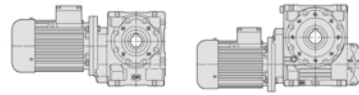
2) For complete designation when ordering see ch. 3.1.

\* Mounting position **B5R**, available also for mounting position **B5** (see table ch. 2b).





# Gearmotors selection tables



## 3.7

$P_1$ kW	$n_2$ min <sup>-1</sup>	$P_2$ kW	$M_2$ daN m	$f_s$	Riduttore - Motore Gear reducer - Motor	$i$
15	22,2 22,5	12,2 12,4	523 525	1,4 1,8	MR V 250 - 42 × 350 160 L 4 MR V 250 - 48 × 350 180 L 6	63 40
10 10,3 9,1 9,1	28 28 28,1 28,1 28 28 28,1 27,4 28	12,7 12 12,2 12,2 12,9 12,2 12,5 13,1 12,4	434 410 415 415 440 417 423 456 425	0,75 0,67 0,71 0,8 1,32 1,06 1,32 2,5 1,9	MR IV 161 - 42 × 350 160 L 4 MR V 161 - 42 × 350 160 L 4 MR V 160 - 48 × 350 180 L 6 MR V 161 - 48 × 350 180 L 6 MR IV 200 - 42 × 350 160 L 4 MR V 200 - 42 × 350 160 L 4 MR V 200 - 48 × 350 180 L 6 MR IV 250 - 42 × 350 160 L 4 MR V 250 - 42 × 350 160 L 4	50 50 32 32 50 50 32 51,1 50
10,8 10,8 11,4 11,4	35 35 35 35	12,9 12,9 12,3 12,3	352 352 335 335	0,8 1 0,71 0,85	MR IV 160 - 42 × 350 160 L 4 MR IV 161 - 42 × 350 160 L 4 MR V 160 - 42 × 350 160 L 4 MR V 161 - 42 × 350 160 L 4	40 40 40 40
11,8 11,8 12,5 12,5	35 36 34,2 35	13,1 13,4 12,6 12,6	285 285 344 344	1 1,18 2,36 2,36	MR IV 161 - 42 × 350 160 L 4 MR IV 161 - 42 × 350 160 L 4 MR IV 160 - 42 × 350 160 L 4 MR IV 161 - 42 × 350 160 L 4	32 32 40 40
10,4	56 56 56 56,3 56,3 56 56,3	12,9 13,1 13,1 13,2 13,2 13,2 13,4	221 223 223 224 224 225 228	0,67 1 1,18 1,18 1,4 1,9 2,12	MR V 126 - 38 × 300 160 L 4 MR V 160 - 42 × 350 160 L 4 MR V 161 - 42 × 350 160 L 4 MR V 160 - 48 × 350 180 L 6 MR V 161 - 48 × 350 180 L 6 MR V 200 - 42 × 350 160 L 4 MR V 200 - 48 × 350 180 L 6	25 25 25 16 16 25 16
11,2 11,2	70 70 70 70 69,2 69,2 70	13,1 13,1 13,2 13,2 13,4 13,4 13,3	179 179 180 180 185 185 182	0,67 0,8 1,25 1,5 1,7 1,7 2,36	MR V 125 - 38 × 300 160 L 4 MR V 126 - 38 × 300 160 L 4 MR V 160 - 42 × 350 160 L 4 MR V 161 - 42 × 350 160 L 4 MR V 160 - 48 × 350 180 L 6 MR V 161 - 48 × 350 180 L 6 MR V 200 - 42 × 350 160 L 4	20 20 20 20 13 13 20
12,2 12,2	87,5 87,5 87,5 87,5	13,3 13,3 13,4 13,4	145 145 146 146	0,8 0,95 1,5 1,8	MR V 125 - 38 × 300 160 L 4 MR V 126 - 38 × 300 160 L 4 MR V 160 - 42 × 350 160 L 4 MR V 161 - 42 × 350 160 L 4	16 16 16 16
108 108 108 108	108 108 108 108	13,5 13,5 13,6 13,6	120 120 120 120	0,95 1,12 1,8 2,12	MR V 125 - 38 × 300 160 L 4 MR V 126 - 38 × 300 160 L 4 MR V 160 - 42 × 350 160 L 4 MR V 161 - 42 × 350 160 L 4	13 13 13 13
140 140 140 140	140 140 140 140	13,6 13,6 13,7 13,7	93 93 93 93	1,12 1,32 2 2,36	MR V 125 - 38 × 300 160 L 4 MR V 126 - 38 × 300 160 L 4 MR V 160 - 42 × 350 160 L 4 MR V 161 - 42 × 350 160 L 4	10 10 10 10
18,5	11 13,6 14,9	8,8 11 14,3	1556 1266 1036 974	0,8 0,9 1,06 0,9	MR IV 250 - 55 × 400 200 LR 6 MR IV 250 - 48 × 350 180 M 4 MR IV 250 - 48 × 350 180 M 4 MR V 250 - 55 × 400 200 LR 6	102 128 102 63
10,9 11,7	17,5 18 17,1 18 18	14,8 14,7 15,6 15,8 15	806 778 871 839 795	0,71 0,71 1,12 1,4 1,25	MR IV 200 - 48 × 350 180 M 4 MR V 200 - 55 × 400 200 LR 6 MR IV 250 - 48 × 350 180 M 4 MR IV 250 - 55 × 400 200 LR 6 MR V 250 - 55 × 400 200 LR 6	80 50 81,8 50 50
12,2 12,8	21,9 22,5 21,9 22,5 22,2 22,5	15,1 15 16 16 16 15	661 636 696 678 645	0,9 0,85 1,6 1,8 1,12	MR IV 200 - 48 × 350 180 M 4 MR V 200 - 55 × 400 200 LR 6 MR IV 250 - 48 × 350 180 M 4 MR IV 250 - 55 × 400 200 LR 6 MR V 250 - 48 × 350 180 L 4 MR V 250 - 48 × 350 180 L 4	64 40 63,9 40 40 63

$P_1$ kW	$n_2$ min <sup>-1</sup>	$P_2$ kW	$M_2$ daN m	$f_s$	Riduttore - Motore Gear reducer - Motor	$i$
18,5	22,5	15,2	647	1,5	MR V 250 - 55 × 400 200 LR 6	40
14,5	28 28,1 27,4 28	15,9 15,1 15,4 16,1 15,4	543 515 522 562 524	1,06 0,85 1,06 2 1,5	MR IV 200 - 48 × 350 180 M 4 MR V 200 - 48 × 350 180 M 4 MR V 200 - 55 × 400 200 LR 6 MR IV 250 - 48 × 350 180 M 4 MR V 250 - 48 × 350 180 M 4	50 50 32 51,1 50
10,8 10,8 11,4	35 35 35 35	15,9 15,9 15,2 16,1 15,4 16	434 434 413 439 419 425	0,67 0,8 0,71 1,32 1,06 1,25	MR IV 160 - 48 × 350 180 M 4 MR IV 161 - 48 × 350 180 M 4 MR V 161 - 48 × 350 180 M 4 MR IV 200 - 48 × 350 180 M 4 MR V 200 - 48 × 350 180 M 4 MR V 200 - 55 × 400 200 LR 6	40 40 40 40 40 25
11,8 11,8 12,5 12,5	36 34,2 35 43,8 43,8 43,8 43,8 43,8 45 43,8	16,5 16,5 15,5 16,1 16,1 15,5 16,1 16,1 16,2 16,2	460 460 424 352 352 337 337 359 342 345 354	2,36 1,9 0,8 0,95 0,71 0,85 1,5 1,32 1,6 2	MR IV 250 - 48 × 350 180 M 4 MR V 250 - 48 × 350 180 M 4 MR V 160 - 48 × 350 180 M 4 MR IV 161 - 48 × 350 180 M 4 MR V 160 - 48 × 350 180 M 4 MR V 161 - 48 × 350 180 M 4 MR IV 200 - 48 × 350 180 M 4 MR V 200 - 48 × 350 180 M 4 MR V 200 - 55 × 400 200 LR 6 MR V 250 - 48 × 350 180 M 4	40,9 40 32 32 32 32 32 20 32
56 56 56 56,3 56,3 56 56,3	70 70 70 70 70 70	16,1 16,1 16,3 16,5 16,5 16,3 16,3	275 275 278 281 280 223 223	0,85 1 1,5 1,8 2,8 1 1,18	MR V 160 - 48 × 350 180 M 4 MR V 161 - 48 × 350 180 M 4 MR V 200 - 48 × 350 180 M 4 MR V 200 - 55 × 400 200 LR 6 MR V 250 - 48 × 350 180 M 4 MR V 160 - 48 × 350 180 M 4 MR V 161 - 48 × 350 180 M 4	25 25 25 16 16 20 20
87,5 87,5 87,5 87,5	87,5 87,5 87,5 87,5	16,5 16,5 16,7 18,8 18,8 17,8 18 18	180 180 183 1036 998 946 786 756	1,18 1,4 2,24 0,95 1,18 1,06 0,8 0,71	MR V 160 - 48 × 350 180 M 4 MR V 161 - 48 × 350 180 M 4 MR V 200 - 48 × 350 180 M 4 MR V 160 - 48 × 350 180 M 4 MR IV 250 - 55 × 400 200 L 6 MR V 250 - 55 × 400 200 L 6 MR IV 200 - 48 × 350 180 L 4 MR V 200 - 55 × 400 200 L 6	16 16 16 81,8 50 50 64 40
108 108 108 108	108 108 108 108	16,8 16,8 16,8 16,8	149 149 149 149	1,4 1,7 2,65 1,5	MR V 160 - 48 × 350 180 M 4 MR V 161 - 48 × 350 180 M 4 MR V 200 - 48 × 350 180 M 4 MR V 250 - 48 × 350 180 L 4	13 13 13 63,9
140 140 140 140	140 140 140 140	16,9 16,9 16,9 18,9 17,9 18,3 19 19 19,2 19,2 19,2 19	115 115 115 645 612 621 668 623 644	1,6 1,9 1,9 0,9 0,71 0,9 1,7 1,25 1,32 1,2 1,2 1,25	MR V 160 - 48 × 350 180 M 4 MR V 161 - 48 × 350 180 M 4 MR IV 200 - 48 × 350 180 L 4 MR V 200 - 48 × 350 180 L 4 MR V 200 - 55 × 400 200 L 6 MR V 250 - 48 × 350 180 L 4 MR V 250 - 48 × 350 180 L 4 MR V 250 - 55 × 400 200 L 6 MR IV 200 - 48 × 350 180 L 4 MR V 200 - 48 × 350 180 L 4 MR V 200 - 55 × 400 200 L 6 MR V 250 - 48 × 350 180 L 4	10 10 10 50 50 32 51,1 50 32 50
15,7 16,2 14,5	28 28 28,1 27,4 28 28,1	18,9 17,9 18,3 19,2 18,3 19	645 612 621 668 623 644	0,9 0,71 0,9 1,7 1,25 1,32	MR IV 200 - 48 × 350 180 L 4 MR V 200 - 48 × 350 180 L 4 MR V 200 - 55 × 400 200 L 6 MR IV 250 - 48 × 350 180 L 4 MR V 250 - 48 × 350 180 L 4 MR V 250 - 55 × 400 200 L 6	50 50 32 51,1 50 32
17 17,7 18,3	35 35 36 34,2 35 36	19,2 18,3 19,1 19,6 18,5 19,3	523 499 506 547 504 513	1,12 0,9 1,06 1,9 1,6 1,8	MR IV 200 - 48 × 350 180 L 4 MR V 200 - 48 × 350 180 L 4 MR V 200 - 55 × 400 200 L 6 MR IV 250 - 48 × 350 180 L 4 MR V 250 - 48 × 350 180 L 4 MR V 250 - 55 × 400 200 L 6	40 40 25 40,9 40 25
12,5	43,8 43,8 43,8 45 43,8	18,4 19,6 18,6 19,3 19,3	401 427 406 410 421	0,71 1,25 1,12 1,32 1,7	MR V 161 - 48 × 350 180 L 4 MR IV 200 - 48 × 350 180 L 4 MR V 200 - 48 × 350 180 L 4 MR V 200 - 55 × 400 200 L 6 MR V 250 - 48 × 350 180 L 4	32 32 32 20 32

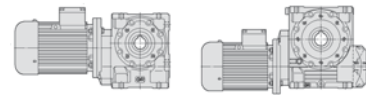
Values in red state nominal thermal power  $P_{Tn}$  (ambient temperature 40 °C, continuous duty, see ch. 3.2).

1) Powers valid for continuous duty S1; **increase** possible for S2... S10 (see ch. 2b) in which case  $P_2$ ,  $M_2$  increase and  $f_s$  decreases proportionately.

2) For complete designation when ordering see ch. 3.1.

\* Mounting position **B5R** (see table ch. 2b).





$P_1$ kW	$n_2$ min <sup>-1</sup>	$P_2$ kW	$M_2$ daN m	$f_s$	Riduttore - Motore Gear reducer - Motor	$i$	
1)					2)		
22	45	19,5	413	2,24	MR V 250 - 55 × 400 200 L	6 20	
16,1	56	19,2	327	0,71	MR V 160 - 48 × 350 180 L	4 25	
16,1	56	19,2	327	0,85	MR V 161 - 48 × 350 180 L	4 25	
	56	19,4	331	1,32	MR V 200 - 48 × 350 180 L	4 25	
	56,3	19,7	334	1,5	MR V 200 - 55 × 400 200 L	6 16	
	56	19,6	333	2,36	MR V 250 - 48 × 350 180 L	4 25	
17,4	70	19,4	265	0,85	MR V 160 - 48 × 350 180 L	4 20	
17,4	70	19,4	265	1	MR V 161 - 48 × 350 180 L	4 20	
	70	19,6	267	1,6	MR V 200 - 48 × 350 180 L	4 20	
	69,2	19,8	274	1,8	MR V 200 - 55 × 400 200 L	6 13	
	70	19,7	268	2,8	MR V 250 - 48 × 350 180 L	4 20	
	87,5	19,6	214	1	MR V 160 - 48 × 350 180 L	4 16	
	87,5	19,6	214	1,18	MR V 161 - 48 × 350 180 L	4 16	
	87,5	19,9	217	1,9	MR V 200 - 48 × 350 180 L	4 16	
	108	19,9	177	1,18	MR V 160 - 48 × 350 180 L	4 13	
	108	19,9	177	1,4	MR V 161 - 48 × 350 180 L	4 13	
	108	20	177	2,12	MR V 200 - 48 × 350 180 L	4 13	
	140	20,1	137	1,4	MR V 160 - 48 × 350 180 L	4 10	
	140	20,1	137	1,6	MR V 161 - 48 × 350 180 L	4 10	
30	14,9	13,7	24,1	1679	0,67	MR IV 250 - 55 × 400 200 L	4 102
17,3	17,5	24,4	1332	0,8	MR IV 250 - 55 × 400 200 L	4 80	
21,4	21,9	25,9	1129	1	MR IV 250 - 48 × 350 200 L	* 4 63,9	
22,2	21,9	25,6	1119	0,85	MR IV 250 - 55 × 400 200 L	4 64	
23,2	22,2	24,3	1046	0,71	MR V 250 - 55 × 400 200 L	4 63	
22,8	27,4	26,1	912	1,25	MR IV 250 - 48 × 350 200 L	* 4 51,1	
25	28	26,1	891	1,18	MR IV 250 - 55 × 400 200 L	4 50	
	28	24,9	849	0,95	MR V 250 - 55 × 400 200 L	4 50	
17	35	26,1	713	0,8	MR IV 200 - 48 × 350 200 L	* 4 40	
17,7	35	24,9	680	0,67	MR V 200 - 55 × 400 200 L	4 40	
	35	26,3	719	1,4	MR IV 250 - 55 × 400 200 L	4 40	
	35	25,2	687	1,18	MR V 250 - 55 × 400 200 L	4 40	
19,9	43,8	26,7	582	0,95	MR IV 200 - 48 × 350 200 L	* 4 32	
19,4	43,8	25,4	554	0,85	MR V 200 - 55 × 400 200 L	4 32	
	43,8	26,9	587	1,7	MR IV 250 - 55 × 400 200 L	4 32	
	43,8	26,3	574	1,25	MR V 250 - 55 × 400 200 L	4 32	
25,1	56	26,4	451	0,95	MR V 200 - 55 × 400 200 L	4 25	

$P_1$ kW	$n_2$ min <sup>-1</sup>	$P_2$ kW	$M_2$ daN m	$f_s$	Riduttore - Motore Gear reducer - Motor	$i$	
1)					2)		
30	56	26,7	455	1,7	MR V 250 - 55 × 400 200 L	4 25	
	70	26,7	364	1,18	MR V 200 - 55 × 400 200 L	4 20	
	70	26,8	366	2,12	MR V 250 - 55 × 400 200 L	4 20	
	87,5	27,1	296	1,4	MR V 200 - 55 × 400 200 L	4 16	
	87,5	27,3	298	2,5	MR V 250 - 55 × 400 200 L	4 16	
	108	27,3	242	1,6	MR V 200 - 55 × 400 200 L	4 13	
37	25	28	32,2	1099	0,95	MR IV 250 - 60 × 450 225 S	4 50
	25,7	28	30,7	1047	0,75	MR V 250 - 60 × 450 225 S	4 50
	26,4	35	32,5	886	1,12	MR IV 250 - 60 × 450 225 S	4 40
	27,3	35	31,1	848	0,95	MR V 250 - 60 × 450 225 S	4 40
	19,4	43,8	31,3	683	0,67	MR V 200 - 55 × 400 200 LG	4 32
	31,2	43,8	33,2	724	1,32	MR IV 250 - 60 × 450 225 S	4 32
		43,8	32,4	708	1	MR V 250 - 60 × 450 225 S	4 32
	25,1	56	32,6	556	0,75	MR V 200 - 55 × 400 200 LG	4 25
		56	32,9	561	1,4	MR V 250 - 60 × 450 225 S	4 25
	27	70	32,9	449	0,95	MR V 200 - 55 × 400 200 LG	4 20
		70	33,1	451	1,7	MR V 250 - 60 × 450 225 S	4 20
	31,3	87,5	33,5	365	1,12	MR V 200 - 55 × 400 200 LG	4 16
		87,5	33,7	367	2	MR V 250 - 60 × 450 225 S	4 16
		108	33,7	299	1,32	MR V 200 - 55 × 400 200 LG	4 13
45	25	28	39,2	1336	0,8	MR IV 250 - 60 × 450 225 M	4 50
	26,4	35	39,5	1078	0,95	MR IV 250 - 60 × 450 225 M	4 40
	27,3	35	37,8	1031	0,8	MR V 250 - 60 × 450 225 M	4 40
	31,2	43,8	40,3	881	1,12	MR IV 250 - 60 × 450 225 M	4 32
	35,5	43,8	39,4	861	0,85	MR V 250 - 60 × 450 225 M	4 32
		56	40	682	1,12	MR V 250 - 60 × 450 225 M	4 25
		70	40,2	549	1,4	MR V 250 - 60 × 450 225 M	4 20
		87,5	40,9	447	1,6	MR V 250 - 60 × 450 225 M	4 16
55	35,5	43,8	48,2	1052	0,71	MR V 250 - 60 × 450 250 M	* 4 32
	39,4	56	48,9	834	0,95	MR V 250 - 60 × 450 250 M	* 4 25
	41,2	70	49,2	671	1,12	MR V 250 - 60 × 450 250 M	* 4 20
		87,5	50	546	1,32	MR V 250 - 60 × 450 250 M	* 4 16

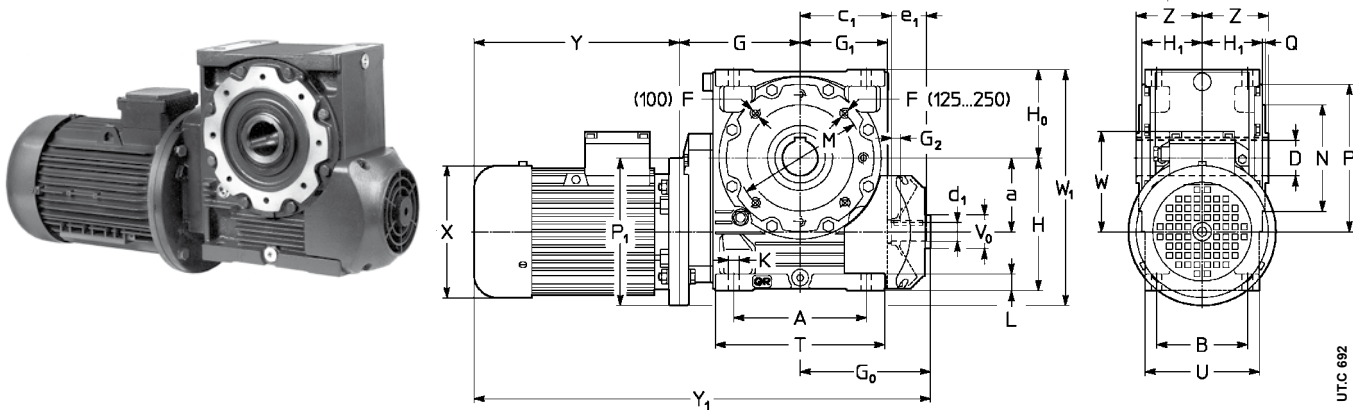
Values in red state nominal thermal power  $P_{tn}$  (ambient temperature 40 °C, continuous duty, see ch. 3.2).

1) Powers valid for continuous duty S1; **increase** possible for S2 ... S10 (see ch. 2b) in which case  $P_2$ ,  $M_2$  increase and  $f_s$  decreases proportionately.

2) For complete designation when ordering see ch. 3.1.

\* Mounting position **B5R** (see table ch. 2b).





### Design<sup>1)</sup>

standard

UO2A<sup>5)</sup>

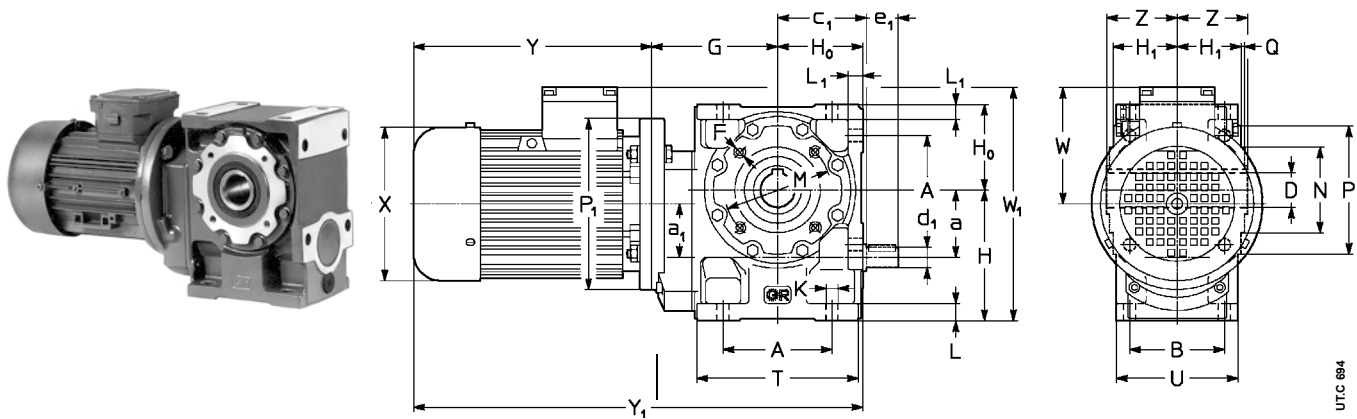
Size	a	A	c	D Ø H7	d Ø	F	G	G <sub>0</sub>	G	G <sub>2</sub>	H h11	H <sub>0</sub> h11	H h12	K Ø	L	M Ø	N Ø h6	P Ø	T	V Ø <sup>0</sup> max	Z	P Ø <sup>≈</sup>	X	Y <sub>≈</sub>	Y <sub>≈</sub>	W <sub>≈</sub>	W <sub>≈</sub>	Mass																																
																												kg	kg																															
100	90	180	130	48	28	M12	170	180	122	11	180	125	84,5	16	23	165	130	200	236	45	90	200	176	287	366	637	716	141	325	44	63	69																												
	100																																131	42	190	250	194	310	405	660	755	151	350	47	73	77														
	112																																155	58	205	221	148	15	225	150	99,5	18	28	215	180	250	218	336	435	686	785	163	350	47	82	86				
	132 <sup>7)</sup>																																160 <sup>9)</sup>	257	445	553	815	923	194	375	48	117	126																	
125	100	225	155	60	32	M12 <sup>3)</sup>	205	221	148	15	225	150	99,5	18	28	215	180	250	287	50	106	250	194	310	405	736	831	151	400	80	106	110																												
	112																																155	58	205	221	148	15	225	150	99,5	18	28	215	180	250	218	336	435	686	785	163	350	47	82	86				
	132																																160 <sup>9)</sup>	257	445	553	815	923	194	375	48	117	126																	
	160 <sup>9)</sup>																																257	445	553	815	923	194	375	48	117	126																		
160	112	272	187	70	38	M14 <sup>3)</sup>	247	255	178	15	280	180	118,5	22	33	265	230	300	345	60	125	250	218	336	435	838	937	163	465	140	175	179																												
	132																																183	58	260	255	178	15	280	180	118,5	22	33	265	230	300	345	60	125	250	218	336	435	838	937	163	465	140	175	179
	160																																183	58	260	255	178	15	280	180	118,5	22	33	265	230	300	345	60	125	250	218	336	435	838	937	163	465	140	175	179
	180 <sup>9)</sup>																																183	58	260	255	178	15	280	180	118,5	22	33	265	230	300	345	60	125	250	218	336	435	838	937	163	465	140	175	179
200	132	342	235	90	48	M16 <sup>3)</sup>	292	324	222	20	335	225	137,5	27	40	300	250	350	431	80	150	300	257	445	553	1061	1169	194	575	245	314	323																												
	160																																214	82	305	324	222	20	335	225	137,5	27	40	300	250	350	431	80	150	300	257	445	553	1061	1169	194	575	245	314	323
	180																																214	82	305	324	222	20	335	225	137,5	27	40	300	250	350	431	80	150	300	257	445	553	1061	1169	194	575	245	314	323
	200 <sup>9)</sup>																																214	82	305	324	222	20	335	225	137,5	27	40	300	250	350	431	80	150	300	257	445	553	1061	1169	194	575	245	314	323
250	160	425	287	110	55	M20 <sup>3)</sup>	360	379	277	20	410	280	163	33	50	400	350	450	537	80	180	350	314	573	640	1312	1379	258	705	400	533	514																												
	180																																250	82	370	277	20	410	280	163	33	50	400	350	450	537	80	180	350	314	573	640	1312	1379	258	705	400	533	514	
	200																																250	82	370	277	20	410	280	163	33	50	400	350	450	537	80	180	350	314	573	640	1312	1379	258	705	400	533	514	
	225																																250	82	370	277	20	410	280	163	33	50	400	350	450	537	80	180	350	314	573	640	1312	1379	258	705	400	533	514	
250 <sup>9)</sup>	250	250	287	110	55	M20 <sup>3)</sup>	360	379	277	20	410	280	163	33	50	400	350	450	537	80	180	350	314	573	640	1312	1379	258	705	400	533	514																												

- 1) See ch. 3.1 for motor design.
- 2) Working length of thread 2 · F.
- 3) Holes turned through 22° 30' with respect to the drawing.
- 4) Values valid for brake motor.
- 5) Prearranged design for worm shaft extension (see ch. 2).
- 6) Mounting position **B5R** (see ch. 2b).
- 7) On request for 132M 4 also available mounting position B5R (see ch. 2b).
- 8) Values valid for gearmotor without motor.
- 9) **Brake motor 160, 180L, 200 (cat. TX) not possible.**

### Mounting positions - direction of rotation - and oil quantities [l]

	B3	B6	B7 <sup>1)</sup>	B8	V5	V6	Size	B3	B6, B7	B8	V5, V6
							100	1,9	5,4	4,2	3
							125, 126	3,4	10	8,2	5,7
							160, 161	5,6	18	15	10
							200	9,5	33	30	20
							250	17	57	51	34

1) Sizes 200 and 250 in **B7**, mounting position with  $n_1 > 710 \text{ min}^{-1}$ , carry a price addition.



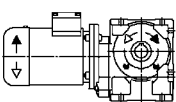
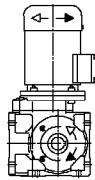
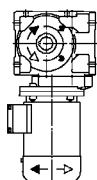
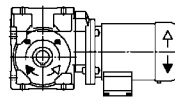
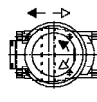

### Design<sup>1)</sup>

standard **UO3A**  
 worm extension **UO3D**

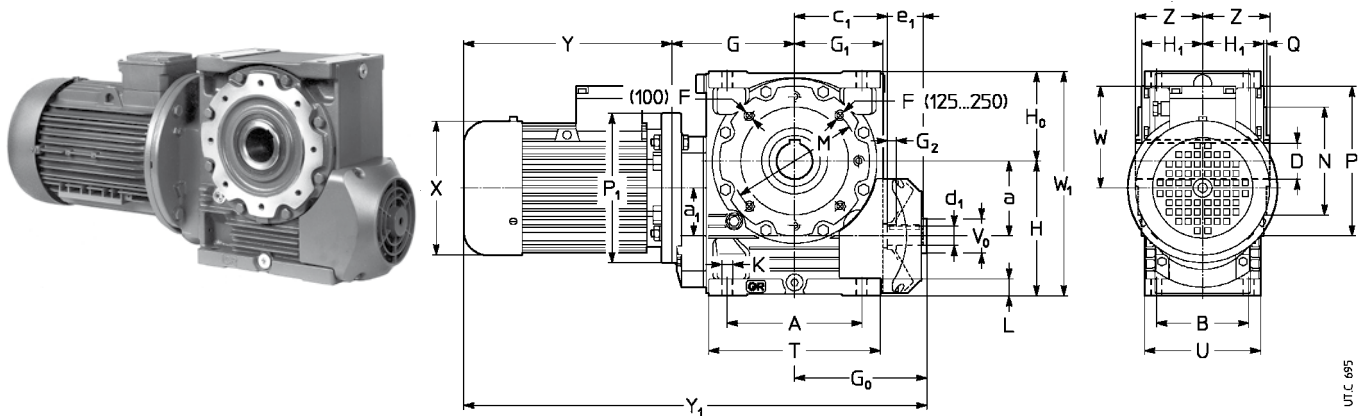
Size		a	A	c	D	d	F	G	H	H <sub>0</sub>	H <sub>1</sub>	K	L	M	N	P	T	Z	P	X	Y	Y	W	W	Mass				
red.	motor	a	B		∅ H7	∅ e	2)		h11	h11	h12	∅	L	∅	∅ h6	∅ Q	∅ U		∅		≈ 3)	≈ 3)	≈ 8)	≈ 3)	kg				
<b>32</b>	<b>63</b>	32 32	61 52	51	19	11 20	M5 4)	76	71	48	34,5	7	10 8,5	75	55 5)	90 3	91 66	39	140	123	189	244	313	368	95	166	4	9	11
<b>40</b>	<b>63</b> <b>71</b>	40 40	70 62	57,5	24	14 25	M6 4)	87	82	56	41,5	9,5	12 10	85	68 5)	105 3	106 80	46	140 160	123 138	189 216	244 278	332 359	387 421	95 112	177 194	7	12	14
<b>50</b>	<b>63</b> <b>71</b> <b>80</b> <sup>6)</sup>	50 40	86 75	70,5	28	16 30	M6 4)	98	100	67	49	9,5	13 12	100	85 5)	120 3	126 95	53 69	140 160 200	123 138 156	189 216 233	244 278 302	354 381 443	409 443 467	95 112 121	185 202 221	10	15	17
<b>63</b> <b>64</b>	<b>71</b> <b>80</b> <b>90</b>	63 50	102 90	83	32	19 30	M8	118	125	80	58,5	11,5	16 14	100	80	120 3	151 114	63	160 200 200	138 156 176	216 233 287	278 302 366	414 431 485	476 500 564	112 121 141	224 233 253	16	23	26
<b>80</b> <b>81</b>	<b>71</b> <b>80</b> <b>90</b> <b>100</b> <sup>7)</sup>	80 50	132 106	103	38 (80) 40 (81)	24 36	M10	138	150	100	69,5	14	20 17	130	110	160 3,5	189 135	75	160 200 200	138 156 176	216 233 287	278 302 366	454 471 525	516 540 604	112 121 141	250 250 261	26	33	36

- 1) See ch. 3 for motor design.
- 2) Working length of thread 2 · F.
- 3) Values valid for brake motor.
- 4) Holes turned through 45° with respect to the drawing.
- 5) Tolerance it8.
- 6) Option of P<sub>1</sub> = 160 (m.p. B5A, ved. cap. 2b), with price addition: consult us.
- 7) Mounting position **B5R** (see ch. 2b);
- 8) Values valid for gearmotor without motor.

### Mounting positions - direction of rotation - and oil quantities [l]

	B3	B6	B7	B8	V5	V6	Size	B3	B6, B7	B8	V5, V6
							<b>32</b>	0,2	0,25	0,2	0,2
							<b>40</b>	0,32	0,4	0,32	0,32
							<b>50</b>	0,5	0,7	0,5	0,5
							<b>63, 64</b>	1	1,3	1	1
							<b>80, 81</b>	1,5	2,5	2	1,5

UTC 696



UT.C. 695

### Design<sup>1)</sup>

standard

UO2A<sup>5)</sup>

Size		a	A	c	D Ø H7	d Ø	F	G	G <sub>0</sub>	G	G <sub>2</sub>	H h11	H <sub>0</sub> h11	H h12	K Ø	L	M Ø	N Ø h6	P Ø	T	V Ø <sup>0</sup> max	Z	P Ø ≈	X	Y ≈	Y ≈	W ≈	W ≈	Mass kg					
red.	motor	a <sub>1</sub>	B		e	2)												Q	U						4)	4)	7)	4)						
100	80	100	180	130	48	28	M12	170	180	122	11	180	125	84,5	16	23	165	130	200	236	45	90	200	156	233	302	583	652	121	305	45	57	60	
	90	63	131		42														3,5	165			200	176	287	366	637	716	141	305	45	64	70	
	112																						250	194	310	405	660	755	151	305	48	74	78	
125	90	125	225	155	60	32	M12 <sup>5)</sup>	205	221	148	15	225	150	99,5	18	28	215	180	250	287	50	106	200	176	287	366	713	792	141	375	80	99	105	
	100	80	155		58													4	194				250	194	310	405	736	831	151	375	83	109	113	
	112																						250	218	336	435	762	861	163	375	83	118	125	
	132																						300	257	445	553	871	979	194	375	85	154	163	
160	100	160	272	187	70	38	M14 <sup>5)</sup>	247	255	178	15	280	180	118,5	22	33	265	230	300	345	60	125	250	194	310	405	812	907	151	460	140	166	170	
	112	100	183		(160)	58													4	232			250	218	336	435	838	937	163	460	140	175	182	
	132				75																		300	257	445	553	947	1055	194	460	145	214	233	
	160				(161)			260																350	314	573	640	1088	1155	258	478	150	283	264
	180M																							350	354	613	640	1128	1155	278	498	150	285	274
200	100	200	342	235	90	48	M16 <sup>5)</sup>	292	324	222	20	335	225	137,5	27	40	300	250	350	431	80	150	250	194	310	405	926	1021	151	560	245	271	275	
	112	100	214		82														5	270			250	218	336	435	952	1051	163	560	245	280	284	
	132																						300	257	445	553	1061	1169	194	560	251	319	328	
	160							305																350	314	573	640	1202	1269	258	560	255	388	369
	180																							350	354	613	734	1242	1363	278	560	255	412	413
	200 <sup>6)</sup>																							350	354	654	734	1283	1363	278	560	255	501	437
250	132	250	425	287	110	55	M20 <sup>5)</sup>	360	379	277	20	410	280	163	33	50	400	350	450	537	80	180	300	257	445	553	1184	1292	194	690	405	474	483	
	160	125	250		82	3)													5	320			350	314	573	640	1312	1379	258	690	410	543	524	
	180																						350	354	613	734	1352	1473	278	690	410	567	568	
	200																						400	354	654	734	1393	1473	278	690	410	656	592	
	225								370															450	411	710	-	1459	-	298	690	415	739	-

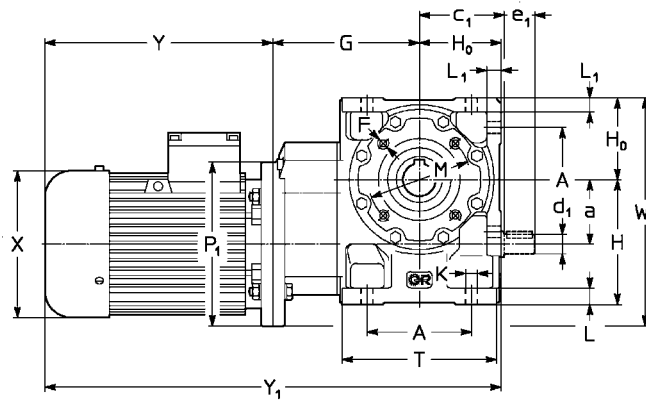
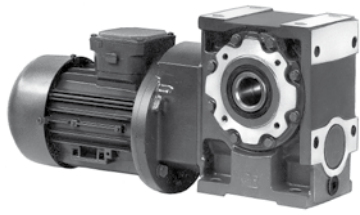
- 1) See ch. 3 for motor design.
- 2) Working length of thread 2 · F.
- 3) Holes turned through 22° 30' with respect to the drawing.
- 4) Values valid for brake motor.
- 5) Prearranged design for worm shaft extension (see ch. 2).
- 6) Mounting position **B5R** (see ch. 2b).
- 7) Values valid for gearmotor without motor.

### Mounting positions - direction of rotation - and oil quantities [l]

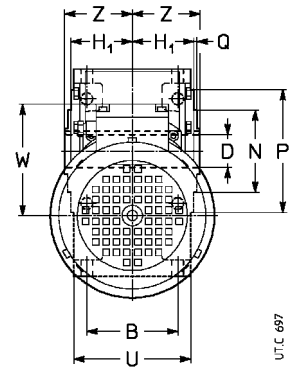
B3	B6 <sup>1)</sup>	B7	B8	V5	V6	Size	B3	B6, B7	B8	V5, V6
						100	2,1	6,3	4,5	3,3
						125, 126	3,8	11,6	8,8	6,3
						160, 161	6,5	20,8	16,5	11,2
						200	10,4	38	31,5	21,2
						250	18,3	67	53	35,7

UT.C. 701

1) Sizes 100 ... 250 in mounting position **B6** carry a price addition.



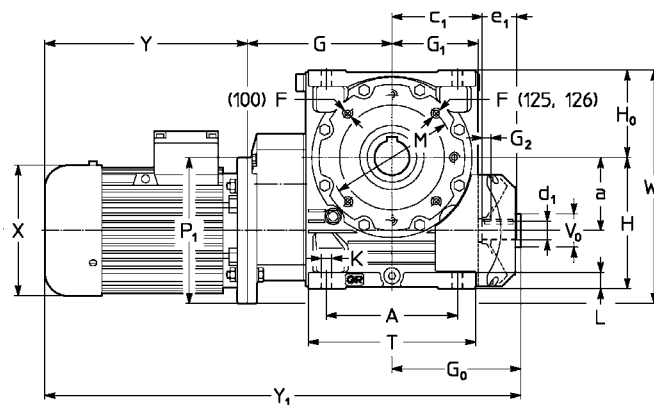
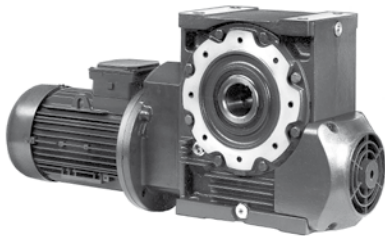
**MR 2IV 40 ... 81**



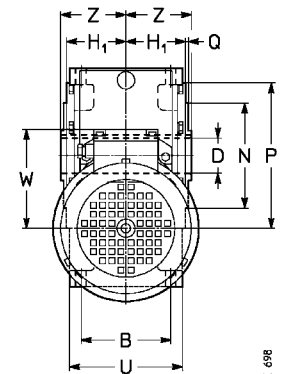
UT.C. 697

**Design<sup>1)</sup>**  
standard  
worm extension

**UO3A**  
**UO3D**



**MR 2IV 100 ... 126**



UT.C. 698

**Design<sup>1)</sup>**  
standard

**UO2A<sup>4)</sup>**

Size	a	A	c	D Ø H7	d Ø	F	G	G <sub>0</sub>	G	G <sub>2</sub>	H h11	H <sub>0</sub> h11	H h12	K Ø	L	L	M Ø	N Ø h6	P Ø	T	V <sub>0</sub> Ø max	Z	P Ø ≈	X	Y ≈	Y ≈	W ≈	W ≈	Mass					
																													kg					
red.	<b>B5</b>	<b>B</b>	<b>e</b>	M6 5)	106	—	—	—	—	—	82	56	41,5	9,5	12	10	85	68 6)	105 3	106 80	—	46	140	123	189	244	351	406	95	166	7	12	14	
<b>40</b>	<b>63</b>	40	70 6	57,5	24	14 25	M6 5)	106	—	—	82	56	41,5	9,5	12	10	85	68 6)	105 3	106 80	—	46	140	123	189	244	351	406	95	166	7	12	14	
<b>50</b>	<b>63</b> <b>71</b>	50	86 75	70,5	28	16 30	M6 5)	117	—	—	100	67	49	9,5	13	12	100	85 6)	120 95	126 95	—	53	140	123	189	244	373	428	95	187	10	15	17	
<b>63</b> <b>64</b>	<b>71</b> <b>80</b>	63	102 90	83	32	19 30	M8	145	—	—	125	80	58,5	11,5	16	14	100	80	120 3	151 114	—	63	160	138	216	278	441	503	112	223	17	24	27	
<b>80</b> <b>81</b>	<b>71</b> <b>80</b>	80	132 106	103	38 (80) 40 (81)	24 36	M10	165	—	—	150	100	69,5	14	20	17	130	110	160 3,5	189 135	—	75	160	138	216	278	481	543	112	260	27	34	37	
<b>100</b>	<b>80</b> <b>90</b>	100	180 131	130	48	28 42	M12	203	180	122	11	180	125	84,5	16	23	—	165	130	200 3,5	236 165	45	90	200	156	233	302	316	685	121	325	48	60	63
<b>125</b> <b>126</b>	<b>90</b> <b>100</b> <b>112M</b>	125	225 155	155	60	32 58	M12 <sup>8)</sup>	249	221	148	15	225	150	99,5	18	28	—	215	180	250 4	287 194	50	106	200	176	287	366	757	836	141	375	80	99	105

- 1) See ch. 3 for motor design.
- 2) Working length of thread 2 : F.
- 3) Values valid for brake motor.
- 4) Prearranged design for worm shaft extension (see ch. 2).
- 5) Holes turned through 45° with respect to the drawing.
- 6) Tolerance t8.
- 7) Values valid for gearmotor without motor.

**Forme costruttive - senso di rotazione - e quantità d'olio [l]**

**Mounting positions - direction of rotation - and oil quantities [l]**

B3	B6	B7	B8	V5	V6	Grand. Size	B3	B6, B7	B8	V5, V6
						<b>40</b>	0,42	0,5	0,42	0,42
						<b>50</b>	0,6	0,8	0,6	0,6
						<b>63, 64</b>	1,2	1,55	1,2	1,2
						<b>80, 81</b>	1,7	2,8	2,3	1,8
						<b>100</b>	2,4	6,8	4,8	3,6
						<b>125,126</b>	4,2	12,8	9,3	6,8

UT.C. 699

Schemi di grand. 40 ... 81 validi anche per grand. 100 ... 126.


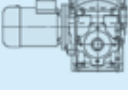
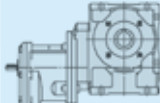

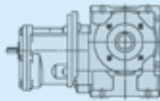
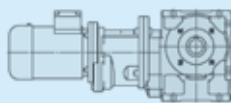
Schemes for sizes 40 ... 81 valid also for sizes 100 ... 126.

### Tabella A - Nominal torques for final gear reducer

$n_2$ min <sup>-1</sup>	Final gear reducer size / $i$ worm gear pair											
	50/20			63/25			80/25			81/25		
	$M_{N2}$ daN m	$\eta$	$M_{2max}$ daN m	$M_{N2}$ daN m	$\eta$	$M_{2max}$ daN m	$M_{N2}$ daN m	$\eta$	$M_{2max}$ daN m	$M_{N2}$ daN m	$\eta$	$M_{2max}$ daN m
<b>11,2</b>	20,1	0,7	33,4	32	0,7	58	63	0,72	109	75	0,72	118
<b>9</b>	20,5	0,68	35	33,8	0,69	61	65	0,71	113	77	0,71	123
<b>4,5</b>	21,3	0,66	38,4	37,8	0,66	68	72	0,68	127	82	0,68	137
<b>2,24</b>	23,9	0,64	40,2	42,9	0,64	73	80	0,65	133	87	0,65	141
<b>1,12</b>	25	0,62	40,2	47,5	0,62	73	80	0,63	133	90	0,63	141
<b>0,56</b>	25*	0,6	40,2	47,5	0,6	73	80*	0,61	133	90*	0,61	141
<b>0,28</b>	25**	0,58	40,2	47,5*	0,58	73	80**	0,59	133	90**	0,59	141
<b>0,14</b>	25**	0,57	40,2	47,5*	0,57	73	80**	0,58	133	90**	0,58	141
<b>≤ 0,071</b>	25**	0,55	40,2	47,5*	0,55	73	80**	0,56	133	90**	0,56	141
$M_2$ Size [daN m]	<b>25</b>			<b>47,5</b>			<b>80</b>			<b>90</b>		

\*, \*\* In these cases  $f_s$  required, provided that it always results  $\geq 1$ , can be reduced of **1,12** (\*) or **1,18** (\*\*).

### Table B - Types of combined units

Type of combined unit	Final gear reducer size			
	50	63	80	81
<p><b>RV + RV</b></p>  <p><b>RV + MR V</b></p>  <p>1)</p> <p><math>i_N \approx 250 \dots 1\ 600</math></p>	<p><b>RV 50/20</b></p> <p>+</p> <p><b>RV or MR V 32</b></p> <p><math>i_{final} = 20</math></p>	<p><b>RV 63/25</b></p> <p>+</p> <p><b>RV or MR V 32</b></p> <p><math>i_{final} = 25</math></p>	<p><b>RV 80/25</b></p> <p>+</p> <p><b>RV or MR V 40<sup>5)</sup></b></p> <p>5) <math>i = 63</math> is not admitted.</p> <p><math>i_{final} = 25</math></p>	<p><b>RV 81/25</b></p> <p>+</p> <p><b>RV or MR V 40<sup>5)</sup></b></p> <p>5) <math>i = 63</math> is not admitted.</p> <p><math>i_{final} = 25</math></p>
<p><b>MR V + R 2I, 3I</b></p>  <p><b>MR V + MR 2I, 3I</b></p>  <p><math>i_N \approx 160 \dots 4\ 000</math></p>	<p><b>MR V 50 - 19x160 - 20<sup>3)</sup></b></p> <p>+</p> <p><b>R 2I or MR 2I, 3I 40</b></p> <p><math>i_{final} = 20</math></p>	<p><b>MR V 63 - 19x160 - 25<sup>3)</sup></b></p> <p>+</p> <p><b>R 2I or MR 2I, 3I 40</b></p> <p><math>i_{final} = 25</math></p>	<p><b>MR V 80 - 24x200 - 25</b></p> <p>+</p> <p><b>R 2I, 3I or MR 2I, 3I 50<sup>4)</sup></b></p> <p>for <math>M_{N2} \leq 60</math> daN m</p> <p><b>MR V 80 - 19x160 - 25<sup>3)</sup></b></p> <p>+</p> <p><b>R 2I o/ou MR 2I, 3I 40</b></p> <p><math>i_{final} = 25</math></p>	<p><b>MR V 81 - 24x200 - 25</b></p> <p>+</p> <p><b>R 2I, 3I or MR 2I, 3I 50<sup>4)</sup></b></p> <p><math>i_{final} = 25</math></p>
<p><b>MR IV + R 2I</b></p>  <p><b>MR IV + MR 2I, 3I</b></p>  <p><math>i_N \approx 400 \dots 10\ 000</math></p>	<p><b>MR IV 50 - 14x140 - 50,7<sup>2)</sup></b></p> <p>+</p> <p><b>R 2I or MR 2I, 3I 32</b></p> <p>design: <b>shaft end <math>\varnothing 14</math></b></p> <p><math>i_{final} = 50,7</math></p>	<p><b>MR IV 63 - 19x160 - 63,5<sup>3)</sup></b></p> <p>+</p> <p><b>R 2I or MR 2I, 3I 40</b></p> <p><math>i_{final} = 63,5</math></p>	<p><b>MR IV 80 - 19x160 - 63,5<sup>3)</sup></b></p> <p>+</p> <p><b>R 2I or MR 2I, 3I 40</b></p> <p><math>i_{final} = 63,5</math></p>	<p><b>MR IV 81 - 19x160 - 63,5<sup>3)</sup></b></p> <p>+</p> <p><b>R 2I or MR 2I, 3I 40</b></p> <p><math>i_{final} = 63,5</math></p>

For initial gear reducer performance see: this catalog ch. 3.5 or 3.7 for worm gear reducer, and catalog E ch. 3.4 or 3.6 for coaxial gear reducer.

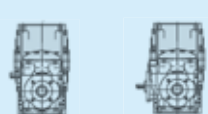



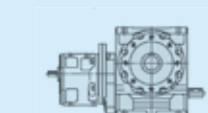
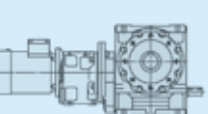
- 1) An anchor link is fitted between initial and final gear reducer.
- 2) The gearmotor has 140 mm motor mounting flange (dimension  $P_0$ , ch. 3.10).
- 3) The gearmotor has 160 mm motor mounting flange (dimension  $P_0$ , ch. 3.10).
- 4) Gear reducer in «oversized B5 flange» (see cat. E).

**Table A - Nominal torques for final gear reducer**

$n_2$ min <sup>-1</sup>	Final gear reducer size / $i$ worm gear pair								
	100/25			125/32			160/32		
	$M_{N2}$ daN m	$\eta$	$M_{2max}$ daN m	$M_{N2}$ daN m	$\eta$	$M_{2max}$ daN m	$M_{N2}$ daN m	$\eta$	$M_{2max}$ daN m
11,2	129	0,74	215	200	0,74	339	372	0,76	636
9	133	0,73	229	208	0,73	361	391	0,75	680
4,5	145	0,69	257	230	0,69	413	435	0,71	784
2,24	154	0,67	268	254	0,66	458	494	0,68	850
1,12	160	0,65	268	279	0,64	468	500	0,65	850
0,56	160*	0,63	268	300	0,61	468	500*	0,63	850
0,28	160**	0,61	268	300*	0,6	468	500**	0,61	850
0,14	160**	0,59	268	300*	0,58	468	500**	0,59	850
≤ 0,071	160**	0,57	268	300*	0,56	468	500**	0,57	850
$M_2$ Size [daN m]	<b>160</b>			<b>300</b>			<b>500</b>		

\*, \*\* In these cases  $f_s$  required, provided that it always results  $\geq 1$ , can be reduced of 1,12 (\*) or 1,18 (\*\*).

**Table B - Types of combined units**

Type of combined unit	Final gear reducer size		
	100	125	160
<p>RV + RV RV + RV</p>  <p>RV + MRV RV + MRV</p>  <p>1)</p> <p><math>i_N \approx 315 \dots 8\,000</math></p>	<p><b>R V 100/25</b></p> <p>+</p> <p><b>R V, IV or MR V, IV 50</b></p> <p><math>i_{final} = 25</math></p>	<p><b>R V 125/32</b></p> <p>+</p> <p><b>R V, IV or MR V, IV 63</b></p> <p><math>i_{final} = 32</math></p>	<p><b>R V 160/32</b></p> <p>+</p> <p><b>R V, IV or MR V, IV 80</b></p> <p><math>i_{final} = 32</math></p>
<p>MRV + R 2l, 3l</p>  <p>MRV + MR 2l, 3l</p>  <p><math>i_N \approx 200 \dots 5\,000</math></p>	<p><b>MR V 100 - 28x250 - 25</b></p> <p>+</p> <p><b>R 2l, 3l or MR 2l, 3l 63<sup>4)</sup></b></p> <p>for <math>M_{N2} \leq 112</math> daN m</p> <p><b>MR V 100 - 24x200 - 25</b></p> <p>+</p> <p><b>R 2l, 3l or MR 2l, 3l 50<sup>4)</sup></b></p> <p><math>i_{final} = 25</math></p>	<p><b>MR V 125 - 28x250 - 32</b></p> <p>+</p> <p><b>R 2l, 3l or MR 2l, 3l 63<sup>4)</sup></b></p> <p><math>i_{final} = 32</math></p>	<p><b>MR V 160 - 38x300 - 32</b></p> <p>+</p> <p><b>R 2l, 3l or MR 2l, 3l 80<sup>4)</sup></b></p> <p>for <math>M_{N2} \leq 400</math> daN m</p> <p><b>MR V 160 - 38x250 - 32<sup>5)</sup></b></p> <p>+</p> <p><b>R 2l, 3l or MR 2l, 3l 64<sup>4)</sup></b></p> <p>for <math>M_{N2} \leq 315</math> daN m</p> <p><b>MR V 160 - 28x250 - 32</b></p> <p>+</p> <p><b>R 2l, 3l or MR 2l, 3l 63<sup>4)</sup></b></p> <p><math>i_{final} = 32</math></p>
<p>MR IV + R 2l, 3l</p>  <p>MR IV + MR 2l, 3l</p>  <p><math>i_N \approx 500 \dots 12\,500</math></p>	<p><b>MR IV 100 - 24x200 - 63,5</b></p> <p>+</p> <p><b>R 2l, 3l or MR 2l, 3l 50<sup>4)</sup></b></p> <p><math>i_{final} = 63,5</math></p>	<p><b>MR IV 125 - 28x250 - 81,1</b></p> <p>+</p> <p><b>R 2l, 3l or MR 2l, 3l 63<sup>4)</sup></b></p> <p><math>i_{final} = 81,1</math></p>	<p><b>MR IV 160 - 28x250 - 102</b></p> <p>+</p> <p><b>R 2l, 3l or MR 2l, 3l 63<sup>4)</sup></b></p> <p><math>i_{final} = 102</math></p>

For initial gear reducer performance see: this catalog ch. 3.5 or 3.7 for worm gear reducer, and catalog E for coaxial gear reducer.

1) An anchor link is fitted between initial and final gear reducer.

4) Gear reducer in «oversized B5 flange» (see cat. E); size 63 has a low speed shaft reduced to 28 mm: «oversized B5 flange - Ø 28».

5) The gearmotor has 250 mm motor mounting flange (dimension  $P_{Dv}$ , ch. 3.10).

6) The gearmotor has 300 mm motor mounting flange (dimension  $P_{Dv}$ , ch. 3.10).

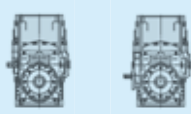
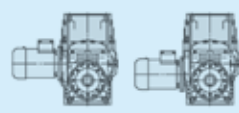
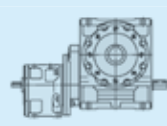
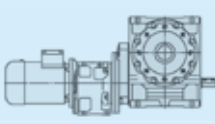
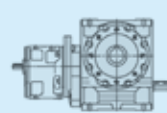
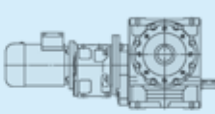
7) The gearmotor has 350 mm motor mounting flange (dimension  $P_{Dv}$ , ch. 3.10).

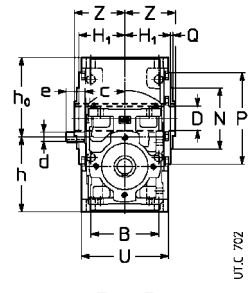
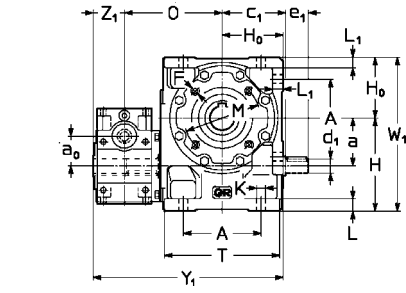


**Table A - Nominal torques for final gear reducer**

$n_2$ min <sup>-1</sup>	Final gear reducer size / $i$ worm gear pair								
	161/32			200/32			250/40		
	$M_{N2}$ daN m	$\eta$	$M_{2max}$ daN m	$M_{N2}$ daN m	$\eta$	$M_{2max}$ daN m	$M_{N2}$ daN m	$\eta$	$M_{2max}$ daN m
11,2	442	0,76	691	730	0,78	1 201	1 190	0,79	2 013
9	466	0,75	739	767	0,77	1 258	1 270	0,78	2 072
4,5	516	0,71	851	851	0,73	1 487	1 440	0,73	2 467
2,24	556	0,68	921	923	0,69	1 662	1 562	0,69	2 812
1,12	560	0,65	921	1 000	0,67	1 736	1 704	0,66	3 034
0,56	560*	0,63	921	1 000*	0,64	1 736	1 900	0,64	3 134
0,28	560**	0,61	921	1 000**	0,63	1 736	1 900*	0,61	3 134
0,14	560**	0,59	921	1 000**	0,61	1 736	1 900**	0,60	3 134
≤ 0,071	560**	0,57	921	1 000**	0,58	1 736	1 900**	0,57	3 134
$M_2$ Size [daN m]	<b>560</b>			<b>1 000</b>			<b>1 900</b>		

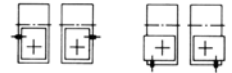
**Table B - Types of combined units**

Type of combined unit	Final gear reducer size		
	161	200	250
<p>RV + RV   RV + RIV</p>  <p>RV + MRV   RV + MRIV</p>  <p>1)   U.T.C. 750</p> <p><math>i_N \approx 315 \dots 10\,000</math></p>	<p><b>RV 161/32</b></p> <p>+</p> <p><b>RV, IV or MR V, IV 80</b></p> <p><math>i_{final} = 32</math></p>	<p><b>RV 200/32</b></p> <p>+</p> <p><b>RV, IV or MR V, IV 100</b></p> <p><math>i_{final} = 32</math></p>	<p><b>RV 250/40</b></p> <p>+</p> <p><b>RV, IV or MR V, IV 125</b></p> <p><math>i_{final} = 40</math></p>
<p>MRV + R 2I, 3I</p>  <p>MRV + MR 2I, 3I</p>  <p><math>i_N \approx 200 \dots 6\,300</math></p>	<p><b>MR V 161 - 38x300 - 32</b></p> <p>+</p> <p><b>R 2I, 3I or MR 2I, 3I 80<sup>(4)</sup></b></p> <p>for <math>M_{N2} \leq 400</math> daN m</p> <p><b>MR V 161 - 38x250 - 32<sup>(5)</sup></b></p> <p>+</p> <p><b>R 2I, 3I or MR 2I, 3I 64<sup>(4)</sup></b></p> <p><math>i_{final} = 32</math></p>	<p><b>MR V 200 - 48x350 - 32</b></p> <p>+</p> <p><b>R 2I, 3I or MR 2I, 3I 100<sup>(4)</sup></b></p> <p>for <math>M_{N2} \leq 800</math> daN m</p> <p><b>MR V 200 - 48x300 - 32<sup>(6)</sup></b></p> <p>+</p> <p><b>R 2I, 3I or MR 2I, 3I 81<sup>(4)</sup></b></p> <p>for <math>M_{N2} \leq 670</math> daN m</p> <p><b>MR V 200 - 38x300 - 32</b></p> <p>+</p> <p><b>R 2I, 3I or MR 2I, 3I 80<sup>(4)</sup></b></p> <p><math>i_{final} = 32</math></p>	<p><b>MR V 250 - 55x350 - 40<sup>(7)</sup></b></p> <p>+</p> <p><b>R 2I, 3I or MR 2I, 3I 101<sup>(4)</sup></b></p> <p>for <math>M_{N2} \leq 1\,400</math> daN m</p> <p><b>MR V 250 - 48x350 - 40</b></p> <p>+</p> <p><b>R 2I, 3I or MR 2I, 3I 100<sup>(4)</sup></b></p> <p><math>i_{final} = 40</math></p>
<p>MR IV + R 2I, 3I</p>  <p>MR IV + MR 2I, 3I</p>  <p><math>i_N \approx 500 \dots 16\,000</math></p>	<p><b>MR IV 161 - 28x250 - 102</b></p> <p>+</p> <p><b>R 2I, 3I or MR 2I, 3I 63<sup>(4)</sup></b></p> <p><math>i_{final} = 102</math></p>	<p><b>MR IV 200 - 38x300 - 81,8</b></p> <p>+</p> <p><b>R 2I, 3I or MR 2I, 3I 80<sup>(4)</sup></b></p> <p><math>i_{final} = 81,8</math></p>	<p><b>MR IV 250 - 48x350 - 102</b></p> <p>+</p> <p><b>R 2I, 3I or MR 2I, 3I 100<sup>(4)</sup></b></p> <p><math>i_{final} = 102</math></p>



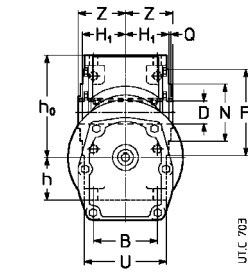
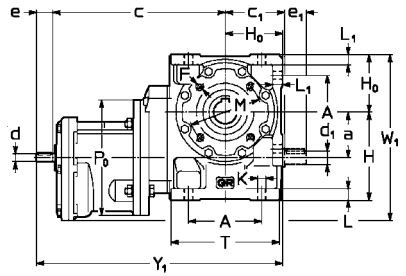
Final gear reducer size

**50 ... 81**  
RV ... + RV ... <sup>2)</sup>



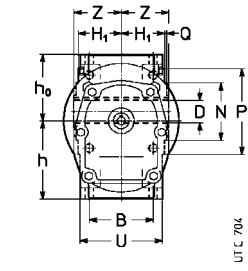
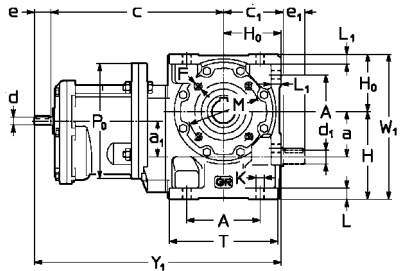
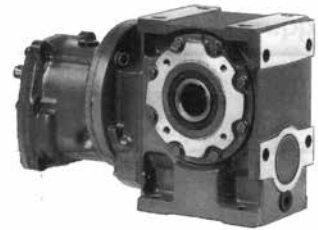
— 1 2 3

UT.C. 702



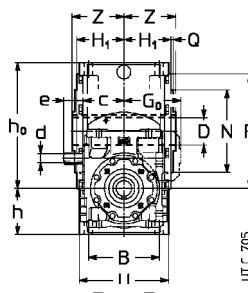
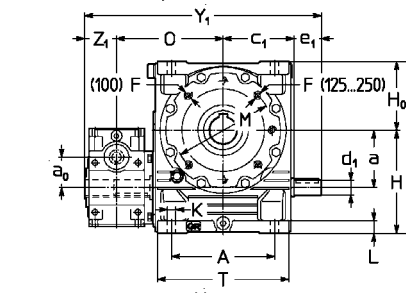
UT.C. 703

MR V ... + R 2I, 3I ...



UT.C. 704

MR IV ... + R 2I ...

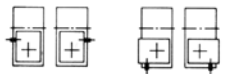


UT.C. 705

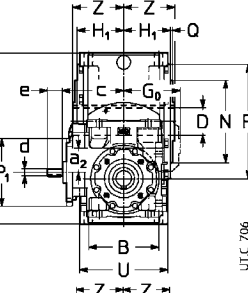
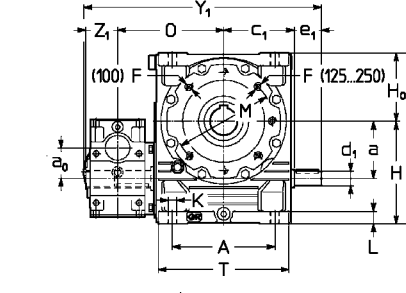
Final gear reducer size

**100 ... 250**

RV ... + RV ... <sup>2)</sup>

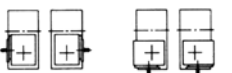


— 1 2 3

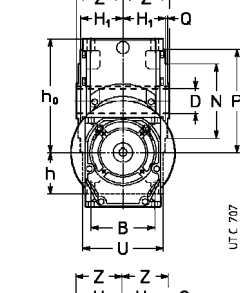
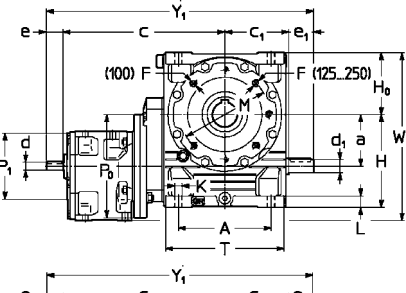


UT.C. 706

RV ... + R IV ... <sup>2)</sup>

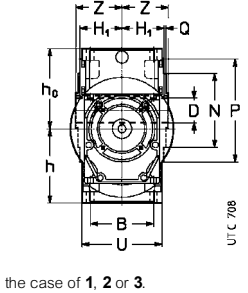
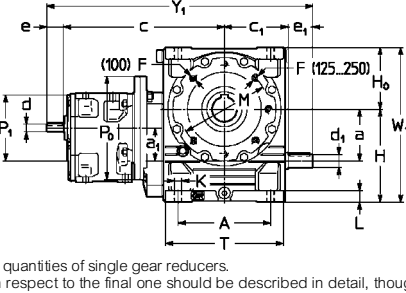
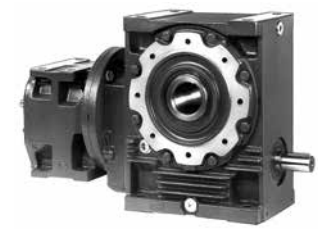


— 1 2 3



UT.C. 707

MR V ... + R 2I, 3I ...



UT.C. 708

MR IV ... + R 2I, 3I ...

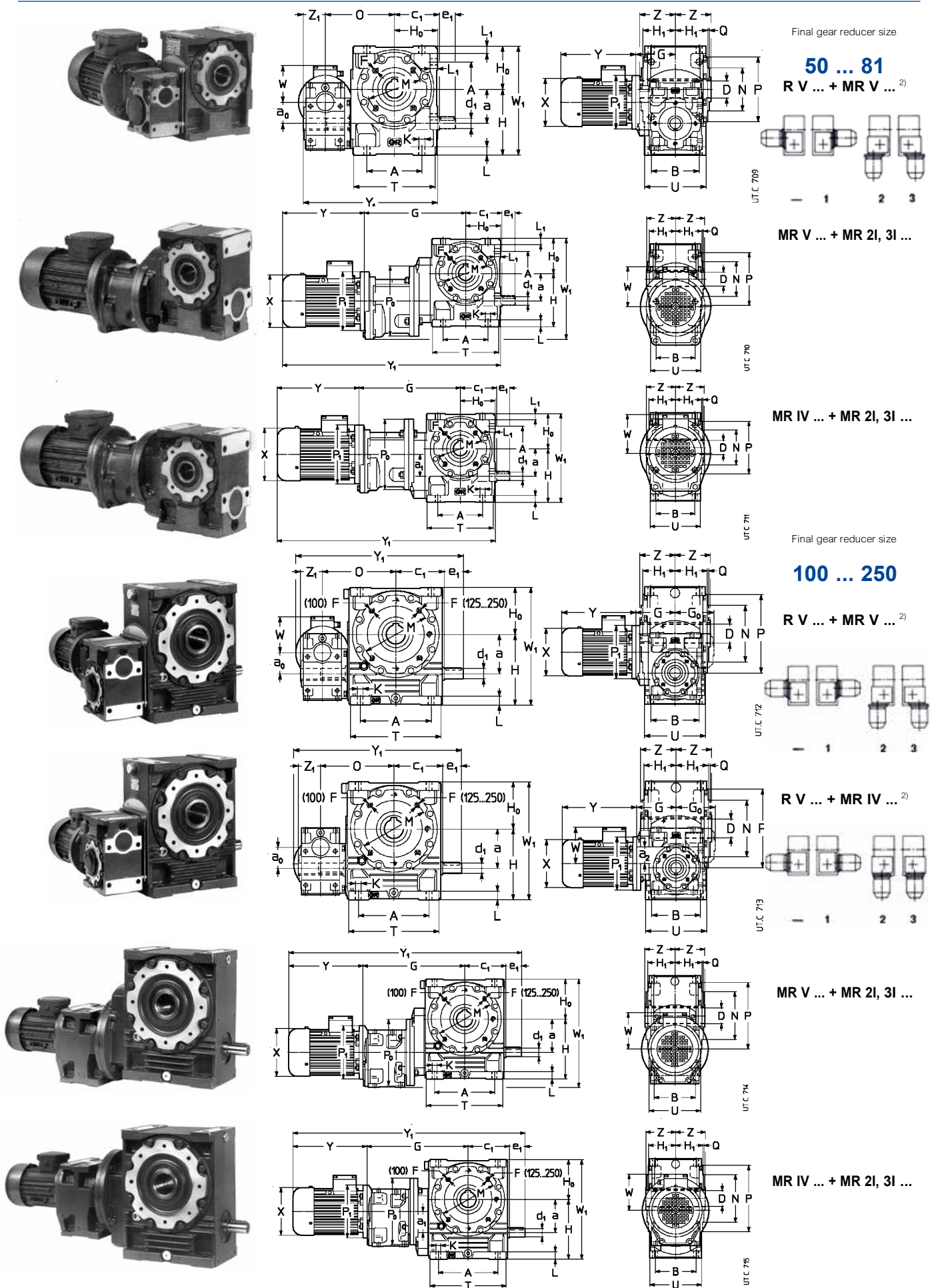
1) See catalogues for design, mounting position and oil quantities of single gear reducers.

2) The coupling position of the initial gear reducer with respect to the final one should be described in detail, though only in the case of 1, 2 or 3.

**Important:** personal safety-guards are the Buyer's responsibility (2006/42/EC).

Gear reducer size		a	a <sub>1</sub>	A	c	c <sub>1</sub>	D Ø H7	d	e	d <sub>1</sub>	F	H	H <sub>1</sub>	h	h <sub>0</sub>	K	L	M	N	O	P	P <sub>0</sub>	P <sub>1</sub>	T	W	Y <sub>1</sub>	Z	Mass kg	
final	initial	a <sub>0</sub>	a <sub>2</sub>	B						e <sub>1</sub>	1)	H <sub>0</sub>	h <sub>11</sub>	h <sub>12</sub>	h <sub>11</sub>	h <sub>11</sub>	L <sub>1</sub>	Ø	Ø h6	Ø ≈	Ø	Ø	Ø	U			Y <sub>1</sub>	Z <sub>1</sub>	
50 R V	R V 32	50	40	86	51	70,5	28	14	25	16	M 6	100	49	82	85	9,5	13	100	85	116	120	—	—	126	167	222	53	12	
	MR V R 2I 40	32	—	75	220			11	23	30	2)	67		50	117		12		4)	—	3	160		95	204	310	39	18	
	MR IV R 2I 32				191			11	20					90	77							140			167	278		18	
63 R V	R V 32	63	50	102	51	83	32	14	25	19	M 8	125	58,5	94	111	11,5	16	100	80	129	120	—	—	151	205	248	63	17	
	MR V R 2I 40	32	—	90	240			11	23	30		80		62	143		14			—	3	160		114	230	343	39	23	
	MR IV R 2I 40				240			11	23					112	93							160			205	343		23	
80 R V 81	R V 40	80	40	132	59,5	103	38	16	30	24	M 10	150	69,5	110	140	14	20	130	110	153	160	—	—	189	250	299	75	30	
	MR V R 2I 50			106	292		(80)	14	30	36		100		70	180		17			—	3,5	200	140	135	286	422	46	39	
	R 3I 50				292		40	11	23					70	180							200			286	415		39	
	R 2I 40				260		(81)	11	23					70	180							160			267	383		33	
MR IV R 2I 40					260			11	23				120	130							160				250	383		33	
100 R V	R V 50	100	63	180	70,5	130	48	19	40	28	M 12	180	84,5	130	175	16	23	165	130	187	200	—	140	236	305	412	90	52	
	R IV 50	50	40	131	107			11	23	42		125		90	215		—			—	3,5	—	—	165	305	429	53	54	
	MR V	R 2I 63				357			19	40				80	225							250	160		357	569		66	
		R 3I 63				357			16	30				80	225							250			357	559		66	
		R 2I 50				324			14	30				80	225							200	140		331	526		58	
		R 3I 50				324			11	23				80	225							200			331	519		58	
	MR IV	R 2I 50				324			14	30				143	162							200			305	526		59	
		R 3I 50				324			11	23				143	162							200			305	519		59	
125 R V	R V 63	125	80	225	83	155	60	19	40	32	M 12 <sup>5</sup>	225	99,5	163	212	18	28	215	180	222	250	—	160	287	375	498	106	88	
	R IV 63	63	50	155	127			14	30	58		150		113	262		—			—	4	—	—	194	375	515	63	91	
	MR V	R 2I 63				392			19	40				100	275							250			407	645		101	
		R 3I 63				392			16	30				100	275							250			407	635		101	
		R 3I 63				392			14	30				100	275							250			407	635		101	
MR IV R 2I 63				392			19	40				180	195							250			375	645		103			
160 R V 161	R V 80	160	100	272	103	187	70	24	50	38	M 14 <sup>6</sup>	280	118,5	200	260	22	33	265	230	268	300	—	160	345	460	588	125	154	
R IV 80	80	50	183	147		(160)	14	30	58		14 <sup>8</sup>	180		150	310		—			—	4	—	—	232	460	593	75	157	
MR V	R 2I 80				477		75	24	50				120	340							300	200		500	772		178		
	R 3I 80				477		(161)	19	40				120	340							300			500	762		178		
	R 2I 80, 81				477			19	40				120	340							300			500	762		178		
	R 3I 80, 81				477			16	30				120	340							300			500	752		178		
	R 2I 63, 64				434			19	40				120	340							250	160		472	719		160		
	R 3I 63, 64				434			16	30				120	340							250			472	709		160		
	R 3I 63, 64				434			14	30				120	340							250			472	709		160		
MR IV	R 2I 63				434			19	40				220	240							250			460	719		163		
	R 3I 63				434			16	30				220	240							250			460	709		163		
	R 3I 63				434			14	30				220	240							250			460	709		163		
200 R V	R V 100	200	100	342	130	235	90	28	60	48	M 16 <sup>8</sup>	335	137,5	235	325	27	40	300	250	328	350	—	200	431	560	735	150	276	
	R IV 100	100	63	214	181			19	40	82		225		172	388		—			—	5	—	—	270	560	745	90	281	
	MR V	R 2I 100				585			28	60				135	425							350	250		620	962		311	
		R 3I 100				585			24	50				135	425							350			620	952		311	
		R 2I 80, 81				585			19	40				135	425							350			620	942		311	
		R 2I 80, 81				522			24	50				135	425							300	200		585	889		281	
		R 3I 80, 81				522			19	40				135	425							300			585	879		281	
		R 3I 80, 81				522			16	30				135	425							300			585	869		281	
	MR IV	R 2I 80				522			24	50				235	325							300			560	889		285	
		R 3I 80				522			19	40				235	325							300			560	879		285	
		R 3I 80				522			19	40				235	325							300			560	879		285	
		R 3I 80				522			16	30				235	325							300			560	869		285	
250 R V	R V 125	250	125	425	155	287	110	32	80	55	M 20 <sup>9</sup>	410	163	285	405	33	50	400	350	401	450	—	200	537	690	876	180	456	
	R IV 125	125	80	250	216			24	50	82	3)	280		205	485		—			—	5	—	—	320	690	876	106	464	
	MR V	R 2I 100, 101				640			28	60				160	530							350	250		725	1069		465	
		R 3I 100, 101				640			24	50				160	530							350			725	1059		465	
		R 2I 100, 101				640			19	40				160	530							350			725	1049		465	
		R 3I 100, 101				640			19	40				160	530							350			725	1049		465	
	MR IV	R 2I 100				640			28	60				285	405							350			690	1069		471	
		R 3I 100				640			24	50				285	405							350			690	1059		471	
	R 3I 100				640			24	50				285	405							350			690	1059		471		
	R 3I 100				640			19	40				285	405							350			690	1049		471		

1) Working length of thread 2 · F.  
 2) Holes turned through 45° with respect to the drawing.  
 3) Holes turned through 22° 30' with respect to the drawing.  
 4) Tolerance t8.



1) See relevant catalogues for design, mounting position and oil quantities of single gear reducers.

2) The coupling position of the initial gear reducer with respect to the final one should be described in detail, though only in the case of 1, 2 or 3.

**Important:** personal safety-guards are the Buyer's responsibility (2006/42/EC).

Gear reducer size		a	a <sub>1</sub>	A	c <sub>1</sub>	D Ø H7	d Ø	F	G	H h11	H <sub>1</sub> h12	K Ø	M	N Ø h6	O ≈	P Ø	P <sub>0</sub> Ø	P <sub>1</sub> Ø	T Ø	W <sub>1</sub>	Z	X Ø	Y	Y <sub>1</sub>	w	Mass kg							
final	initial	a <sub>0</sub>	a <sub>2</sub>	B		e <sub>1</sub>	1)		H <sub>0</sub> h11		L L <sub>1</sub>			G <sub>0</sub>	Q		U	Z <sub>1</sub>				6)	6)	6)	7)	6)	6)	6)					
50	R V	MR V	32	63	50	40	86	70,5	28	16	M6	76	100	49	9,5	100	85	116	120	-	140	126	177	53	123	189	244	253	253	95	13	18	20
	MR V	MR 2I, 3I	40	63	32	-	75			30	2)	211	67		13	100	4)	-	3	160	140	95	204	39	123	189	244	467	522	95	18	23	25
	MR IV	MR 2I, 3I	32	63								211			12	100				160	160		204		138	216	278	494	556	112	18	25	28
63	R V	MR V	32	63	63	50	102	83,5	32	19	M8	76	125	58,5	11,5	100	80	129	120	-	140	151	205	63	123	189	244	279	279	95	18	23	25
	MR V	MR 2I, 3I	40	63	32	-	90			30		231	80		16	100			3	160	140	114	230 <sup>5)</sup>	39	123	189	244	500	555	95	23	28	30
	MR IV	MR 2I, 3I	32	63								231			14	100				160	160		224 <sup>5)</sup>		138	216	278	527	589	112	23	30	33
80	R V	MR V	40	63	80	50	132	103	38	24	M10	87	150	69,5	14	130	110	153	160	-	140	189	250	75	123	189	244	323	323	95	31	36	38
	MR V	MR 2I, 3I	50	63	40	-	106			36		87	100		20	130			3,5	-	160	135	250	46	138	216	278	333	333	112	31	38	41
	MR IV	MR 2I, 3I	40	63								87			17	130				200	140		286		123	189	244	571	626	95	39	44	46
81	R V	MR V	40	63	80	50	132	103	38	24	M10	87	150	69,5	14	130	110	153	160	-	140	189	250	75	123	189	244	323	323	95	31	36	38
	MR V	MR 2I, 3I	50	63	40	-	106			36		87	100		20	130			3,5	-	160	135	250	46	138	216	278	333	333	112	31	38	41
	MR IV	MR 2I, 3I	40	63								87			17	130				200	140		286		123	189	244	571	626	95	39	44	46
100	R V	MR V	50	63	100	63	180	130	48	28	M12	98	180	84,5	16	165	130	187	200	-	140	236	305	90	123	189	244	429	429	95	54	59	61
	MR V	MR 2I, 3I	63	71	50	40	131			42		89	125		23	165			3,5	-	160	165	305	53	138	216	278	439	439	112	55	62	65
	MR IV	MR 2I, 3I	50	63								98			-	165				200	200		305		156	233	302	459	459	121	56	68	71
125	R V	MR V	63	71	125	80	225	155	60	32	M12 <sup>3)</sup>	118	225	99,5	18	215	180	222	250	-	160	287	375	106	138	216	278	515	515	112	90	97	100
	MR V	MR 2I, 3I	63	71	63	50	115			58		118	150		28	215			4	-	200	194	375	63	156	233	302	535	535	121	91	103	106
	MR IV	MR 2I, 3I	63	71								118			-	215				250	200		375		176	287	366	535	535	141	91	108	114
160	R V	MR V	80	71	160	100	272	187	70	38	M14 <sup>3)</sup>	138	280	118,5	22	265	230	268	300	-	160	345	460	125	138	216	278	593	593	112	156	163	166
	MR V	MR 2I, 3I	80	80	80	50	183			58		138	180		33	265			4	-	200	232	460	75	156	233	302	613	613	121	157	169	172
	MR IV	MR 2I, 3I	80	80								138			-	265				250	200		460		176	287	366	613	613	141	157	174	180
161	R V	MR V	80	71	160	100	272	187	70	38	M14 <sup>3)</sup>	138	280	118,5	22	265	230	268	300	-	160	345	460	125	138	216	278	593	593	112	156	163	166
	MR V	MR 2I, 3I	80	80	80	50	183			58		138	180		33	265			4	-	200	232	460	75	156	233	302	613	613	121	157	169	172
	MR IV	MR 2I, 3I	80	80								138			-	265				250	200		460		176	287	366	613	613	141	157	174	180
200	R V	MR V	100	80	200	100	342	235	90	48	M16 <sup>3)</sup>	170	335	137,5	27,5	300	250	328	350	-	200	431	560	150	156	233	302	745	745	121	280	292	295
	MR V	MR 2I, 3I	100	90	100	63	214			82		170	225		40	300			5	-	200	270	560	90	176	287	366	745	745	141	280	297	303
	MR IV	MR 2I, 3I	100	90								170			-	300				250	200		560		194	310	405	770	770	151	281	304	308
250	R V	MR V	125	90	250	125	425	287	110	55	M16 <sup>3)</sup>	205	410	163	33	400	350	401	450	-	200	537	690	180	176	287	366	876	876	141	462	481	487
	MR V	MR 2I, 3I	100	90	250	80	250			82	3)	205	280		50	400			5	-	250	320	690	106	194	310	405	895	895	151	465	488	492
	MR IV	MR 2I, 3I	100	90								205			-	400				250	200		690		218	336	435	895	895	163	465	500	507

1) Working length of thread 2 · F.

2) Holes turned through 45° with respect to the drawing.

3) Holes turned through 22° 30' with respect to the drawing.

4) Tolerance t8.

5) Highest value is valid for MR V.

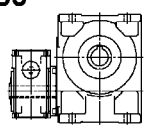
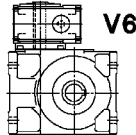
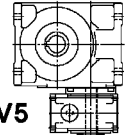
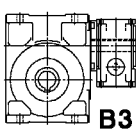
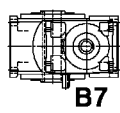
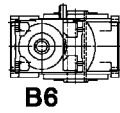
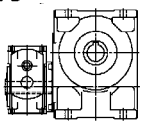
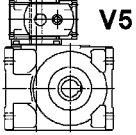
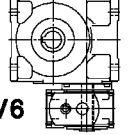
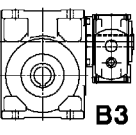
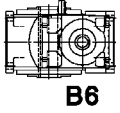
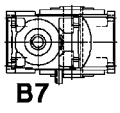
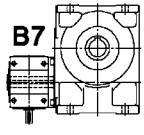
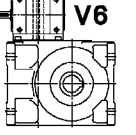
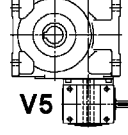
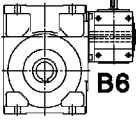
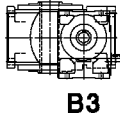
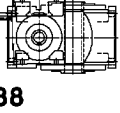
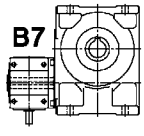
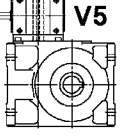
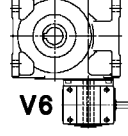
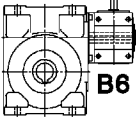
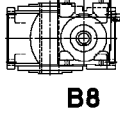
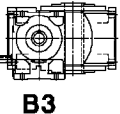
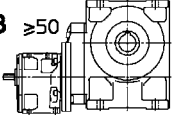
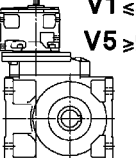
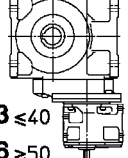
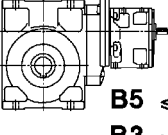
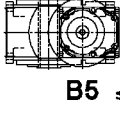
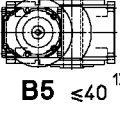
6) Values valid for brake motor.

7) Values valid for gearmotor without motor.

## Initial gear reducer or gearmotor mounting position

In order to make easier the individualization of the combined gear reducer and gearmotor mounting position refer to following table where, according to the final gear reducer mounting position and to the initial gear reducer or gearmotor coupling position, the mounting positions of the same initial gear reducer or gearmotor are stated.

### Initial gear reducer mounting position

Coupling position	Final gear reducer mounting position					
	B3	B6	B7	B8	V5	V6
–	RV ... + RV ...		RV ... + RIV ...			
	<b>B8</b> 	 <b>V6</b>	 <b>V5</b>	 <b>B3</b>	 <b>B7</b>	 <b>B6</b>
1	RV ... + RV ...		RV ... + RIV ...			
	<b>B8</b> 	 <b>V5</b>	 <b>V6</b>	 <b>B3</b>	 <b>B6</b>	 <b>B7</b>
2	RV ... + RV ...		RV ... + RIV ...			
	 <b>B7</b>	 <b>V6</b>	 <b>V5</b>	 <b>B6</b>	 <b>B3</b>	 <b>B8</b>
3	RV ... + RV ...		RV ... + RIV ...			
	 <b>B7</b>	 <b>V5</b>	 <b>V6</b>	 <b>B6</b>	 <b>B8</b>	 <b>B3</b>
	MR V ... + R 2I, 3I ...		MR IV ... + R 2I, 3I ...			
	<b>B5</b> ≤40 <b>B3</b> ≥50 	<b>V1</b> ≤40 <b>V5</b> ≥50 	<b>V3</b> ≤40 <b>V6</b> ≥50 	 <b>B5</b> ≤40 <b>B3</b> ≥50	 <b>B5</b> ≤40 <sup>1)</sup> <b>B6</b> ≥50	 <b>B5</b> ≤40 <sup>1)</sup> <b>B7</b> ≥50

<sup>1)</sup> Grease quantity is the same foreseen for B3 mounting position of cat. E.  
On name plate there is a \* in correspondence of mounting position.

Initial **gearmotor** mounting position<sup>2)</sup>

Coupling position	Final gear reducer mounting position					
	B3	B6	B7	B8	V5	V6
—	R V ... + MR V ...		R V ... + MR IV ...			
1	R V ... + MR V ...		R V ... + MR IV ...			
2	R V ... + MR V ...		R V ... + MR IV ...			
3	R V ... + MR V ...		R V ... + MR IV ...			
	MR V ... + MR 2I, 3I ...		MR IV ... + MR 2I, 3I ...			

1) Grease quantity is the same foreseen for B3 mounting position of cat. E.  
 On name plate there is a \* in correspondence of mounting position.  
 1) For initial worm gearmotor the motor terminal box position is always in TB3 position see ch. 3.1).

## Radial loads<sup>1)</sup> $F_{r1}$ [daN] on high speed shaft end 3.11

Radial loads generated on the shaft end by a drive connecting gear reducer and motor must be less than or equal to those given in the relevant table.

The radial load  $F_{r1}$  given by the following formula refers to most common drives:

$$F_{r1} = \frac{2\,865 \cdot P_1}{d \cdot n_1} \text{ [daN]} \quad \text{for timing belt drive}$$

$$F_{r1} = \frac{4\,775 \cdot P_1}{d \cdot n_1} \text{ [daN]} \quad \text{for V-belt drive}$$

where:  $P_1$  [kW] is power required at the input side of the gear reducer,  $n_1$  [ $\text{min}^{-1}$ ] is the speed,  $d$  [m] is the pitch diameter.

Radial loads given in the table are valid for overhung loads on centre line of high speed shaft end, i.e. operating at a distance of  $0,5 \cdot e$  ( $e$  = shaft end length) from the shoulder. If they operate at  $0,315 \cdot e$  multiply by 1,25; if they operate at  $0,8 \cdot e$  multiply by 0,8.

$n_1$ $\text{min}^{-1}$	Gear reducer size																			
	32		40		50		63, 64		80, 81		100		125, 126		160, 161		200		250	
	R V	R IV	R V	R IV	R V	R IV	R V	R IV	R V	R IV	R V	R IV	R V	R IV	R V	R IV	R V	R IV	R V	R IV
1 400	14	11,2	21,2	17	31,5	17	47,5	26,5	71	26,5	106	42,5	160	75	236	170	265	170	375	250
1 120	15	11,8	22,4	18	33,5	18	50	28	75	28	112	45	170	80	250	180	280	180	400	265
900	16	12,5	23,6	19	35,5	19	53	30	80	30	118	47,5	180	85	265	190	300	190	425	280
710	18	14	26,5	21,2	40	21,2	60	33,5	90	33,5	132	53	200	95	300	212	335	212	475	315
560	19	15	28	22,4	42,5	22,4	63	35,5	95	35,5	140	56	212	100	315	224	355	224	500	335
450	20	16	30	23,6	45	23,6	67	37,5	100	37,5	150	60	224	106	335	236	375	236	530	355
355	22,4	18	33,5	26,5	50	26,5	75	42,5	112	42,5	170	67	250	118	375	265	425	265	600	400

1) An axial load of up to 0,2 times the value in the table is permissible, simultaneously with the radial load. If exceeded consult us.

## Radial $F_{r2}$ or axial loads $F_{a2}$ [daN] on low speed shaft end 3.12

### Axial loads $F_{a2}$

Permissible  $F_{a2}$  is shown in the column where direction of rotation of low speed shaft (black or white arrow) and direction of the axial force (solid or broken arrow) correspond to those of the gear reducer in question. Direction of rotation and direction of force may be established viewing the gear reducer from any point, providing the same point adopted for both.

Wherever possible, choose the load conditions corresponding the column on the **right**

### Radial loads $F_{r2}$

Radial loads generated on the shaft end by a drive connecting gear reducer and machine must be less than or equal to those given in the relevant table.

Normally, radial loads on low speed shaft ends are considerable: in fact there is a tendency to connect the gear reducer to the machine by means of a transmission with high transmission ratio (economizing on the gear reducer) and with small diameters (economizing on the drive, and for requirements dictated by overall dimensions).

Bearing life and wear (which also affect gears unfavourably) and low speed shaft strength, clearly impose limits on permissible radial load.

The high value which radial load may take on, and the importance of not exceeding permissible values, make it necessary to take full advantage of the gear reducer's possibilities.

Permissible radial loads given in the table are therefore based on: the product of speed  $n_2$  [ $\text{min}^{-1}$ ] multiplied by bearing life  $L_n$  [h] required, the direction of rotation, the angular position  $\varphi$  [ $^\circ$ ] of the load and torque  $M_2$  [daN m] required.

Radial loads given in the table are valid for overhung loads on centre line of low speed shaft end, i.e. operating at a distance of  $0,5 \cdot E$  ( $E$  = shaft end length) from the shoulder. If operating at  $0,315 \cdot E$  multiply by 1,25; if operating at  $0,8 \cdot E$  multiply by 0,8.

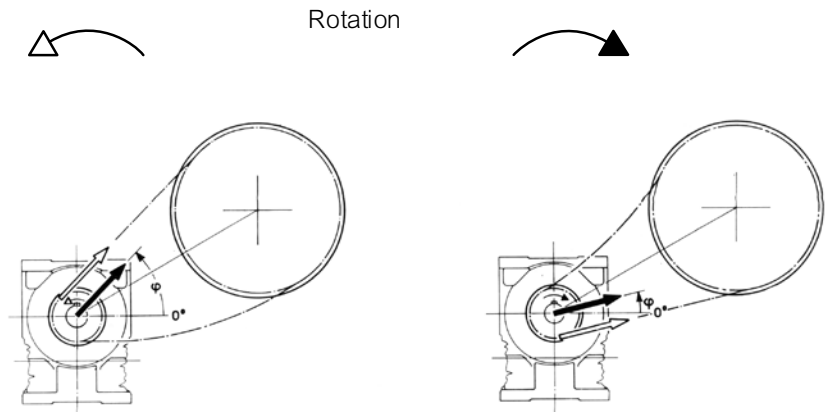


# Radial $F_{r2}$ or axial loads $F_{a2}$ [daN] on low speed shaft end 3.12

Radial load  $F_{r2}$  for most common drives has the following value and angular position:

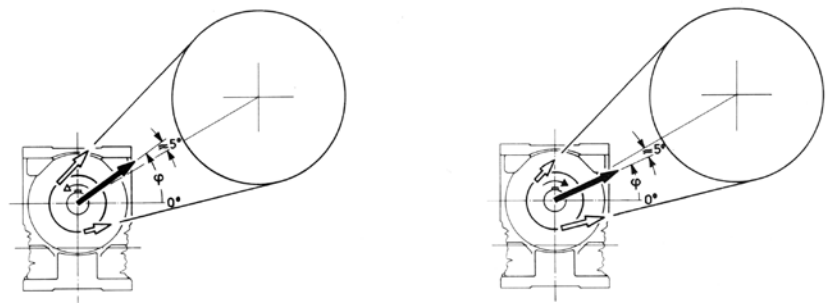
$$F_{r2} = \frac{1\,910 \cdot P_2}{d \cdot n_2} \text{ [daN]}$$

for chain drive (lifting in general); for timing belt drive replace 1 910 with 2 865



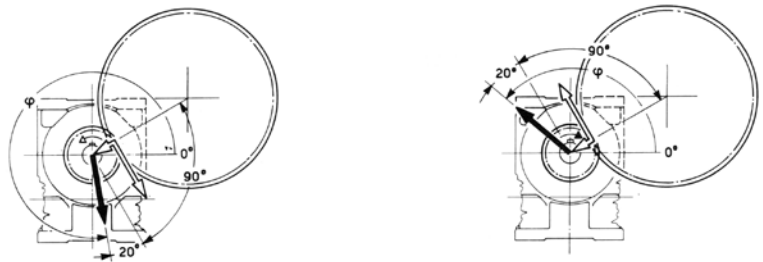
$$F_{r2} = \frac{4\,775 \cdot P_2}{d \cdot n_2} \text{ [daN]}$$

for V-belt drive



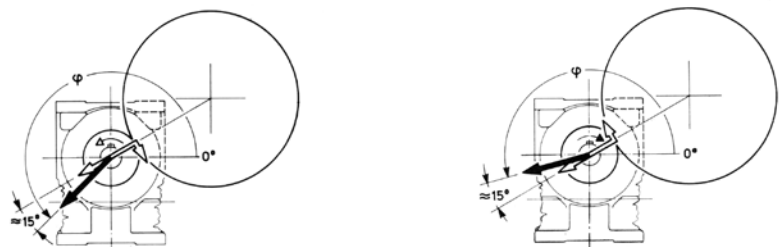
$$F_{r2} = \frac{2\,032 \cdot P_2}{d \cdot n_2} \text{ [daN]}$$

for spur gear pair drive



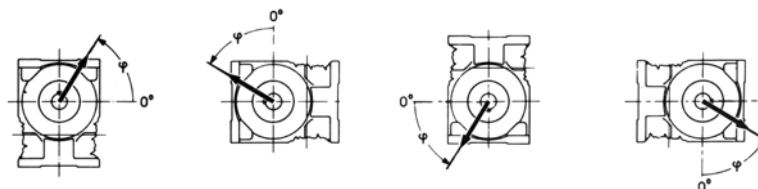
$$F_{r2} = \frac{6\,781 \cdot P_2}{d \cdot n_2} \text{ [daN]}$$

for friction wheel drive (rubber-on-metal)



where:  $P_2$  [kW] is power required at the output side of the gear re-ducer,  $n_2$  [ $\text{min}^{-1}$ ] is the speed,  $d$  [m] is the pitch diameter.

**IMPORTANT:**  $0^\circ$  coincides with a half line lying parallel to the worm axis, and oriented as shown above, and therefore it follows the rotation of the worm axis as shown below.



# Radial $F_{r2}$ or axial loads $F_{a2}$ [daN] on low speed shaft end 3.12

size **32**

$n_2 \cdot L_h$ min <sup>-1</sup> · h	$M_2$ daN m	$F_{r2}^{1)}$															$F_{a2}^{2)}$		
		0	45	90	135	180	225	270	315	0	45	90	135	180	225	270	315	80	125
<b>355 000</b>	5,3	180	180	180	180	180	180	180	180	180	180	180	180	180	180	180	180	80	125
<b>710 000</b>	3,75 2,65	140	150	170	180	180	180	180	160	180	180	150	132	140	170	180	180	80	125
<b>900 000</b>	3,75 2,65 1,9	125	132	160	180	180	180	170	140	180	180	140	125	125	150	180	180	80	125
<b>1 120 000</b>	2,65 1,9 1,32	125	132	150	180	180	180	160	140	180	170	140	125	125	150	170	180	80	112
<b>1 400 000</b>	2,65 1,9 1,32	118	118	140	160	180	170	150	125	180	150	125	112	118	135	160	180	80	106
<b>1 800 000</b>	2,65 1,9 1,32	106	106	125	150	170	160	140	118	170	140	118	100	106	125	150	170	71	95
<b>2 240 000</b>	2,65 1,9 1,32	95	100	118	140	160	150	132	106	160	132	106	90	95	112	140	160	63	85
<b>2 800 000</b>	2,65 1,9 1,32	85	90	106	132	150	140	118	95	150	125	95	80	85	100	132	150	56	75
<b>3 550 000</b>	1,9 1,32 0,95	85	90	100	118	132	125	112	95	132	112	95	85	85	100	118	132	56	71
<b>max 180</b>																	<b>max 80</b>	<b>max 125</b>	

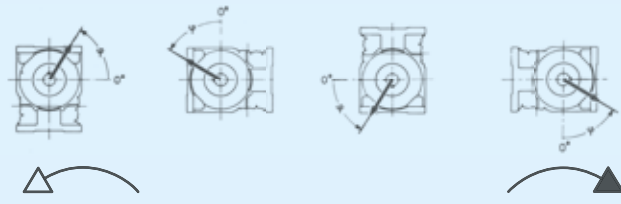
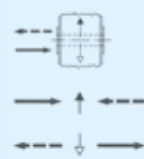
size **40**

<b>224 000</b>	9	250	250	250	250	250	250	250	250	250	250	250	250	250	250	250	250	112	180
<b>450 000</b>	6,3 4,5	200	200	236	250	250	250	250	224	250	250	212	190	200	236	250	250	112	180
<b>560 000</b>	6,3 4,5 3,15	180	190	224	250	250	250	250	200	250	250	200	170	180	212	250	250	112	180
<b>710 000</b>	6,3 4,5 3,15	160	170	200	250	250	250	224	180	250	236	180	150	160	190	250	250	112	160
<b>900 000</b>	6,3 4,5 3,15	140	150	190	236	250	250	212	160	250	212	160	140	140	180	236	250	106	140
<b>1 120 000</b>	4,5 3,15 2,24	150	150	180	212	236	224	190	160	236	200	160	140	150	170	212	236	106	132
<b>1 400 000</b>	4,5 3,15 2,24	132	140	160	200	224	212	180	150	224	180	150	132	132	160	200	224	95	118
<b>1 800 000</b>	4,5 3,15 2,24	118	125	150	190	212	200	170	132	200	170	132	112	118	140	180	212	80	106
<b>2 240 000</b>	4,5 3,15 2,24	106	112	140	170	200	190	150	125	190	160	118	106	106	132	170	200	71	95
<b>2 800 000</b>	4,5 3,15 2,24	100	100	125	160	190	180	140	112	180	150	112	90	95	118	160	190	60	90
<b>3 550 000</b>	3,15 2,24 1,6	100	106	125	150	160	150	132	112	160	132	112	95	100	118	140	160	63	80
<b>max 250</b>																	<b>max 112</b>	<b>max 180</b>	

1) An axial load of up to 0,2 times the value in the table is permissible, simultaneously with the radial load. If exceeded consult us.  
2) A radial load of up to 0,2 times the value in the table is permissible, simultaneously with the axial load. If exceeded consult us.

# Radial $F_{r2}$ or axial loads $F_{a2}$ [daN] on low speed shaft end 3.12

size **50**

$n_2 \cdot L_n$	$M_2$	$F_{r2}^{1)}$												$F_{a2}^{2)}$					
																			
min <sup>-1</sup> · h	daN · m	0	45	90	135	180	225	270	315	0	45	90	135	180	225	270	315		
<b>140 000</b>	25	335	355	355	355	355	355	355	355	355	355	355	315	315	355	355	355	160	250
	18	355	355	355	355	355	355	355	355	355	355	355	355	355	355	355	355	160	250
	12,5	355	355	355	355	355	355	355	355	355	355	355	355	355	355	355	355	160	250
<b>180 000</b>	18	300	315	355	355	355	355	355	335	355	355	335	280	280	355	355	355	160	250
	12,5	335	355	355	355	355	355	355	355	335	355	355	315	335	355	355	355	160	250
	9	355	355	355	355	355	355	355	355	355	355	355	355	355	355	355	355	160	250
<b>224 000</b>	18	265	280	355	355	355	355	355	300	355	355	300	250	250	335	355	355	160	250
	12,5	300	315	355	355	355	355	355	335	355	355	335	300	300	355	355	355	160	250
	9	335	335	355	355	355	355	355	355	355	355	355	315	335	355	355	355	160	250
<b>280 000</b>	12,5	280	280	335	355	355	355	355	315	355	355	300	265	265	335	355	355	160	250
	9	300	315	355	355	355	355	355	335	355	355	335	300	300	335	355	355	160	250
	6,3	250	265	315	355	355	355	355	280	355	355	280	236	250	300	355	355	160	250
<b>355 000</b>	12,5	280	280	335	355	355	355	355	300	355	355	300	265	265	335	355	355	160	250
	9	300	300	335	355	355	355	355	315	355	355	315	280	300	335	355	355	160	250
	6,3	224	236	280	355	355	355	315	250	355	335	250	212	212	265	355	355	160	236
<b>450 000</b>	12,5	250	265	300	355	355	355	315	265	355	335	265	236	250	280	355	355	160	250
	9	265	280	315	335	355	355	315	280	355	335	280	265	265	300	335	355	160	250
	6,3	280	280	315	335	355	355	315	300	355	335	300	280	280	300	335	355	160	250
<b>560 000</b>	12,5	200	212	265	335	355	355	300	224	355	300	224	190	200	250	335	355	150	212
	9	224	236	280	335	355	355	300	250	355	300	250	212	224	265	335	355	160	224
	6,3	250	250	280	315	335	335	300	265	335	300	265	236	250	280	315	355	160	236
<b>710 000</b>	12,5	265	265	280	315	335	315	300	280	335	300	280	250	265	280	315	335	160	236
	9	180	190	236	315	355	355	265	200	355	280	200	160	170	224	315	355	132	190
	6,3	200	212	250	315	335	335	280	224	335	280	224	200	200	236	300	355	160	200
<b>900 000</b>	12,5	224	236	265	300	315	315	280	236	315	280	236	224	224	250	300	335	160	212
	9	236	250	265	300	315	300	280	250	315	280	250	236	236	265	280	315	160	212
	6,3	160	170	224	300	355	315	250	180	335	250	180	140	150	200	280	355	112	170
<b>1 120 000</b>	12,5	180	190	236	280	315	300	250	200	315	265	200	170	180	224	280	335	140	180
	9	200	212	236	280	300	280	250	224	300	265	224	200	200	236	280	315	160	190
	6,3	224	224	250	265	280	280	250	236	280	265	236	212	212	236	265	280	160	190
<b>1 400 000</b>	12,5	170	170	212	265	300	280	236	190	300	236	180	160	160	200	265	315	118	160
	9	190	190	224	265	280	280	236	200	280	236	200	180	190	212	265	280	140	170
	6,3	200	200	224	250	265	265	236	212	265	236	212	200	200	224	250	280	150	180
<b>1 800 000</b>	12,5	150	160	200	250	280	265	212	170	280	224	170	140	140	180	250	300	100	150
	9	170	180	200	250	265	250	224	190	265	224	180	160	170	200	236	265	125	160
	6,3	180	190	212	236	250	250	224	200	250	224	200	180	180	200	236	250	132	160
<b>2 240 000</b>	12,5	132	140	180	236	265	250	200	150	265	200	150	125	125	160	224	280	85	132
	9	150	160	190	224	250	236	200	170	250	212	170	150	150	180	224	250	106	140
	6,3	170	170	190	224	236	224	200	180	236	212	180	160	160	190	224	236	118	140
<b>2 800 000</b>	12,5	118	125	160	224	250	236	180	140	250	190	132	106	112	150	212	265	75	118
	9	140	140	170	212	236	224	190	150	236	190	150	132	132	160	212	236	95	125
	6,3	150	160	180	200	224	212	190	160	224	190	160	150	150	170	200	224	106	132
<b>3 550 000</b>	12,5	106	112	150	200	236	224	170	125	236	180	118	95	100	132	200	250	63	106
	9	125	132	160	200	224	212	170	140	224	180	140	118	125	150	200	224	80	112
	6,3	140	140	160	190	212	200	170	150	212	180	150	132	140	160	190	212	95	118
<b>3 550 000</b>	4,5	150	150	170	190	200	190	180	160	200	180	160	150	150	160	190	200	100	118
	3,15	112	118	140	180	212	200	160	125	200	160	125	106	112	140	180	212	71	100
	1,5	125	132	150	180	200	190	160	140	190	170	132	118	125	140	180	200	85	106
		132	140	150	170	180	180	160	140	180	170	140	132	132	150	170	190	90	106
<b>max 355</b>																	<b>max 160</b>	<b>max 250</b>	

1) An axial load of up to 0,2 times the value in the table is permissible, simultaneously with the radial load. If exceeded consult us.  
 2) A radial load of up to 0,2 times the value in the table is permissible, simultaneously with the axial load. If exceeded consult us.

# Radial $F_{r2}$ or axial loads $F_{a2}$ [daN] on low speed shaft end 3.12

size **63, 64**

$n_2 \cdot L_h$ min <sup>-1</sup> · h	$M_2$ daN m	$F_{r2}^{1)}$												$F_{a2}^{2)}$					
		0	45	90	135	180	225	270	315	0	45	90	135	180	225	270	315	236	375
<b>90 000</b>	47,5	400	425	530	530	530	530	530	475	530	530	450	355	375	530	530	530	236	375
	33,5	475	500	530	530	530	530	530	530	530	530	530	450	475	530	530	530	236	375
<b>112 000</b>	33,5	425	450	530	530	530	530	530	500	530	530	475	400	425	530	530	530	236	375
	23,6	500	500	530	530	530	530	530	530	530	530	530	475	475	530	530	530	236	375
<b>140 000</b>	33,5	375	425	530	530	530	530	530	450	530	530	425	355	375	475	530	530	236	375
	23,6	450	475	530	530	530	530	530	500	530	530	475	425	450	530	530	530	236	375
<b>180 000</b>	33,5	335	375	475	530	530	530	530	400	530	530	375	315	335	425	530	530	236	375
	23,6	400	425	500	530	530	530	530	450	530	530	425	375	400	475	530	530	236	375
<b>224 000</b>	33,5	300	335	425	530	530	530	475	355	530	500	335	280	280	400	530	530	236	375
	23,6	355	375	450	530	530	530	500	400	530	500	400	335	355	425	530	530	236	375
<b>280 000</b>	33,5	280	315	375	500	530	530	425	335	530	425	315	265	280	355	500	530	236	315
	23,6	335	335	400	475	530	500	425	355	530	450	355	315	315	375	475	530	236	335
<b>355 000</b>	33,5	250	280	355	475	530	500	400	300	530	400	280	236	250	315	450	530	200	280
	23,6	300	315	375	450	500	475	400	335	500	400	315	280	280	355	450	500	236	300
<b>450 000</b>	33,5	250	280	355	475	530	500	400	300	530	400	280	236	250	315	450	530	200	280
	23,6	300	315	375	450	500	475	400	335	500	400	315	280	280	355	450	500	236	300
<b>560 000</b>	33,5	250	280	355	475	530	500	400	300	530	400	280	236	250	315	450	530	200	280
	23,6	300	315	375	450	500	475	400	335	500	400	315	280	280	355	450	500	236	300
<b>710 000</b>	33,5	250	280	355	475	530	500	400	300	530	400	280	236	250	315	450	530	200	280
	23,6	300	315	375	450	500	475	400	335	500	400	315	280	280	355	450	500	236	300
<b>900 000</b>	33,5	250	280	355	475	530	500	400	300	530	400	280	236	250	315	450	530	200	280
	23,6	300	315	375	450	500	475	400	335	500	400	315	280	280	355	450	500	236	300
<b>1 120 000</b>	33,5	250	280	355	475	530	500	400	300	530	400	280	236	250	315	450	530	200	280
	23,6	300	315	375	450	500	475	400	335	500	400	315	280	280	355	450	500	236	300
<b>1 400 000</b>	33,5	250	280	355	475	530	500	400	300	530	400	280	236	250	315	450	530	200	280
	23,6	300	315	375	450	500	475	400	335	500	400	315	280	280	355	450	500	236	300
<b>1 800 000</b>	33,5	250	280	355	475	530	500	400	300	530	400	280	236	250	315	450	530	200	280
	23,6	300	315	375	450	500	475	400	335	500	400	315	280	280	355	450	500	236	300
<b>2 240 000</b>	33,5	250	280	355	475	530	500	400	300	530	400	280	236	250	315	450	530	200	280
	23,6	300	315	375	450	500	475	400	335	500	400	315	280	280	355	450	500	236	300
<b>2 800 000</b>	33,5	250	280	355	475	530	500	400	300	530	400	280	236	250	315	450	530	200	280
	23,6	300	315	375	450	500	475	400	335	500	400	315	280	280	355	450	500	236	300
<b>3 550 000</b>	33,5	250	280	355	475	530	500	400	300	530	400	280	236	250	315	450	530	200	280
	23,6	300	315	375	450	500	475	400	335	500	400	315	280	280	355	450	500	236	300

max **530**

max **236**

max **375**

1) An axial load of up to 0,2 times the value in the table is permissible, simultaneously with the radial load. If exceeded consult us.  
 2) A radial load of up to 0,2 times the value in the table is permissible, simultaneously with the axial load. If exceeded consult us.

# Radial $F_{r2}$ or axial loads $F_{a2}$ [daN] on low speed shaft end 3.12

size **80, 81**

$n_2 \cdot L_n$	$M_2$	$F_{r2}^{1)}$												$F_{a2}^{2)}$						
$\text{min}^{-1} \cdot \text{h}$	daN m	0	45	90	135	180	225	270	315	0	45	90	135	180	225	270	315	355	560	
<b>90 000</b>	80	560	630	800	800	800	800	800	800	670	800	800	670	670	560	750	800	800	355	560
	56	710	750	800	800	800	800	800	800	800	800	800	800	800	670	800	800	800	355	560
<b>112 000</b>	56	630	670	800	800	800	800	800	800	710	800	800	710	600	630	750	800	800	355	560
	40	710	750	800	800	800	800	800	800	750	800	800	750	670	710	800	800	800	355	560
<b>140 000</b>	56	560	600	750	800	800	800	800	800	630	800	800	630	530	560	710	800	800	355	560
	40	630	670	800	800	800	800	800	800	710	800	800	710	630	630	750	800	800	355	560
	28	710	710	800	800	800	800	800	800	750	800	800	750	670	710	800	800	800	355	560
<b>180 000</b>	56	500	530	670	800	800	800	800	750	560	800	800	560	450	475	630	800	800	355	560
	40	560	600	710	800	800	800	800	750	630	800	800	630	560	560	670	800	800	355	560
	28	630	670	750	800	800	800	800	750	670	800	800	670	630	630	710	800	800	355	560
<b>224 000</b>	56	450	475	630	800	800	800	800	710	530	800	710	500	400	425	560	800	800	335	500
	40	530	560	670	800	800	800	800	710	560	800	750	560	500	500	630	800	800	355	530
	28	560	600	670	800	800	800	800	710	630	800	750	630	560	560	670	800	800	355	560
	20	630	630	710	750	800	800	800	710	670	800	750	630	600	630	670	750	800	355	560
<b>280 000</b>	40	475	500	600	750	800	800	800	670	530	800	670	530	450	450	560	750	800	355	475
	28	530	560	630	750	800	750	670	560	800	670	560	500	530	600	750	800	800	355	500
	20	560	600	630	710	750	670	670	600	800	750	670	600	560	560	630	710	750	355	500
<b>355 000</b>	40	425	450	560	710	800	750	600	475	800	630	475	400	400	530	710	800	315	425	
	28	475	500	560	670	750	710	630	530	750	630	530	450	475	560	670	750	800	355	450
	20	530	530	600	670	710	670	630	560	710	630	560	500	500	560	670	710	800	355	450
	14	560	560	600	670	670	670	630	560	800	670	630	560	530	560	600	630	670	355	475
<b>450 000</b>	40	375	400	500	670	750	710	560	425	750	560	425	335	355	475	630	800	265	375	
	28	425	450	530	630	710	670	560	475	710	600	475	400	425	500	630	710	315	400	
	20	475	500	560	630	670	630	560	500	670	600	500	450	475	530	630	670	355	425	
	14	500	500	560	600	630	630	560	530	800	630	570	530	500	500	530	600	630	355	425
<b>560 000</b>	40	335	355	475	630	710	670	530	375	710	530	375	300	315	425	600	750	224	355	
	28	400	400	500	600	670	630	530	425	670	530	425	375	375	475	600	670	280	355	
	20	425	450	500	560	630	600	530	475	630	530	450	425	425	500	560	630	315	375	
	14	450	475	500	560	600	560	530	475	800	600	530	475	450	450	500	560	600	335	375
<b>710 000</b>	40	300	315	425	560	670	630	475	335	670	500	335	265	280	375	560	710	190	315	
	28	355	375	450	560	630	600	475	400	630	500	375	335	335	425	560	630	250	335	
	20	400	400	475	530	600	560	500	425	560	500	425	375	375	450	530	600	280	335	
	14	425	425	475	530	560	530	500	450	800	560	500	450	400	425	475	530	560	300	355
<b>900 000</b>	40	250	280	375	530	630	600	425	300	630	450	280	224	236	335	530	670	160	280	
	28	315	335	400	530	600	560	450	355	560	450	355	300	315	375	500	600	212	300	
	20	355	375	425	500	560	530	450	375	530	475	375	335	355	400	500	560	250	300	
	14	375	400	425	500	530	500	450	400	800	530	475	400	375	375	425	500	530	265	315
<b>1 120 000</b>	28	280	300	375	500	560	530	425	315	560	425	315	265	280	355	475	560	180	265	
	20	315	335	400	475	530	500	425	355	500	425	355	315	315	355	475	530	212	280	
	14	355	355	400	450	500	475	425	375	475	425	375	335	355	400	450	500	236	280	
<b>1 400 000</b>	28	250	265	355	450	530	500	375	280	530	400	280	236	250	315	450	530	160	236	
	20	300	315	355	450	475	450	400	315	475	400	315	280	280	355	425	500	190	250	
	14	315	335	375	425	450	450	400	335	450	400	335	315	315	355	425	475	212	250	
<b>1 800 000</b>	28	224	236	315	425	500	450	355	250	475	355	250	200	212	280	400	500	132	212	
	20	265	280	335	400	450	425	355	280	450	355	280	250	250	315	400	475	160	224	
	14	280	300	335	400	425	400	355	315	425	375	315	280	280	335	400	425	190	224	
	10	315	315	355	375	400	400	355	335	400	375	315	300	315	335	375	400	200	236	
<b>2 240 000</b>	20	236	250	300	375	425	400	335	265	425	335	265	224	236	280	375	450	140	200	
	14	265	280	315	375	400	375	335	280	400	335	280	250	265	300	375	400	170	212	
	10	280	300	315	355	375	375	335	300	375	335	300	280	280	315	355	375	180	212	
<b>2 800 000</b>	20	212	224	280	355	400	375	300	236	400	315	236	200	212	265	355	425	125	180	
	14	236	250	300	355	375	355	315	255	375	315	265	236	236	280	335	375	150	190	
	10	265	265	300	335	355	355	315	280	355	315	280	250	265	280	335	355	160	190	
<b>3 550 000</b>	20	190	200	250	335	375	355	280	212	375	280	212	170	180	236	335	400	106	160	
	14	212	224	265	315	355	335	280	236	355	300	236	212	212	250	315	355	125	170	
	10	236	250	280	300	335	315	280	250	335	300	250	236	236	265	315	335	140	170	
max <b>800</b>																		max <b>355</b>	max <b>560</b>	

1) An axial load of up to 0,2 times the value in the table is permissible, simultaneously with the radial load. If exceeded consult us.  
 2) A radial load of up to 0,2 times the value in the table is permissible, simultaneously with the axial load. If exceeded consult us.

# Radial $F_{r2}$ or axial loads $F_{a2}$ [daN] on low speed shaft end **3.12**

size **100**

$n_2 \cdot L_h$ min <sup>-1</sup> · h	$M_2$ daN m	$F_{r2}^{1)}$												$F_{a2}^{2)}$					
		0	45	90	135	180	225	270	315	0	45	90	135	180	225	270	315	530	900
<b>90 000</b>	160	670	750	1060	1250	1250	1250	1180	800	1250	1250	750	560	630	900	1250	1250	530	900
	112	850	900	1180	1250	1250	1250	1250	1000	1250	1250	950	800	850	1000	1250	1250	560	900
<b>112 000</b>	112	750	800	1060	1250	1250	1250	1180	900	1250	1180	850	710	750	950	1250	1250	560	900
	80	900	950	1120	1250	1250	1250	1180	1000	1250	1250	950	850	850	1060	1250	1250	560	900
	56	1000	1000	1120	1250	1250	1250	1180	1060	1250	1250	1060	950	950	1120	1250	1250	560	900
	40	1060	1060	1180	1250	1250	1250	1180	1120	1250	1250	1060	1000	1060	1120	1250	1250	560	900
<b>140 000</b>	112	670	750	950	1250	1250	1250	1060	800	1250	1120	750	630	630	900	1250	1250	530	800
	80	800	850	1000	1250	1250	1250	1120	900	1250	1120	900	750	800	950	1250	1250	560	850
	56	900	950	1060	1250	1250	1250	1120	950	1250	1120	950	850	900	1000	1250	1250	560	900
	40	950	1000	1060	1180	1250	1250	1120	1000	1250	1120	1000	950	950	1060	1180	1250	560	900
<b>180 000</b>	112	600	630	850	1250	1250	1250	1000	710	1250	1000	670	530	560	800	1180	1250	450	710
	80	710	750	950	1180	1250	1250	1000	800	1250	1060	800	670	710	850	1180	1250	560	750
	56	800	850	950	1120	1250	1180	1000	850	1250	1060	850	750	800	950	1120	1250	560	800
	40	850	900	1000	1120	1180	1120	1000	900	1180	1060	900	850	850	950	1120	1180	560	800
<b>224 000</b>	112	530	560	800	1120	1250	1180	900	630	1250	950	600	450	475	710	1120	1250	375	630
	80	630	670	850	1120	1250	1180	950	710	1250	950	710	600	630	800	1060	1250	500	670
	56	750	750	900	1060	1180	1120	950	800	1180	1000	800	710	710	850	1060	1180	560	710
	40	800	800	900	1060	1120	1060	950	850	1120	1000	850	750	800	900	1000	1120	560	750
<b>280 000</b>	80	560	630	800	1060	1180	1120	850	670	1180	900	630	530	560	710	1000	1250	425	600
	56	670	710	800	1000	1120	1060	900	750	1060	900	710	630	670	800	1000	1120	500	630
	40	710	750	850	950	1000	1000	900	750	1000	900	750	710	710	800	950	1060	560	670
<b>335 000</b>	80	500	560	710	950	1120	1060	800	600	1120	800	560	450	500	630	950	1180	355	560
	56	600	630	750	950	1000	950	800	670	1000	850	670	560	600	710	900	1060	450	560
	40	670	670	800	900	950	950	800	710	950	850	710	630	670	750	900	1000	500	600
<b>450 000</b>	80	450	475	630	900	1060	950	710	530	1060	750	500	400	425	560	850	1120	300	475
	56	530	560	710	850	950	900	750	600	950	750	600	500	530	670	850	1000	375	530
	40	600	630	710	850	900	850	750	630	900	750	630	560	600	670	850	900	425	530
	28	630	670	710	800	850	850	750	670	850	750	670	630	630	710	800	850	475	560
<b>560 000</b>	80	400	425	600	850	950	900	670	475	1000	670	450	355	375	530	800	1060	250	450
	56	475	530	630	800	900	850	710	560	900	710	530	450	475	600	800	950	335	475
	40	560	560	670	800	850	800	710	600	850	710	600	530	530	630	750	850	400	475
	28	600	600	670	750	800	800	710	630	800	710	630	560	600	670	750	800	425	500
<b>710 000</b>	56	425	450	560	750	850	800	630	500	850	670	475	400	425	530	750	900	280	425
	40	500	530	600	710	800	750	630	530	800	670	530	475	475	560	710	800	335	425
	28	530	560	630	710	750	710	630	560	750	670	560	530	530	600	710	750	375	450
<b>900 000</b>	56	375	400	530	710	800	750	560	450	800	600	425	355	375	475	670	850	250	375
	40	450	475	560	670	750	710	600	500	750	600	475	425	425	530	670	750	300	400
	28	500	500	560	670	710	670	600	530	710	600	530	475	475	560	630	710	335	400
<b>1 120 000</b>	56	335	375	475	670	750	710	530	400	750	560	375	315	315	450	630	800	212	335
	40	400	425	500	630	710	670	560	450	710	560	450	375	400	475	630	710	265	355
	28	450	475	530	600	670	630	560	475	670	560	475	425	450	500	600	670	300	375
<b>1 400 000</b>	56	300	335	450	630	710	670	500	355	710	500	335	265	280	400	600	750	170	300
	40	355	375	475	600	670	630	500	400	670	530	400	335	355	450	600	670	224	315
	28	400	425	500	560	630	600	530	450	630	530	450	400	400	475	560	630	265	335
<b>1 800 000</b>	56	265	280	400	560	630	600	450	315	670	475	300	224	236	355	560	710	140	265
	40	315	335	425	560	630	600	475	355	630	475	355	300	315	400	530	630	190	280
	28	375	375	450	530	560	560	475	400	560	500	400	355	355	425	530	600	236	300
<b>2 240 000</b>	40	280	315	400	530	600	560	425	335	560	450	315	265	280	355	500	600	170	265
	28	335	355	400	500	560	530	450	375	530	450	355	315	335	400	500	560	200	265
<b>2 800 000</b>	40	250	280	355	475	560	530	400	300	560	400	280	236	250	335	475	560	140	235
	28	300	315	375	475	500	500	400	335	500	425	335	280	300	355	450	530	180	255
<b>3 550 000</b>	40	224	250	315	450	530	500	355	265	530	375	250	200	212	300	450	560	118	212
	28	265	280	355	425	475	450	375	300	475	375	300	250	265	335	425	500	150	224

max **1 250**

max **560**

max **900**

1) An axial load of up to 0,2 times the value in the table is permissible, simultaneously with the radial load. If exceeded consult us.  
 2) A radial load of up to 0,2 times the value in the table is permissible, simultaneously with the axial load. If exceeded consult us.

# Radial $F_{r2}$ or axial loads $F_{a2}$ [daN] on low speed shaft end 3.12

size **100 bis<sup>3)</sup>**

$n_2 \cdot L_n$	$M_2$	$F_{r2}^{1)}$															$F_{a2}^{2)}$		
$\text{min}^{-1} \cdot \text{h}$	daN m	0	45	90	135	180	225	270	315	0	45	90	135	180	225	270	315		
<b>≤ 280 000</b>	160	1250	1250	1250	1250	1250	1250	1250	1250	1250	1250	1250	1250	1250	1250	1250	1250	560	900
	112	1250	1250	1250	1250	1250	1250	1250	1250	1250	1250	1250	1250	1250	1250	1250	1250	560	900
<b>355 000</b>	80	1250	1250	1250	1250	1250	1250	1250	1250	1250	1250	1250	1250	1250	1250	1250	1250	560	900
	56	1250	1250	1250	1250	1250	1250	1250	1250	1250	1250	1250	1250	1250	1250	1250	1250	560	900
<b>450 000</b>	80	1250	1250	1250	1250	1250	1250	1250	1250	1250	1250	1250	1250	1250	1250	1250	1250	560	900
	56	1250	1250	1250	1250	1250	1250	1250	1250	1250	1250	1250	1250	1250	1250	1250	1250	560	900
<b>560 000</b>	80	1250	1250	1250	1250	1250	1250	1250	1250	1250	1250	1250	1250	1250	1250	1250	1250	560	900
	56	1250	1250	1250	1250	1250	1250	1250	1250	1250	1250	1250	1250	1250	1250	1250	1250	560	900
<b>710 000</b>	56	1250	1250	1250	1250	1250	1250	1250	1250	1250	1250	1250	1250	1250	1250	1250	1250	560	900
	40	1250	1250	1250	1250	1250	1250	1250	1250	1250	1250	1250	1250	1250	1250	1250	1250	560	900
<b>900 000</b>	56	1250	1250	1250	1250	1250	1250	1250	1250	1250	1250	1250	1250	1250	1250	1250	1250	560	900
	40	1250	1250	1250	1250	1250	1250	1250	1250	1250	1250	1250	1250	1250	1250	1250	1250	560	900
<b>1 120 000</b>	56	1250	1250	1250	1250	1250	1250	1250	1250	1250	1250	1250	1250	1250	1250	1250	1250	560	900
	40	1250	1250	1250	1250	1250	1250	1250	1250	1250	1250	1250	1250	1250	1250	1250	1250	560	900
	28	1250	1250	1250	1250	1250	1250	1250	1250	1250	1250	1250	1250	1250	1250	1250	1250	560	900
<b>1 400 000</b>	56	1180	1250	1250	1250	1250	1250	1250	1250	1250	1250	1250	1180	1180	1250	1250	1250	560	850
	40	1250	1250	1250	1250	1250	1250	1250	1250	1250	1250	1250	1250	1250	1250	1250	1250	560	900
	28	1250	1250	1250	1250	1250	1250	1250	1250	1250	1250	1250	1250	1250	1250	1250	1250	560	900
<b>1 800 000</b>	56	1120	1180	1250	1250	1250	1250	1250	1180	1250	1250	1180	1120	1120	1250	1250	1250	560	800
	40	1180	1250	1250	1250	1250	1250	1250	1250	1250	1250	1250	1180	1180	1250	1250	1250	560	850
	28	1250	1250	1250	1250	1250	1250	1250	1250	1250	1250	1250	1250	1250	1250	1250	1250	560	850
<b>2 240 000</b>	40	1120	1120	1250	1250	1250	1250	1250	1180	1250	1250	1180	1060	1120	1180	1250	1250	560	750
	28	1180	1180	1250	1250	1250	1250	1250	1180	1250	1250	1180	1120	1180	1250	1250	1250	560	800
<b>2 800 000</b>	40	1060	1060	1180	1250	1250	1250	1180	1060	1250	1180	1060	1000	1000	1120	1250	1250	560	710
	28	1060	1120	1180	1250	1250	1250	1180	1120	1250	1180	1120	1060	1060	1120	1250	1250	560	750
<b>3 550 000</b>	40	950	1000	1060	1180	1250	1180	1120	1000	1250	1120	1000	950	950	1060	1180	1250	560	670
	28	1000	1000	1060	1180	1180	1180	1120	1000	1180	1120	1000	1000	1000	1060	1180	1180	560	670
	20	1000	1060	1060	1120	1180	1120	1120	1060	1180	1120	1060	1000	1000	1060	1120	1180	560	710
<b>max 1 250</b>																	<b>max 560</b>	<b>max 900</b>	

1) An axial load of up to 0,2 times the value in the table is permissible, simultaneously with the radial load. If exceeded consult us.  
 2) A radial load of up to 0,2 times the value in the table is permissible, simultaneously with the axial load. If exceeded consult us.  
 3) Values valid for taper roller bearings on low speed shaft (ch. 5).

# Radial $F_{r2}$ or axial loads $F_{a2}$ [daN] on low speed shaft end 3.12

size **125, 126**

$n_2 \cdot L_h$ min <sup>-1</sup> · h	$M_2$ daN m	$F_{r2}^{1)}$												$F_{a2}^{2)}$					
		0	45	90	135	180	225	270	315	0	45	90	135	180	225	270	315		
<b>90 000</b>	300	800	850	1320	1800	1800	1600	1500	950	1800	1600	900	630	710	1060	1800	1800	630	1120
	212 150	1060	1120	1400	1800	1800	1800	1600	1180	1800	1700	1180	950	1000	1320	1800	1800	800	1250
<b>112 000</b>	212	900	1000	1320	1800	1800	1800	1500	1060	1800	1500	1060	850	900	1180	1800	1800	750	1120
	150	1120	1180	1400	1800	1800	1800	1500	1250	1800	1600	1250	1060	160	1320	1700	1800	800	1180
<b>140 000</b>	212	800	900	1180	1700	1800	1800	1400	950	1800	1400	900	710	750	1060	1700	1800	630	1000
	150 106	1000	1060	1320	1700	1800	1800	1400	1120	1800	1500	1120	950	950	1250	1600	1800	800	1060
<b>180 000</b>	212	710	750	1060	1600	1600	1500	1250	850	1800	1320	800	600	630	950	1500	1800	530	850
	150 106 75	1000	1060	1250	1500	1600	1600	1320	1000	1700	1320	1000	800	850	1120	1500	1800	710	950
<b>224 000</b>	150	800	850	1060	1400	1700	1500	1180	900	1600	1250	900	710	750	1000	1400	1700	600	850
	106 75	1000	1060	1180	1320	1400	1500	1250	1000	1500	1250	1000	850	900	1060	1400	1600	710	900
<b>280 000</b>	150	710	750	1000	1320	1600	1500	1120	800	1500	1180	800	630	670	900	1320	1600	530	750
	106 75 53	850	900	1060	1320	1400	1400	1120	900	1400	1180	900	800	800	1000	1250	1500	630	800
<b>350 000</b>	150	630	670	900	1250	1500	1400	1000	710	1400	1060	710	560	560	800	1250	1500	425	670
	106 75 53	750	800	950	1180	1320	1250	1060	850	1320	1060	800	710	710	900	1180	1400	560	710
<b>450 000</b>	150	530	600	800	1180	1250	1180	950	630	1320	950	600	475	500	710	1120	1500	355	600
	106 75 53	670	710	900	1120	1250	1180	950	750	1250	1000	750	630	630	800	1120	1320	475	630
<b>560 000</b>	150	475	500	750	1120	1060	1000	850	560	1180	900	530	400	425	630	1060	1320	300	530
	106 75 53	600	630	800	1060	1180	1120	900	670	1180	900	670	560	560	750	1060	1250	400	600
<b>710 000</b>	106	530	560	750	1000	1120	1060	800	600	1120	850	600	475	500	670	950	1180	355	530
	75 53	630	630	750	950	1060	1000	850	670	1060	850	670	600	600	750	950	1060	425	560
<b>900 000</b>	106	450	500	670	900	1060	1000	750	530	1060	750	530	425	450	600	900	1120	300	475
	75 53	560	600	710	900	1000	950	750	630	1000	800	600	530	530	670	850	1000	375	500
<b>1 120 000</b>	106	400	450	600	850	950	900	670	475	1000	710	450	355	375	530	850	1060	250	425
	75 53 37,5	500	530	670	850	950	900	710	560	950	750	560	475	500	630	800	950	315	450
<b>1 400 000</b>	106	355	400	560	800	850	800	630	425	1000	750	600	530	560	670	800	900	375	450
	75 53 37,5	450	475	600	750	900	850	670	500	800	670	500	425	425	560	750	900	280	400
<b>1 800 000</b>	75	400	425	530	710	850	750	600	450	800	630	450	355	375	500	710	850	236	355
	53 37,5	450	475	560	710	750	750	630	500	750	630	500	450	450	560	670	800	280	375
<b>2 240 000</b>	75	355	375	500	670	800	710	560	400	750	560	400	315	335	450	670	800	200	315
	53 37,5	425	450	530	670	710	670	560	450	710	600	450	400	400	500	630	750	250	335
<b>2 800 000</b>	75	315	335	450	630	750	670	500	375	710	530	355	280	300	400	630	750	170	300
	53 37,5	375	400	475	600	670	630	530	425	670	530	400	355	375	450	600	710	212	300
<b>3 550 000</b>	75	265	300	400	600	630	600	475	315	670	475	300	236	250	355	560	750	140	265
	53 37,5	335	355	450	560	630	600	475	375	630	500	375	315	315	400	560	670	190	265
																		224	280
<b>max 1 800</b>																	<b>max 800</b>	<b>max 1 250</b>	

1) An axial load of up to 0,2 times the value in the table is permissible, simultaneously with the radial load. If exceeded consult us.  
 2) A radial load of up to 0,2 times the value in the table is permissible, simultaneously with the axial load. If exceeded consult us.



# Radial $F_{r2}$ or axial loads $F_{a2}$ [daN] on low speed shaft end 3.12

size **125 bis<sup>3)</sup>, 126 bis<sup>3)</sup>**

$n_2 \cdot L_m$  min <sup>-1</sup> · h	$M_2$  daN m	$F_{r2}^{1)}$														$F_{a2}^{2)}$				
		0	45	90	135	180	225	270	315	0	45	90	135	180	225	270	315	900	1400	
<b>≤224 000</b>	300	2000	2000	2000	2000	2000	2000	2000	2000	2000	2000	2000	2000	2000	2000	2000	2000	2000	900	1400
	212	2000	2000	2000	2000	2000	2000	2000	2000	2000	2000	2000	2000	2000	2000	2000	2000	2000	900	1400
<b>280 000</b>	150	2000	2000	2000	2000	2000	2000	2000	2000	2000	2000	2000	2000	2000	2000	2000	2000	2000	900	1400
	106	2000	2000	2000	2000	2000	2000	2000	2000	2000	2000	2000	2000	2000	2000	2000	2000	2000	900	1400
<b>355 000</b>	150	2000	2000	2000	2000	2000	2000	2000	2000	2000	2000	2000	2000	2000	2000	2000	2000	2000	900	1400
	106	2000	2000	2000	2000	2000	2000	2000	2000	2000	2000	2000	2000	2000	2000	2000	2000	2000	900	1400
<b>450 000</b>	150	2000	2000	2000	2000	2000	2000	2000	2000	2000	2000	2000	2000	2000	2000	2000	2000	2000	900	1400
	106	2000	2000	2000	2000	2000	2000	2000	2000	2000	2000	2000	2000	2000	2000	2000	2000	2000	900	1400
<b>560 000</b>	150	2000	2000	2000	2000	2000	2000	2000	2000	2000	2000	2000	2000	2000	2000	2000	2000	2000	900	1400
	106	2000	2000	2000	2000	2000	2000	2000	2000	2000	2000	2000	2000	2000	2000	2000	2000	2000	900	1400
<b>710 000</b>	106	2000	2000	2000	2000	2000	2000	2000	2000	2000	2000	2000	2000	2000	2000	2000	2000	2000	900	1400
	75	2000	2000	2000	2000	2000	2000	2000	2000	2000	2000	2000	2000	2000	2000	2000	2000	2000	900	1400
<b>900 000</b>	106	1900	2000	2000	2000	2000	2000	2000	2000	2000	2000	2000	1900	1900	2000	2000	2000	2000	900	1400
	75	2000	2000	2000	2000	2000	2000	2000	2000	2000	2000	2000	2000	2000	2000	2000	2000	2000	900	1400
<b>1 120 000</b>	106	1800	1900	2000	2000	2000	2000	2000	1900	2000	2000	1900	1800	1800	2000	2000	2000	2000	900	1320
	75	1900	1900	2000	2000	2000	2000	2000	2000	2000	2000	2000	1900	1900	2000	2000	2000	2000	900	1400
<b>1 400 000</b>	106	1700	1700	1900	2000	2000	2000	2000	1800	2000	2000	1800	1600	1700	1800	2000	2000	2000	900	1250
	75	1700	1800	1900	2000	2000	2000	2000	1800	2000	2000	1800	1700	1700	1900	2000	2000	2000	900	1320
<b>1 800 000</b>	106	1500	1600	1800	2000	2000	2000	1800	1600	2000	1800	1600	1500	1500	1700	2000	2000	2000	900	1180
	75	1600	1600	1800	1900	2000	2000	1800	1700	2000	1800	1700	1600	1600	1700	1900	2000	2000	900	1180
<b>2 240 000</b>	106	1600	1700	1800	1900	2000	1900	1800	1700	2000	1800	1700	1600	1600	1700	1800	1900	2000	900	1250
	75	1700	1700	1800	1900	1900	1900	1800	1700	1900	1800	1700	1700	1700	1800	1900	1900	1900	900	1250
<b>2 800 000</b>	106	1500	1500	1600	1800	1900	1800	1700	1500	1900	1700	1500	1400	1500	1600	1800	1900	1900	900	1060
	75	1500	1600	1700	1800	1800	1800	1700	1600	1800	1700	1600	1500	1500	1600	1800	1800	1800	900	1060
<b>3 550 000</b>	106	1320	1400	1500	1700	1800	1700	1600	1400	1800	1600	1400	1320	1320	1500	1700	1800	1800	850	1000
	75	1400	1400	1500	1600	1700	1700	1600	1500	1700	1600	1500	1400	1400	1500	1600	1700	1700	900	1000
	37,5	1500	1500	1500	1600	1700	1600	1600	1500	1700	1600	1500	1400	1500	1500	1600	1700	1700	900	1000
<b>max 2 000</b>																	<b>max 900</b>	<b>max 1 400</b>		

1) An axial load of up to 0,2 times the value in the table is permissible, simultaneously with the radial load. If exceeded consult us.  
 2) A radial load of up to 0,2 times the value in the table is permissible, simultaneously with the axial load. If exceeded consult us.  
 3) Values valid for taper roller bearings on low speed shaft (ch. 5).

# Radial $F_{r2}$ or axial loads $F_{a2}$ [daN] on low speed shaft end 3.12

size **160**

$n_2 \cdot L_h$	$M_2$	$F_{r2}^{1)}$														$F_{a2}^{2)}$			
min <sup>-1</sup> · h	daN m	0	45	90	135	180	225	270	315	0	45	90	135	180	225	270	315	710	1320
<b>90 000</b>	500	1000	1120	1700	2650	2500	2360	2120	1250	2650	2120	1120	800	900	1400	2650	2650	710	1320
	355	1400	1500	2000	2650	2650	2650	2240	1600	2650	2630	1600	1250	1320	1800	2650	2650	1000	1500
<b>112 000</b>	355	1250	1320	1800	2650	2650	2650	2000	1500	2650	2120	1400	1060	1120	1600	2500	2650	850	1320
	250	1500	1600	2000	2500	2650	2650	2120	1700	2650	2240	1600	1400	1500	1800	2500	2650	1120	1400
<b>140 000</b>	355	1060	1180	1600	2360	2650	2650	1900	1250	2650	1900	1180	950	1000	1400	2360	2650	750	1180
	250	1320	1400	1800	2360	2650	2500	2000	1500	2650	2000	1500	1250	1320	1700	2240	2650	950	1250
	180	1500	1600	1900	2240	2500	2360	2000	1700	2500	2000	1700	1500	1500	1800	2240	2500	1120	1320
<b>180 000</b>	355	900	1000	1500	2240	2360	2240	1700	1120	2650	1800	1000	750	850	1250	2120	2650	600	1060
	250	1180	1250	1600	2120	2500	2240	1800	1320	2360	1800	1320	1060	1120	1500	2120	2500	800	1120
	180	1400	1400	1700	2120	2240	2120	1800	1500	2240	1900	1500	1320	1320	1600	2000	2360	950	1180
	125	1500	1600	1800	2000	2120	2120	1800	1600	2120	1900	1600	1500	1500	1700	2000	2240	1060	1250
<b>224 000</b>	355	800	900	1320	2120	2000	1800	1600	950	2240	1600	900	630	710	1060	2000	2500	475	950
	250	1060	1120	1500	2000	2360	2120	1700	1250	2240	1700	1180	950	1000	1320	2000	2360	710	1000
	180	1250	1320	1600	1900	2120	2000	1700	1400	2120	1700	1320	1180	1180	1500	1900	2240	850	1060
	125	1400	1400	1600	1900	2000	1900	1700	1500	2000	1700	1500	1320	1400	1600	1900	2120	950	1120
<b>280 000</b>	250	950	1000	1320	1900	2240	2000	1500	1120	2120	1600	1060	850	900	1250	1800	2240	600	900
	180	1120	1180	1500	1800	2000	1900	1600	1250	2000	1600	1250	1060	1060	1320	1800	2120	750	950
	125	1250	1320	1500	1800	1900	1800	1600	1320	1900	1600	1320	1180	1250	1500	1700	1900	850	1000
	90	1320	1400	1500	1700	1800	1800	1600	1400	1800	1600	1400	1320	1320	1500	1700	1800	950	1060
<b>355 000</b>	250	800	900	1250	1800	2120	1900	1400	1000	2000	1400	900	710	750	1060	1700	2120	500	800
	180	1000	1120	1320	1700	1900	1800	1400	1120	1900	1500	1120	900	950	1250	1700	2000	630	850
	125	1120	1180	1400	1600	1800	1700	1500	1250	1800	1500	1250	1060	1120	1320	1600	1800	750	900
	90	1250	1250	1400	1600	1700	1600	1500	1320	1700	1500	1320	1180	1180	1400	1600	1700	850	950
<b>450 000</b>	250	710	800	1120	1600	1900	1700	1250	850	1900	1320	800	600	630	950	1600	2120	400	710
	180	900	950	1180	1600	1800	1700	1320	1000	1800	1400	1000	800	850	1120	1500	1900	560	800
	125	1000	1060	1250	1500	1700	1600	1320	1120	1700	1400	1120	1000	1000	1180	1500	1700	670	800
	90	1120	1120	1320	1500	1600	1500	1320	1180	1600	1400	1180	1060	1120	1250	1500	1600	710	850
<b>560 000</b>	250	600	670	1000	1500	1600	1500	1180	750	1700	1180	670	500	530	850	1500	1900	335	670
	180	800	850	1120	1500	1700	1600	1250	900	1700	1250	900	710	750	1000	1400	1800	475	710
	125	900	950	1180	1400	1600	1500	1250	1000	1600	1250	1000	900	900	1120	1400	1600	600	750
	90	1000	1060	1180	1400	1500	1400	1250	1060	1500	1250	1060	1000	1000	1180	1400	1500	670	750
<b>710 000</b>	250	500	560	900	1400	1250	1180	1060	670	1500	1120	560	400	450	710	1320	1600	265	600
	180	710	750	1000	1400	1600	1500	1120	800	1600	1180	800	630	650	900	1320	1700	400	630
	125	850	900	1060	1320	1500	1400	1120	950	1500	1180	900	800	800	1000	1320	1500	500	670
	90	900	950	1120	1250	1400	1320	1180	1000	1400	1180	1000	900	900	1060	1250	1400	560	670
<b>900 000</b>	180	600	670	900	1250	1500	1400	1000	710	1500	1060	670	530	560	800	1250	1600	335	560
	125	750	800	950	1250	1400	1320	1060	850	1400	1060	800	710	710	1000	1180	1400	425	600
	90	850	850	1000	1180	1320	1250	1060	900	1320	1120	900	800	850	950	1180	1320	500	600
<b>1 120 000</b>	180	530	600	800	1180	1400	1320	950	630	1400	950	600	450	500	710	1180	1500	280	500
	125	670	710	900	1180	1320	1250	1000	750	1320	1000	750	630	670	850	1120	1320	375	530
	90	750	800	950	1120	1250	1180	1000	850	1180	1000	850	710	750	900	1120	1250	450	560
	63	850	850	950	1120	1120	1120	1000	900	1120	1000	900	800	850	950	1060	1180	500	560
<b>1 400 000</b>	180	450	500	750	1120	1180	1120	850	560	1320	900	500	375	425	630	1060	1400	224	450
	125	600	630	800	1060	1250	1180	900	670	1250	950	670	560	600	750	1060	1250	335	475
	90	670	710	850	1060	1120	1120	900	750	1120	950	750	670	670	800	1000	1180	400	500
	63	750	800	900	1000	1060	1060	900	800	1060	950	800	750	750	850	1000	1120	450	530
<b>1 800 000</b>	125	530	560	750	1000	1180	1060	800	600	1120	850	600	475	500	670	1000	1180	265	425
	90	600	710	800	950	1060	1000	850	670	1060	850	670	600	600	750	950	1120	335	450
	63	670	710	800	950	1000	950	850	750	1000	850	750	670	670	800	950	1000	375	475
<b>2 240 000</b>	125	475	500	670	950	1120	1000	750	560	1060	800	530	425	450	600	900	1120	236	400
	90	560	600	710	900	1000	950	800	630	1000	800	600	530	530	670	900	1060	300	400
	63	630	670	750	900	950	900	800	670	950	800	670	600	630	710	850	950	335	425
<b>2 800 000</b>	125	400	450	600	900	1060	950	710	475	1000	710	450	355	375	530	850	1060	190	355
	90	500	530	670	850	950	900	710	560	950	750	560	475	475	630	850	1000	250	375
	63	560	600	710	800	900	850	750	630	900	750	600	530	560	670	800	900	300	375
<b>3 550 000</b>	125	355	400	560	800	950	850	630	425	950	670	400	300	335	475	800	1060	150	315
	90	450	475	600	800	900	850	670	500	900	670	500	400	425	560	800	950	212	335
	63	500	530	630	750	850	800	670	560	850	710	560	500	500	600	750	850	265	335

max **2 650**

max **1 180** | max **1900**

1) An axial load of up to 0,2 times the value in the table is permissible, simultaneously with the radial load. If exceeded consult us.  
 2) A radial load of up to 0,2 times the value in the table is permissible, simultaneously with the axial load. If exceeded consult us.

# Radial $F_{r2}$ or axial loads $F_{a2}$ [daN] on low speed shaft end **3.12**

size **161**

$n_2 \cdot L_n$ min <sup>-1</sup> · h	$M_2$ daN m	$F_{r2}^{1)}$														$F_{a2}^{2)}$			
		0	45	90	135	180	225	270	315	0	45	90	135	180	225	270	315		
≤180 000	500	3000	3000	3000	3000	3000	3000	3000	3000	3000	3000	3000	3000	3000	3000	3000	3000	1320	2120
	355	3000	3000	3000	3000	3000	3000	3000	3000	3000	3000	3000	3000	3000	3000	3000	3000	1320	2120
224 000	355	3000	3000	3000	3000	3000	3000	3000	3000	3000	3000	3000	3000	3000	3000	3000	3000	1320	2120
	250	3000	3000	3000	3000	3000	3000	3000	3000	3000	3000	3000	3000	3000	3000	3000	3000	1320	2120
280 000	355	3000	3000	3000	3000	3000	3000	3000	3000	3000	3000	3000	3000	3000	3000	3000	3000	1320	2120
	250	3000	3000	3000	3000	3000	3000	3000	3000	3000	3000	3000	3000	3000	3000	3000	3000	1320	2120
355 000	355	3000	3000	3000	3000	3000	3000	3000	3000	3000	3000	3000	3000	3000	3000	3000	3000	1320	2120
	250	3000	3000	3000	3000	3000	3000	3000	3000	3000	3000	3000	3000	3000	3000	3000	3000	1320	2120
450 000	355	3000	3000	3000	3000	3000	3000	3000	3000	3000	3000	3000	3000	3000	3000	3000	3000	1320	2120
	250	3000	3000	3000	3000	3000	3000	3000	3000	3000	3000	3000	3000	3000	3000	3000	3000	1320	2120
560 000	250	3000	3000	3000	3000	3000	3000	3000	3000	3000	3000	3000	3000	3000	3000	3000	3000	1320	2120
	180	3000	3000	3000	3000	3000	3000	3000	3000	3000	3000	3000	3000	3000	3000	3000	3000	1320	2120
	125	3000	3000	3000	3000	3000	3000	3000	3000	3000	3000	3000	3000	3000	3000	3000	3000	1320	2120
710 000	250	2650	2800	3000	3000	3000	3000	3000	2800	3000	3000	2800	2500	2650	3000	3000	3000	1320	2000
	180	2800	2800	3000	3000	3000	3000	3000	3000	3000	3000	2800	2800	2800	3000	3000	3000	1320	2000
	125	2800	3000	3000	3000	3000	3000	3000	3000	3000	3000	3000	2800	2800	3000	3000	3000	1320	2120
	90	3000	3000	3000	3000	3000	3000	3000	3000	3000	3000	3000	3000	3000	3000	3000	3000	1320	2120
900 000	250	2360	2500	2800	3000	3000	3000	3000	2500	3000	3000	2500	2360	2360	2800	3000	3000	1320	1800
	180	2500	2650	2800	3000	3000	3000	3000	2650	3000	3000	2650	2500	2500	2800	3000	3000	1320	1900
	125	2650	2800	3000	3000	3000	3000	3000	2800	3000	3000	2800	2650	2650	2800	3000	3000	1320	1900
	90	2800	2800	3000	3000	3000	3000	3000	2800	3000	3000	2800	2800	2800	2800	3000	3000	1320	1900
1 120 000	180	2360	2500	2650	3000	3000	3000	2800	2500	3000	2800	2500	2360	2360	2650	3000	3000	1320	1700
	125	2500	2500	2800	3000	3000	3000	2800	2650	3000	2800	2650	2500	2500	2650	3000	3000	1320	1800
	90	2500	2650	2800	2800	3000	3000	2800	2650	3000	2800	2650	2500	2500	2650	2800	3000	1320	1800
	63	2650	2650	2800	2800	3000	2800	2800	2650	2800	2800	2650	2650	2650	2800	2800	3000	1320	1800
1 400 000	180	2240	2240	2500	2800	3000	2800	2650	2360	3000	2650	2360	2120	2240	2500	2800	3000	1320	1600
	125	2360	2360	2500	2800	2800	2800	2650	2360	2800	2650	2360	2240	2360	2500	2800	3000	1320	1700
	90	2360	2500	2500	2650	2800	2800	2650	2500	2800	2650	2500	2360	2360	2500	2650	2800	1320	1700
	63	2500	2500	2500	2650	2650	2650	2650	2500	2800	2650	2500	2360	2500	2500	2650	2800	1320	1700
1 800 000	125	2240	2360	2500	2650	2800	2800	2500	2360	2800	2650	2360	2240	2240	2500	2650	2800	1320	1500
	90	2360	2360	2500	2650	2800	2650	2500	2360	2800	2650	2360	2240	2360	2500	2650	2800	1320	1600
	63	2360	2500	2500	2650	2650	2650	2500	2500	2650	2650	2500	2360	2360	2500	2650	2650	1320	1600
2 240 000	125	2120	2120	2360	2500	2650	2650	2360	2240	2650	2500	2120	2000	2120	2240	2500	2650	1250	1400
	90	2120	2240	2360	2500	2650	2500	2360	2240	2650	2360	2240	2120	2120	2360	2500	2650	1320	1500
	63	2240	2240	2360	2500	2500	2500	2360	2240	2500	2360	2240	2240	2240	2360	2500	2500	1320	1500
2 800 000	125	1900	2000	2120	2360	2500	2500	2240	2000	2500	2240	2000	1900	1900	2120	2360	2500	1180	1320
	90	2000	2120	2240	2360	2500	2360	2240	2120	2500	2360	2120	2000	2000	2120	2360	2500	1250	1400
	63	2120	2120	2240	2360	2360	2360	2240	2120	2360	2240	2120	2000	2120	2240	2360	2360	1320	1400
3 550 000	125	1800	1800	2000	2240	2360	2240	2120	1900	2360	2120	1900	1700	1800	2000	2240	2360	1060	1250
	90	1900	1900	2000	2240	2240	2240	2120	1900	2240	2120	1900	1800	1900	2000	2240	2360	1180	1250
	63	1900	2000	2000	2120	2240	2240	2120	2000	2240	2120	2000	1900	1900	2000	2120	2240	1180	1320
<b>max 3 000</b>																	<b>max 1 320</b>	<b>max 2 120</b>	

1) An axial load of up to 0,2 times the value in the table is permissible, simultaneously with the radial load. If exceeded consult us.  
 2) A radial load of up to 0,2 times the value in the table is permissible, simultaneously with the axial load. If exceeded consult us.

# Radial $F_{r2}$ or axial loads $F_{a2}$ [daN] on low speed shaft end 3.12

size **200**

$n_2 \cdot L_h$  min <sup>-1</sup> · h	$M_2$  daN m	$F_{r2}^{(1)}$												$F_{a2}^{(2)}$					
		0	45	90	135	180	225	270	315	0	45	90	135	180	225	270	315		
<b>140 000</b>	1000	4500	4500	4500	4500	4500	4500	4500	4500	4500	4500	4500	4500	4500	4500	4500	4500	2000	3150
	710	4500	4500	4500	4500	4500	4500	4500	4500	4500	4500	4500	4500	4500	4500	4500	4500	2000	3150
<b>180 000</b>	1000	4500	4500	4500	4500	4500	4500	4500	4500	4500	4500	4500	4500	4500	4500	4500	4500	2000	3150
	710	4500	4500	4500	4500	4500	4500	4500	4500	4500	4500	4500	4500	4500	4500	4500	4500	2000	3150
	500	4500	4500	4500	4500	4500	4500	4500	4500	4500	4500	4500	4500	4500	4500	4500	4500	2000	3150
<b>224 000</b>	710	4500	4500	4500	4500	4500	4500	4500	4500	4500	4500	4500	4500	4500	4500	4500	4500	2000	3150
	500	4500	4500	4500	4500	4500	4500	4500	4500	4500	4500	4500	4500	4500	4500	4500	4500	2000	3150
	355	4500	4500	4500	4500	4500	4500	4500	4500	4500	4500	4500	4500	4500	4500	4500	4500	2000	3150
<b>280 000</b>	710	4500	4500	4500	4500	4500	4500	4500	4500	4500	4500	4500	4250	4500	4500	4500	4500	2000	3150
	500	4500	4500	4500	4500	4500	4500	4500	4500	4500	4500	4500	4500	4500	4500	4500	4500	2000	3150
	355	4500	4500	4500	4500	4500	4500	4500	4500	4500	4500	4500	4500	4500	4500	4500	4500	2000	3150
	250	4500	4500	4500	4500	4500	4500	4500	4500	4500	4500	4500	4500	4500	4500	4500	4500	2000	3150
	180	4500	4500	4500	4500	4500	4500	4500	4500	4500	4500	4500	4500	4500	4500	4500	4500	2000	3150
<b>355 000</b>	500	4500	4500	4500	4500	4500	4500	4500	4500	4500	4500	4500	4250	4500	4500	4500	4500	2000	3150
	355	4500	4500	4500	4500	4500	4500	4500	4500	4500	4500	4500	4500	4500	4500	4500	4500	2000	3150
	250	4500	4500	4500	4500	4500	4500	4500	4500	4500	4500	4500	4500	4500	4500	4500	4500	2000	3150
	180	4500	4500	4500	4500	4500	4500	4500	4500	4500	4500	4500	4500	4500	4500	4500	4500	2000	3150
<b>450 000</b>	500	4000	4250	4500	4500	4500	4500	4500	4500	4500	4500	4250	4000	4000	4500	4500	4500	2000	3150
	355	4250	4500	4500	4500	4500	4500	4500	4500	4500	4500	4500	4250	4250	4500	4500	4500	2000	3150
	250	4500	4500	4500	4500	4500	4500	4500	4500	4500	4500	4500	4500	4500	4500	4500	4500	2000	3150
	180	4500	4500	4500	4500	4500	4500	4500	4500	4500	4500	4500	4500	4500	4500	4500	4500	2000	3150
<b>560 000</b>	500	3750	4000	4500	4500	4500	4500	4500	4000	4500	4500	4000	3550	3750	4250	4500	4500	2000	3000
	355	4000	4250	4500	4500	4500	4500	4500	4250	4500	4500	4250	4000	4000	4500	4500	4500	2000	3000
	250	4250	4250	4500	4500	4500	4500	4500	4250	4500	4500	4250	4000	4250	4500	4500	4500	2000	3150
	180	4250	4250	4500	4500	4500	4500	4500	4500	4500	4500	4250	4250	4250	4500	4500	4500	2000	3150
	125	4500	4500	4500	4500	4500	4500	4500	4500	4500	4500	4500	4250	4500	4500	4500	4500	2000	3150
<b>710 000</b>	500	3350	3550	4250	4500	4500	4500	4250	3750	4500	4250	3550	3350	3350	4000	4500	4500	2000	2650
	355	4000	3750	4250	4500	4500	4500	4250	3750	4500	4250	3750	3550	3750	4000	4500	4500	2000	2800
	250	4000	4000	4250	4500	4500	4500	4250	4000	4500	4250	4000	3750	3750	4250	4500	4500	2000	3000
	180	4000	4000	4250	4500	4500	4500	4250	4000	4500	4250	4000	4000	4000	4250	4500	4500	2000	3000
	125	4000	4250	4250	4500	4500	4500	4250	4250	4500	4250	4250	4000	4000	4250	4500	4500	2000	3000
<b>900 000</b>	355	3350	3550	4000	4250	4500	4500	4000	3550	4500	4000	3550	3350	3350	3750	4250	4500	2000	2650
	250	3550	3750	4000	4250	4500	4250	4000	3750	4500	4000	3750	3550	3550	4000	4250	4500	2000	2650
	180	3750	3750	4000	4250	4250	4250	4000	3750	4250	4000	3750	3550	3750	4000	4250	4250	2000	2800
	125	3750	3750	4000	4250	4250	4250	4000	3750	4250	4000	3750	3750	3750	4000	4250	4250	2000	2800
<b>1 120 000</b>	355	3150	3350	3750	4000	4250	4250	3750	3350	4250	3750	3350	3000	3150	3550	4000	4500	2000	2500
	250	3350	3350	3750	4000	4250	4000	3750	3350	4250	3750	3350	3150	3350	3550	4000	4250	2000	2500
	180	3350	3550	3750	4000	4000	4000	3750	3550	4000	3750	3550	3350	3350	3550	4000	4000	2000	2500
	125	3550	3550	3750	4000	4000	4000	3750	3550	4000	3750	3550	3550	3550	3750	4000	4000	2000	2650
<b>1 400 000</b>	355	3000	3000	3350	4000	4000	4000	3550	3000	4000	3550	3000	2800	2800	3350	3750	4250	1900	2240
	250	3000	3150	3550	3750	4000	3750	3550	3150	4000	3550	3150	3000	3000	3350	3750	4000	2000	2360
	180	3150	3350	3550	3750	3750	3750	3550	3350	3750	3550	3350	3150	3150	3350	3750	3750	2000	2360
	125	3350	3350	3550	3550	3750	3550	3550	3350	3750	3550	3350	3150	3350	3350	3550	3750	2000	2360
	<b>1 800 000</b>	355	2650	2800	3150	3550	3750	3550	3150	2800	3750	3350	2800	2500	2650	3000	3550	4000	1700
250		2800	3000	3150	3550	3550	3550	3150	3000	3550	3350	3000	2800	2800	3150	3550	3750	1900	2120
180		3000	3000	3150	3350	3550	3350	3150	3000	3550	3350	3000	2800	3000	3150	3350	3550	2000	2240
125		3000	3000	3150	3350	3350	3350	3150	3150	3350	3350	3000	3000	3000	3150	3350	3550	2000	2240
<b>2 240 000</b>	250	2650	2650	3000	3350	3350	3350	3000	2800	3350	3000	2650	2500	2650	3000	3350	3550	1800	2000
	180	2800	2800	3000	3150	3350	3150	3000	2800	3350	3000	2800	2650	2650	3000	3150	3350	1900	2000
	125	2800	2800	3000	3150	3150	3150	3000	2800	3150	3000	2800	2800	2800	3000	3150	3350	2000	2120
<b>2 800 000</b>	250	2360	2500	2800	3150	3350	3150	2800	2500	3150	2800	2500	2360	2360	2650	3150	3350	1600	1900
	180	2500	2650	2800	3000	3150	3000	2800	2650	3150	2800	2650	2500	2500	2800	3000	3150	1700	1900
	125	2650	2650	2800	3000	3000	3000	2800	2650	3000	2800	2650	2650	2650	2800	3000	3000	1800	1900
<b>3 550 000</b>	250	2240	2360	2650	3000	3000	3000	2650	2360	3000	2650	2360	2120	2240	2360	3000	3150	1500	1700
	180	2360	2360	2650	2800	3000	2800	2650	2360	3000	2650	2360	2240	2360	2500	2800	3000	1600	1800
	125	2360	2500	2650	2800	2800	2800	2650	2500	2800	2650	2500	2360	2360	2650	2800	3000	1700	1800

max **4 500**

max **2 000** | max **3 150**

1) An axial load of up to 0,2 times the value in the table is permissible, simultaneously with the radial load. If exceeded consult us.  
 2) A radial load of up to 0,2 times the value in the table is permissible, simultaneously with the axial load. If exceeded consult us.



## Worm gear pair

Number of teeth – wormwheel  $z_2$  and worm  $z_1$ , axial module  $m_x$ , reference lead angle  $\gamma_m$ , static efficiency  $\eta_s$  and worm gear pair moment of inertia  $J_1$  for gear reducers and gearmotors **R V**, **R IV**, **MR V**, **MR IV**, **MR 2IV**.

In the case of **R IV**, **MR IV** and **MR 2IV** gear reducers and gearmotors, the moment of inertia on the high speed shaft (disregarding motor) is that of the worm divided by the cylindrical gear pair total ratio squared.

$i$		Gear reducer size									
		32	40	50	63, 64	80, 81	100	125, 126	160, 161	200	250
7	$z_2/z_1$	21/3	21/3	21/3	28/4	28/4	—	—	—	—	—
	$m_x$	2,2	2,8	3,4	3,5	4,5	—	—	—	—	—
	$\gamma_m$	22° 29'	22° 29'	22° 35'	28° 35'	28° 30'	—	—	—	—	—
	$\eta_s$	0,71	0,71	0,71	0,74	0,74	—	—	—	—	—
10	$z_2/z_1$	20/2	20/2	20/2	30/3	30/3	30/3	30/3	30/3	—	—
	$m_x$	2,3	2,8	3,5	3,3	4,2	5,3	6,6	8,6	—	—
	$\gamma_m$	15° 10'	15° 10'	15° 7'	19° 52'	20° 28'	21° 20'	21° 53'	23° 1'	—	—
	$\eta_s$	0,65	0,65	0,65	0,69	0,7	0,7	0,7	0,72	—	—
13	$z_2/z_1$	26/2	26/2	26/2	26/2	26/2	26/2	39/3	39/3	39/3	—
	$m_x$	1,8	2,3	2,9	3,7	4,7	5,9	5,2	6,8	8,5	—
	$\gamma_m$	13° 28'	13° 14'	13° 36'	14° 23'	14° 48'	15° 24'	18° 48'	19° 52'	20° 38'	—
	$\eta_s$	0,62	0,62	0,63	0,64	0,64	0,65	0,68	0,69	0,7	—
16	$z_2/z_1$	32/2	32/2	32/2	32/2	32/2	32/2	32/2	32/2	48/3	48/3
	$m_x$	1,5	1,9	2,4	3,1	3,9	4,9	6,2	8	7,1	9
	$\gamma_m$	11° 52'	11° 53'	12° 4'	12° 47'	13° 14'	13° 47'	14° 7'	14° 52'	19° 4'	20° 21'
	$\eta_s$	0,6	0,6	0,6	0,61	0,62	0,63	0,63	0,64	0,68	0,69
20	$z_2/z_1$	20/1	20/1	20/1	40/2	40/2	40/2	40/2	40/2	40/2	40/2
	$m_x$	2,3	2,8	3,5	2,5	3,2	4,1	5,1	6,6	8,3	10,4
	$\gamma_m$	7° 41'	7° 40'	7° 46'	11° 46'	12° 1'	12° 29'	12° 24'	13° 6'	13° 36'	14° 3'
	$\eta_s$	0,5	0,5	0,5	0,6	0,6	0,61	0,61	0,62	0,63	0,63
25	$z_2/z_1$	25/1	25/1	25/1	25/1	25/1	25/1	50/2	50/2	50/2	50/2
	$m_x$	1,9	2,4	3	3,8	4,8	6,1	4,2	5,4	6,8	8,6
	$\gamma_m$	6° 55'	6° 52'	6° 58'	7° 21'	7° 34'	7° 53'	11° 33'	11° 49'	12° 28'	13° 18'
	$\eta_s$	0,48	0,48	0,48	0,5	0,5	0,51	0,59	0,6	0,61	0,62
32	$z_2/z_1$	32/1	32/1	32/1	32/1	32/1	32/1	32/1	32/1	32/1	64/2
	$m_x$	1,5	1,9	2,4	3,1	3,9	4,9	6,2	8	10,1	6,8
	$\gamma_m$	6°	6°	6° 3'	6° 25'	6° 38'	6° 55'	7° 5'	7° 27'	7° 43'	11° 22'
	$\eta_s$	0,45	0,45	0,45	0,46	0,47	0,48	0,49	0,5	0,51	0,59
40	$z_2/z_1$	40/1	40/1	40/1	40/1	40/1	40/1	40/1	40/1	40/1	40/1
	$m_x$	1,3	1,6	2	2,5	3,2	4,1	5,1	6,6	8,3	10,4
	$\gamma_m$	5° 12'	5° 10'	5° 16'	5° 54'	6° 2'	6° 16'	6° 13'	6° 34'	6° 50'	7° 3'
	$\eta_s$	0,42	0,42	0,42	0,44	0,45	0,46	0,46	0,47	0,48	0,49
50	$z_2/z_1$	50/1	50/1	50/1	50/1	50/1	50/1	50/1	50/1	50/1	50/1
	$m_x$	1	1,3	1,6	2,1	2,7	3,3	4,2	5,4	6,8	8,6
	$\gamma_m$	4° 29'	4° 25'	4° 32'	5° 7'	5° 15'	5° 27'	5° 48'	5° 56'	6° 15'	6° 41'
	$\eta_s$	0,38	0,38	0,38	0,41	0,42	0,43	0,44	0,45	0,46	0,47
63	$z_2/z_1$	—	63/1	63/1	63/1	63/1	63/1	63/1	63/1	63/1	63/1
	$m_x$	—	1	1,3	1,7	2,1	2,7	3,4	4,4	5,5	6,9
	$\gamma_m$	—	3° 43'	3° 50'	4° 21'	4° 27'	4° 39'	4° 57'	5° 5'	5° 22'	5° 46'
	$\eta_s$	—	0,34	0,35	0,38	0,38	0,39	0,4	0,41	0,42	0,44
Moment of inertia (of mass) $J_1$ [kg m <sup>2</sup> ] on the worm $\approx$		—	—	—	—	—	0,0014	0,0037	0,0078	0,0192	0,0376

## Low speed shaft angular backlash

**A rough guide** for low speed shaft angular backlash is given in the table (the worm being held stationary). Values vary according to design and temperature.

Gear reducers with **controlled** or **reduced backlash** can be supplied on request (see ch. 5), subject to longer delivery times and price addition; choose a **higher** service factor.

Gear reducer size	Angular backlash [rad] <sup>1</sup>	
	min	max
<b>32</b>	0,0030	0,0118
<b>40</b>	0,0025	0,0100
<b>50</b>	0,0020	0,0080
<b>63, 64</b>	0,0018	0,0071
<b>80, 81</b>	0,0016	0,0063
<b>100</b>	0,0013	0,0050
<b>125, 126</b>	0,0011	0,0045
<b>160, 161</b>	0,0010	0,0040
<b>200</b>	0,0008	0,0032
<b>250</b>	0,0007	0,0028

<sup>1</sup> At a distance of 1 m from the low speed shaft centre, angular backlash in mm is obtained multiplying the table value by 1 000 (1 rad = 3438').

## Gear ratio of input helical gear stage (garmotors MR IV, MR 2IV)

The partial transmission ratio of input helical gear stage is given in the table; this ratio has to be used when calculating the input speed of the intermediate worm shaft.

$i_N$	MR IV gearmotor size																															
	Motor main coupling dimensions $\varnothing d \ \varnothing P$																															
	32		40, 50		63 ... 100			125, 126			160 ... 200			250																		
	11x140	11x140	14x160	19x200	14x160 (19x200) <sup>1)</sup>	19x200 (24x200) <sup>1)</sup>	24x200 (28x250) <sup>1)</sup>	24x200	28x250	38x300	28x250	38x300	42x350 48x350	38x300	42x350 48x350	55x400 60x450																
$i$	2)	$i$	2)	$i$	2)	$i$	2)	$i$	2)	$i$	2)	$i$	2)	$i$	2)	$i$	2)															
31,5	-	-	-	-	32,5	2,03	-	-	-	-	-	-	-	-	-	32	2															
40	41,5	2,59	-	-	40,6	2,54	-	-	40,6	2,54	40,6	2,03	-	-	40,9	2,56	40	2														
50	51,8	2,59	56	3,5	50,7	2,54	50,8	2,03	50,9	3,18	50,8	2,54	50	2	-	-	51,1	2,56	50	2												
63	64,8	2,59	70	3,5	63,4	2,54	65	2,03	63,6	3,18	63,5	2,54	64	2	-	-	63,9	2,56	64	2												
80	82,9	2,59	87,5	3,5	81,1	2,54	-	-	79,5	3,18	81,2	2,54	80	2	78,1	3,13	81,1	2,54	81,2	2,03	79,3	3,17	81,8	2,56	80	2						
100	104	2,59	112	3,5	101	2,54	-	-	102	3,18	102	2,54	100	2	100	3,13	101	2,54	-	-	102	3,17	102	2,56	102	2,56	102	2,56	102	2,56		
125	-	-	140	3,5	127	2,54	-	-	122	3,8	127	2,54	126	2	125	3,13	125	3,13	-	-	127	3,17	128	2,56	128	2,56	127	3,17	127 <sup>3)</sup>	3,17 <sup>3)</sup>	-	-
160	-	-	175	3,5	-	-	-	-	152	3,8	160	2,54	-	-	154	3,86	156	3,13	-	-	160	4	161	2,56	-	-	152	3,8	159	3,17	-	-
200	-	-	221	3,5	-	-	-	-	190	3,8	-	-	-	-	193	3,86	197	3,13	-	-	200	4	-	-	-	-	190	3,8	200	3,17	-	-
250	-	-	-	-	-	-	-	-	239	3,8	-	-	-	-	243	3,86	-	-	-	-	252	4	-	-	-	-	239	3,8	-	-	-	-

$i_N$	MR 2IV gearmotor size															
	Motor main coupling dimensions $\varnothing d \ \varnothing P$															
	40, 50		63 ... 81			100		125, 126								
	11x140	14x160	14x160	19x200	19x200	24x200	24x200	28x250								
$i$	2)	$i$	2)	$i$	2)	$i$	2)	$i$	2)	$i$	2)					
80	-	-	82,4	5,15	-	-	-	-	81,2	5,08	-	-	82,3	5,15		
100	114	7,11	103	5,15	-	-	102	5,08	-	-	102	5,08	-	-	103	5,15
125	142	7,11	129	5,15	-	-	127	5,08	-	-	127	5,08	-	-	129	5,15
160	178	7,11	158	7,91	159	6,36	162	5,08	159	6,36	162	5,08	159	6,34	165	5,15
200	218	10,9	198	7,91	204	6,36	202	8,08	204	6,36	202	8,08	203	6,34	206	5,15
250	273	10,9	-	-	253	10,1	258	8,08	253	10,1	258	8,08	254	6,34	253	7,91
315	349	10,9	-	-	302	12,1	323	8,08	302	12,1	-	-	312	9,75	-	-
400	437	10,9	-	-	387	12,1	-	-	387	12,1	-	-	385	12	-	-
500	-	-	-	-	484	12,1	-	-	484	12,1	-	-	481	12	-	-
630	-	-	-	-	605	12,1	-	-	605	12,1	-	-	602	12	-	-

1) Motor coupling dimensions valid for gearmotor size 100.  
 2) Partial transmission ratio of input helical gear stage.  
 3) With motor size 180 values are 128 and 2,56 respectively.

## Efficiency $\eta$

Efficiency  $\eta$  is derived from the  $P_{N2} / P_{N1}$  ratio in the case of gear reducers (ch. 3.5) and  $P_2 / P_1$  in the case of gearmotors (ch. 9). The values obtained will be valid assuming normal working conditions, worm operating as driving member, proper lubrication, adequate running-in (ch. 4), and a load near to the nominal value.

During the **initial working period** (about 50 hours) and generally at every cold start, efficiency will be lower (by about 12% for worms with  $z_1 = 1$ ; 6% for worms with  $z_1 = 2$  and 3% for worms with  $z_1 = 3$ ).

«**Static**» efficiency  $\eta_s$  on starting (see table in the preceding section) is much lower than  $\eta$  («starting friction») must be overcome at speed 0; as speed picks up gradually, efficiency will rise correspondingly until the catalogue value is reached.

**Inverse efficiency**  $\eta_{inv}$  – produced by the wormwheel as driver – is always less than  $\eta$ . It can be calculated approximately as follows:

$$\eta_{inv} \approx 2 - 1 / \eta; \quad \text{likewise:} \quad \eta_s \approx 2 - 1 / \eta_s$$

## Irreversibility

A worm gear reducer or gearmotor is **dynamically irreversible** (that is, it ceases to turn the instant the wormshaft receives no further stimulus that would keep the worm itself in rotation e.g. motor torque, inertia from the worm and related fan, motor flywheels, couplings, etc.) when  $\eta < 0,5$  as  $\eta_{inv}$  then drops below 0.

This state becomes necessary wherever there is a **need for stopping and holding** the load, even without the aid of a brake. Where continuous vibration occurs, dynamic irreversibility may not be obtainable.

A gear reducer or gearmotor is **statically irreversible** (that is, rotation cannot be imparted by way of the low speed shaft) when  $\eta_s < 0,5$ . This is a state **necessary to keep the load at standstill**; taking into account, however, that efficiency can increase with time spent in operation, it would be advisable to assume  $\eta_s \leq 0,4$  ( $\gamma_m < 5^\circ$ ).

Where continuous vibration occurs, static irreversibility may not be obtainable.

A gear reducer or gearmotor has **low static reversibility** (i.e. rotation may be imparted by way of the low speed shaft with high torque and/or vibration) when  $0,5 < \eta_s \leq 0,6$  ( $7^\circ 30' < \gamma_m \leq 12^\circ$ ).

A gear reducer or gearmotor has **complete static reversibility** (i.e. rotation may be imparted by way of the low speed shaft) when  $\eta_s > 0,6$  ( $\gamma_m > 12^\circ$ ).

This state is advisable where there is a **need for easy start-up of the gear reducer by way of the low speed shaft**.

## Overloads

Since worm gear pairs are often subject to high static and dynamic overloads by dint of the fact that they are especially suited to bear them, the need arises – more so than with other gear pairs – for verifying that such overloads will always remain lower than  $M_{2max}$  (ch. 3.5).

Overloads are normally generated when one has:

- starting on full load (especially for high inertias and low transmission ratios), braking, shocks;
- irreversible gear reducers, or gear reducers with low reversibility in which the wormwheel becomes driver due to driven machine inertia;
- applied power higher than that required; other static or dynamic causes.

The following general observations on overloads are accompanied by some formulae for carrying out evaluations in certain typical instances.

Where no evaluation is possible, install safety devices which will keep values within  $M_{2max}$ .

## Starting torque

When starting on full load (especially for high inertias and low transmission ratios) verify that  $M_{2max}$  is equal to or greater than starting torque, by using the following formula:

$$M_2 \text{ start} = \left( \frac{M_{\text{start}}}{M_N} \cdot M_2 \text{ available} - M_2 \text{ required} \right) \frac{J}{J + J_0 \cdot \eta} + M_2 \text{ required}$$

where:

$M_2$  required is torque absorbed by the machine through work and friction;

$M_2$  available is output torque derived from the motor's nominal power rating;

$J_0$  is the moment of inertia (of mass) of the motor;

$J$  is the external moment of inertia (of mass) in kg m<sup>2</sup> (gear reducers, couplings, driven machine) referred to the motor shaft;

for other symbols see ch. 2b.

NOTE: When seeking to verify that starting torque is sufficiently high for starting, take into account efficiency  $\eta$  when evaluating  $M_2$  available, and starting friction, if any, in evaluating  $M_2$  required.

## Stopping machines with high kinetic energy (high moments of inertia combined with high speeds) with or without braking (braking applied to wormshaft, or use of brake motor)

Select a gear reducer with static reversibility ( $\eta_s > 0,5$ ); if using a brake motor, verify braking stress with the following formula:

$$\left( \frac{Mf}{\eta_{s \text{ inv}}} \cdot i + M_2 \text{ required} \right) \frac{J}{J + J_0 / \eta_{s \text{ inv}}} - M_2 \text{ required} \leq M_{2 \text{ max}}$$

where:

$Mf$  is the braking torque setting (see table in ch. 2b).

$\eta_{s \text{ inv}}$  is static inverse efficiency (see previous heading);

for other symbols see above and ch.1.

Where selection of a statically reversible gear reducer is not possible (i.e.  $\eta_s \leq 0,5$ ) slowing-down should be sufficiently gradual (avoiding application of excessive stress to the unit itself) as to ensure that:

$$\frac{J_2 \cdot \alpha_2}{10} - M_2 \leq M_{2 \text{ max}}$$

where:

$J_2$  [kg m<sup>2</sup>] is the moment of inertia (of mass) of the driven machine referred to the gear reducer's low speed shaft;

$M_2$  [daN m] is torque absorbed by the machine through work and friction;

$\alpha_2$  [rad/s<sup>2</sup>] is the low speed shaft's angular deceleration; this may be reduced by flywheel fitted to the wormshaft, electric deceleration ramps, lowering of braking torque when braking systems are in use, etc.

$\alpha_2$  may be arrived at theoretically (within broadly safe limits) or experimentally (by testing against stopping time and distance etc.).

If a brake motor is in use, the following formula may be used for a safe evaluation of  $\alpha_2$ :

$$\alpha_2 = \frac{10 \cdot Mf}{J_0 \cdot i}$$

in which the motor is presumed without load and subject to its braking torque setting  $Mf$  [daN m] (see table in ch. 2b).



## Operation with brake motor

**Stating time  $t_a$  and revolutions of motor  $\varphi_{a_1}$**

$$t_a = \frac{(J_0 + J/\eta) \cdot n_1}{95,5 \left( M_{start} - \frac{M_2 \text{ required}}{i \cdot \eta} \right)} \text{ [s];} \quad \varphi_{a_1} = \frac{t_a \cdot n_1}{19,1} \text{ [rad]}$$

**Braking time  $t_f$  and revolutions of motor  $\varphi_{f_1}$**

$$t_f = \frac{(J_0 + J/\eta_{inv}) \cdot n_1}{95,5 \left( M_{f+} - \frac{M_2 \text{ required} \cdot \eta_{inv}}{i} \right)} \text{ [s];} \quad \varphi_{f_1} = \frac{t_f \cdot n_1}{19,1} \text{ [rad]}$$

where:

$M_{start}$  [daN m] is motor starting torque  $\left( \frac{955 \cdot P_n}{n_1} \cdot \frac{M_{start}}{M_N} \right)$  (see ch. 2b);

$M_f$  [daN m] is the braking torque setting of the motor (see ch. 2b);

for other symbols see above and ch. 1.

With the gear reducer run in and operating at normal running temperature — assuming a regular air-gap and ambient humidity and utilizing suitable electrical equipment — repetition of the braking action, as affected by variation in temperature of the brake and by the state of wear of friction surface, is approx  $\pm 0,1 \cdot \varphi_{f_1}$ .

During warm-up (1 ÷ 3 h, small through to large sizes), braking times and distances tend to increase to the point of stabilizing at or around values corresponding to rated catalogue efficiency.

## Duration of friction surface

As a rough guide, the number of applications permissible between successive adjustments of the air-gap is given by the following formula:

$$\frac{W \cdot 10^5}{M_f \cdot \varphi_{f_1}}$$

where:

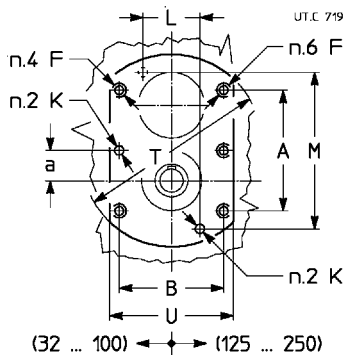
$W$  [MJ] is the work of friction between successive adjustments of the air-gap as indicated in the table. For other symbols see above.

The air-gap should measure between 0,25 minimum and 0,7 maximum; as a rough guide, 5 adjustments can be made.

Grandezza motore Motor size	W MJ
63	10,6
71	14
80	18
90	24
100	24
112	45
132	67
160, 180M	90
180L, 200	125

## Gear reducers input face

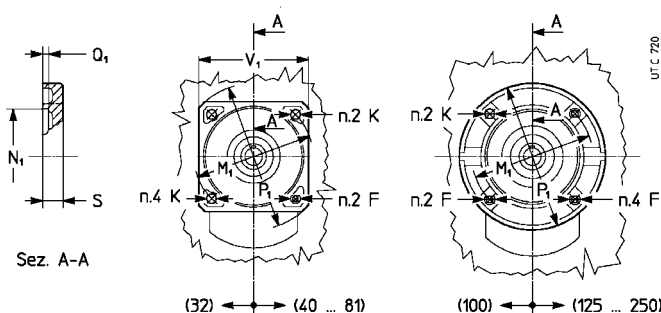
The **R V** gear reducer input face has a machined surface with tapped holes for fitting motor mounting etc.



Grandezza riduttore Gear reducer size	a	A	B	F	K Ø H8	L	M	T Ø	U
32	16	72	54	M 5	5	—	—	103	66
40, 50	20	81,5	66,5	M 5	5	—	—	119	80
63 ... 81	25	106	80	M 6	6	—	—	149	96
100	31,3	125	108	M 8	8	—	—	187	129
125, 126	40	166	136	M 8	8	78	216	252	157
160 ... 200	50	214	168	M 10	10	98	268	312	194
250	62,5	274	210	M 12	12	128	332	387	241

1) Working length of thread 2 · F.  
2) Working length of hole 1,6 · K.

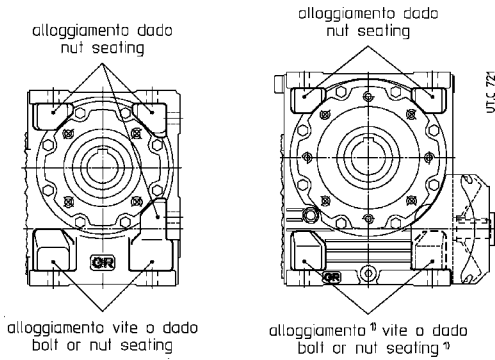
The **R IV** gear reducer input face has a machined flange with holes for fitting motor mountings etc.



Grandezza riduttore Gear reducer size	F	K Ø	M <sub>1</sub> Ø	N <sub>1</sub> Ø H7	P Ø	V <sub>1</sub> □	Q <sub>1</sub>	S
32	—	9,5	115	95	140	105	4	10
40, 50	M 8	9,5	115	95	140	105	4	11
63 ... 81	M 8	9,5	130	110	160	120	4,5	12
100	M 10	11,5	165	130	200	—	4,5	14
125, 126	M 10	—	165	130	200	—	4,5	16
160 ... 200	M 12	—	215	180	250	—	5	18
250	M 12	—	265	230	300	—	5	20

1) Working length of thread 1,25 · F.

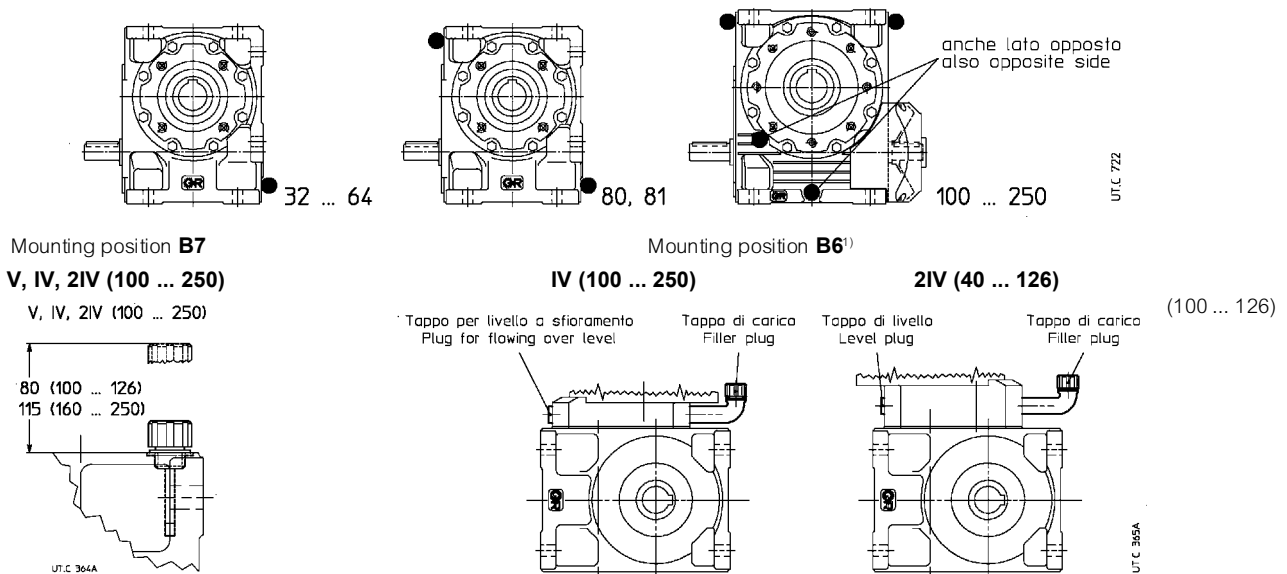
## Fixing bolt dimensions for gear reducer feet



1) When tightening bolts at the fan side (sizes 100 ... 250) the fan cowl (which must enclose the fan assembly in order to enhance air-flow) needs to be removed for the purpose. When installing, ensure the cowl clears any surrounding walls by at least half the gear reducer's centre distance.

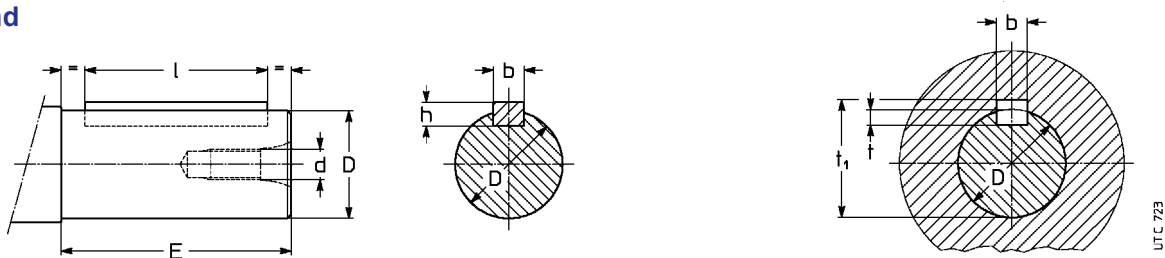
Grandezza riduttore Gear reducer size	Vite Bolt UNI 5737-88 (l max)
32	M 6 × 25
40	M 8 × 35
50	M 8 × 40
63, 64	M 10 × 50
80, 81	M 12 × 60
100	M 14 × 55
125, 126	M 16 × 65
160, 161	M 20 × 80
200	M 24 × 90
250	M 30 × 120

## Plug position



1) For high input speed duty an expansion tank is envisaged.

## Shaft end



### Shaft end

Shaft end				Parallel key		Keyway		
D <sup>1)</sup> Ø		E <sup>2)</sup>	d Ø	b × h × l <sup>2)</sup>		b	t	t <sub>1</sub>
11	j6	23	(20)	M 5	4 × 4 × 18 (12)	4	2,5	12,7
14	j6	30	(25)	M 6	5 × 5 × 25 (16)	5	3	16,2
16	j6	30		M 6	5 × 5 × 25	5	3	18,2
19	j6	40	(30)	M 6	6 × 6 × 36 (25)	6	3,5	21,7
24	j6	50	(36)	M 8	8 × 7 × 45 (25)	8	4	27,2
28	j6	60	(42)	M 8	8 × 7 × 45 (36)	8	4	31,2
32	k6	80	(58)	M 10	10 × 8 × 70 (50)	10	5	35,3
38	k6	80	(58)	M 10	10 × 8 × 70 (50)	10	5	41,3
40	h7	58		M 10	12 × 8 × 50	12	5	43,3
48	k6	110	(82)	M 12	14 × 9 × 90 (70)	14	5,5	51,8
55	m6	110	(82)	M 12	16 × 10 × 90 (70)	16	6	59,3
60	m6	105		M 16	18 × 11 × 90	18	7	64,4
70	j6	105		M 16	20 × 12 × 90	20	7,5	74,9
75	j6	105		M 16	20 × 12 × 90	20	7,5	79,9
90	j6	130		M 20	25 × 14 × 110	25	9	95,4
110	j6	165		M 24	28 × 16 × 140	28	10	116,4

### Hollow low speed shaft

Hole	Parallel key	Keyway		
D Ø H7	b × h × l*	b	t	t <sub>1</sub>
19	6 × 6 × 36	6	3,5	21,7
24	8 × 7 × 45	8	4	27,2
28	8 × 7 × 63	8	4	31,2
32	10 × 8 × 70	10	5	35,3
38	10 × 8 × 90	10	5	41,3
40	12 × 8 × 90	12	5	43,3
48	14 × 9 × 110	14	5,5	51,8
60	18 × 11 × 140	18	7	64,4
70	20 × 12 × 180	20	7,5	74,9
75	20 × 12 × 180	20	7,5	79,9
90	25 × 14 × 200	25	9	95,4
110	28 × 16 × 250	28	10	116,4

\* Recommended length.

1) Tolerance valid only for high speed shaft end. Diameter D tolerance for low speed shaft end (ch. 5) is h7 for D ≤ 60, j6 for D ≥ 70.  
2) Values in brackets are for short shaft end.

## Shaft end of driven machine

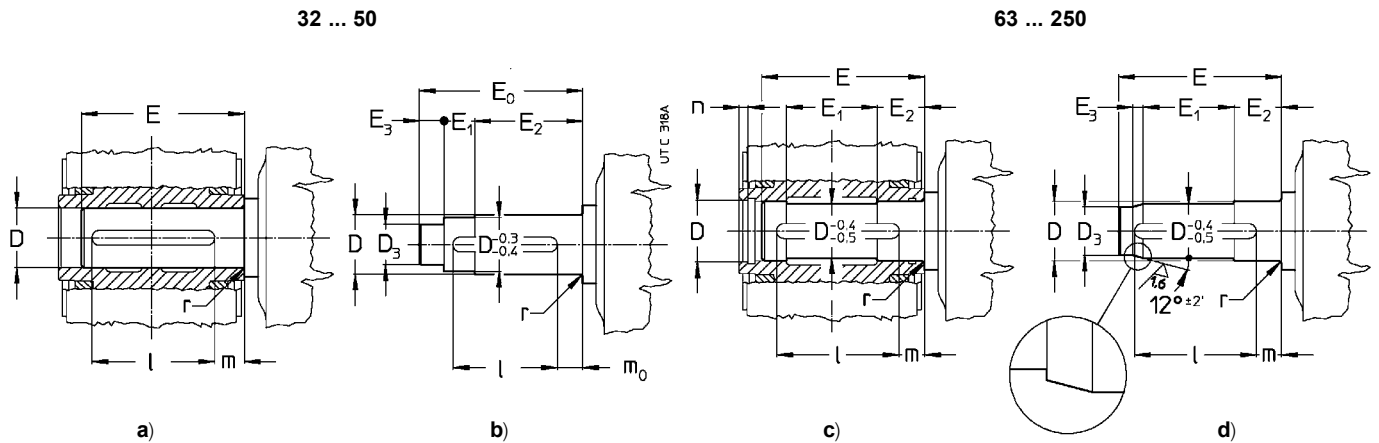
Dimensions of shaft end to which the gear reducer's hollow shaft is to be keyed are those recommended in the table on following page and shown in the figures below.

Sizes 32 ... 50: fitting with key (fig. a) or fitting with key and locking rings (fig. b).

Sizes 63 ... 250: fitting with key (fig. c) or fitting with key and locking bush (fig. d); see also ch.4 and 5.

In the case of cylindrical shaft end with only diameter D (fig. a, c), for the seat D on input side, we recommend tolerance h6 or j6 instead of j6 or k6 to facilitate mounting.

**Important** the shoulder diameter of the shaft end of the driven machine abutting with the gear reducer must be at least  $(1,18 \div 1,25) \cdot D$ .



Gear reducer size	D	D <sub>3</sub>	E	E <sub>0</sub>	E <sub>1</sub>	E <sub>2</sub>	E <sub>3</sub>	l	m	m <sub>0</sub>	n	r
	∅ H7/j6, k6	∅ H7/h6										
32	19	15	62,5	67	0	59	8	36	21	19,5	—	1,5
40	24	19	76,5	81	13	54	14	45	23,5	18,5	—	1,5
50	28	24	87	91,5	16,5	61	14	63	21,5	11	—	1,5
63, 64	32	27	110	—	57	34	10	70	28	—	6	1,5
80	38	32	134	—	71	39,5	12	90	30	—	6	1,5
81	40	34	134	—	71	39,5	12	90	30	—	6	1,5
100	48	41	162	—	87	46,5	14	110	35	—	7	2
125, 126	60	52	193	—	102	55	16	140	32	—	7	2
160	70	62	228	—	124	63	16	180	35	—	8	2
161	75	66	228	—	124	63	18	180	35	—	8	2
200	90	80	274	—	150	75	21	200	50	—	9	3
250	110	98	331	—	180	90	25	250	55	—	10	3

## Maximum bending moment of flange MR

In case of assembly of motors supplied by the customer, verify that the static bending moment  $M_b$  generated by motor weight on the counter flange of gear reducer is lower than the value allowed  $M_{bmax}$  stated in the table:

$$M_b \leq M_{bmax}$$

where:

$$M_b = G \cdot (X + HF) / 1000 \text{ [daN m]}$$

G [daN] motor weight; numerically nearly equal to motor mass, expressed in kg

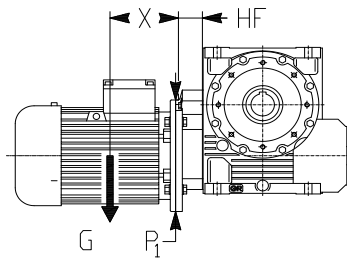
X [mm] distance from motor center of gravity from flange surface

HF [mm] given in the table, according to gear reducer size and flange diameter  $P_1$ .

Very long and thin motors, though with bending moments within the prescribed limits, may generate anomalous vibrations during the operation. In these cases it is necessary to foresee a proper additional motor support (see motor specific documentation).

**Loads higher than permissible loads may be present in dynamical applications** where the gearmotor is subjected to translations, rotations or oscillations (e.g.: **shaft mounting arrangements**): consult us for the study of every specific case

Max allowable bending moment to  $M_{bmax}$  and HF dimension

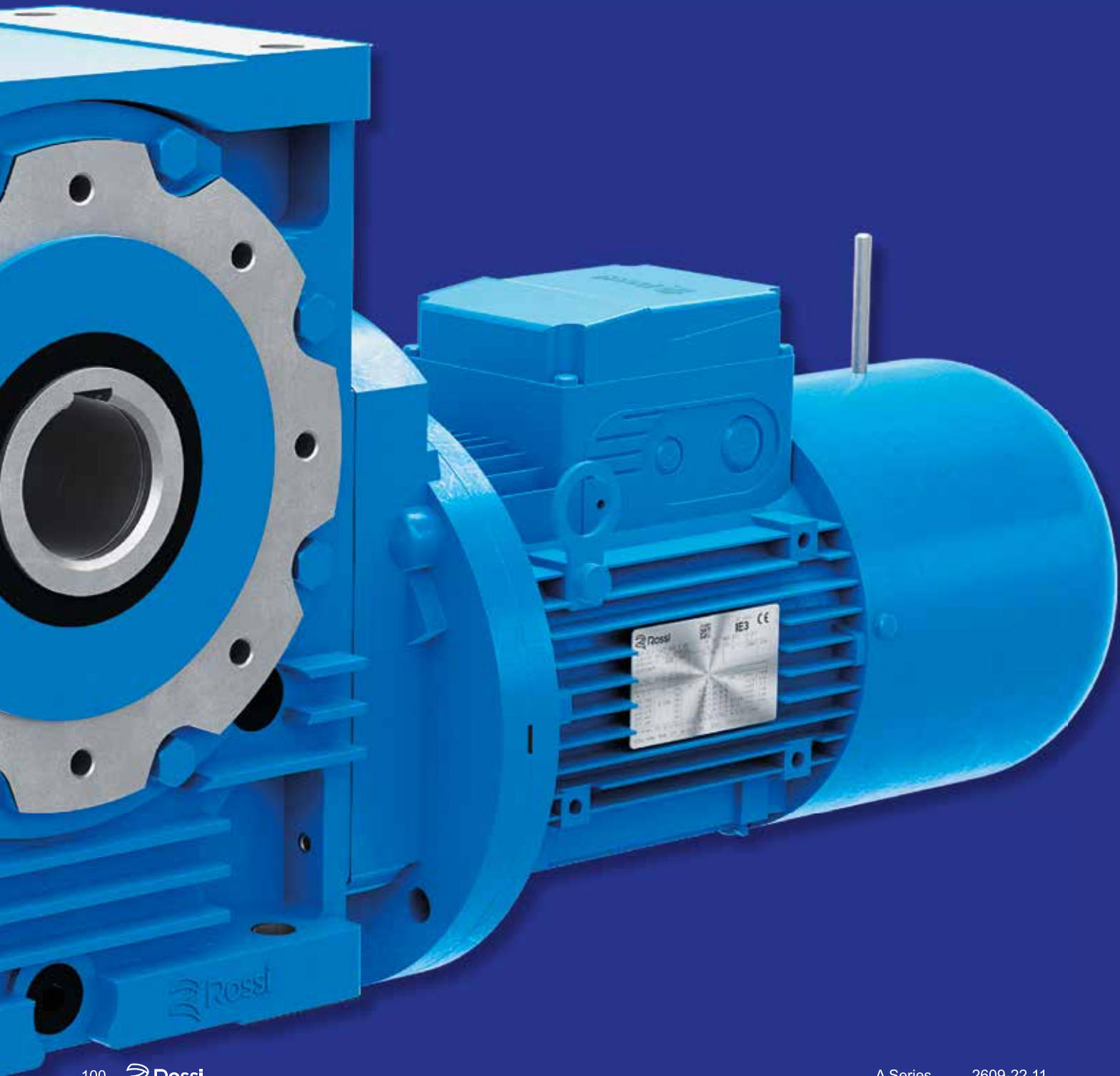


Gear reducer size	$P_1$ ∅	V, IV		2IV	
		HF mm	$M_{bmax}$ daN m	HF mm	$M_{bmax}$ daN m
<b>32</b>	140	28	<b>5,6</b>	–	–
	160	30	<b>5,6</b>	–	–
<b>40, 50</b>	140	31	<b>6,3</b>	50	<b>6,3</b>
	160	31	<b>6,3</b>	50	<b>6,3</b>
	200	43	<b>6,3</b>	–	–
<b>63 ... 81</b>	160	38	<b>11,2</b>	65	<b>11,2</b>
	200	38	<b>11,2</b>	65	<b>11,2</b>
	250	38	<b>11,2</b>	–	–
<b>100</b>	200	45	<b>28</b>	78	<b>28</b>
	250	45	<b>28</b>	–	–
	300	65	<b>28</b>	–	–
<b>125, 126</b>	200	55	<b>50</b>	99	<b>50</b>
	250	55	<b>50</b>	99	<b>50</b>
	300	56	<b>56</b>	–	–
<b>160 ... 200</b>	250	67	<b>100</b>	–	–
	300	67	<b>100</b>	–	–
	350	80	<b>112</b>	–	–
	400	80	<b>112</b>	–	–
<b>250</b>	300	80	<b>180</b>	–	–
	350	80	<b>180</b>	–	–
	400	80	<b>180</b>	–	–
	450	90	<b>200</b>	–	–

blank page

# 4

# Installation and maintenance





## Section content

4.1	General	102
4.2	Lubrication	104
4.3	Shaft mounting arrangements	105
4.4	Motor replacement	106

## 4.1- General

Be sure that the structure on which gear reducer or gearmotor is fitted is plane, levelled and sufficiently dimensioned in order to assure fitting stability and vibration absence, keeping in mind all transmitted forces due to the masses, to the torque, to the radial and axial loads.

Position the gear reducer or gearmotor so as to allow a free passage of air for cooling both gear reducer and motor (especially at gear reducer and motor fan sides).

Avoid: any obstruction to the air-flow; heat sources near the gear reducer that might affect the temperature of cooling-air and of gear reducer for radiation; insufficient air recycle or any other factor hindering the steady dissipation of heat.

Mount the gear reducer so as not to receive vibrations.

When external loads are present use pins or locking blocks, if necessary.

When fitting gear reducer and machine and/or gear reducer and eventual flange **B5** it is recommended to use **locking adhesives** such as LOCTITE on the fastening screws (also on flange mating surfaces).

For outdoor installation or in a hostile environment protect the gear reducer or gearmotor with anticorrosion paint. Added protection may be afforded by water-repellent grease (especially around the rotary seating of seal rings and the accessible zones of shaft end).

Gear reducers and gearmotors should be protected wherever possible, and by whatever appropriate means, from solar radiation and extremes of weather; weather protection **becomes essential** when high or low speed shafts are vertically disposed, or where the motor is installed vertical with fan uppermost.

For ambient temperatures greater than 40 °C or less than 0 °C, consult us.

Before wiring-up the gearmotor, make sure that motor voltage corresponds to input voltage. If the direction of rotation is not as desired, invert two phases at the terminals.

Star-delta starting should be adopted for starting on no load (or with a very small load) and/or when the necessity is for smooth starts, low starting current and limited stresses.

If overloads are imposed for long periods of time, or if shocks or danger of jamming are envisaged, then motor-protections, electronic torque limiters, fluid couplings, safety couplings, control units or other suitable devices should be fitted.

Where duty cycles involve a high number of starts on-load, it is advisable to utilize **thermal probes** (fitted on the wiring) for motor protection; a thermal overload relay is unsuitable since its threshold must be set higher than the motor's nominal current rating.

Use varistors to limit voltage peaks due to contactors.

**Caution! Bearing life, good shaft and coupling running depend on alignment precision between the shafts.** Carefully align the gear reducer with the motor and the driven machine (with the aid of shims if need be), interposing flexible couplings whenever possible.

Whenever a leakage of lubricant could cause heavy damages, increase the frequency of inspections and/or envisage appropriate control devices (e.g.: remote oil level gauge, lubricant for food industry, etc.).

In polluting surroundings, take suitable precautions against lubricant contamination through seal rings or other.

Gear reducer or gearmotor should not be put into service before it has been incorporated on a machine which is conform to 2006/42/EC directive.

For brake or special motors, consult us for specific information.

### Fitting of components to shaft ends

It is recommended that the bore of parts keyed to shaft ends is machined to H7 tolerance; G7 is permissible for high speed shaft ends  $D \geq 55$  mm, provided that load is uniform and light; for low speed shaft ends, tolerance must be **K7** when load is not uniform and light. Other details are given in the «Shaft end» table (ch. 3.13).

Before mounting, clean mating surfaces thoroughly and lubricate against seizure and fretting corrosion.

Installing and removal operations should be carried out with **pullers** and **jacking screws** using the tapped hole at the shaft butt-end; for H7/m6 and K7/j6 fits it is advisable that the part to be keyed is pre-heated to a temperature of  $80 \div 100$  °C.



## Hollow low speed shaft

For the shaft end of machines where the hollow shaft of the gear reducer is to be keyed, j6 or k6 tolerances are recommended (according to requirements). Other details are given under «Shaft end» and «Shaft end of driven machine» (ch. 3.13).

In order to have an easier installing and removing of gear reducer sizes 63 ... 250 (with circlip groove) proceed as per the drawings a, b, respectively.

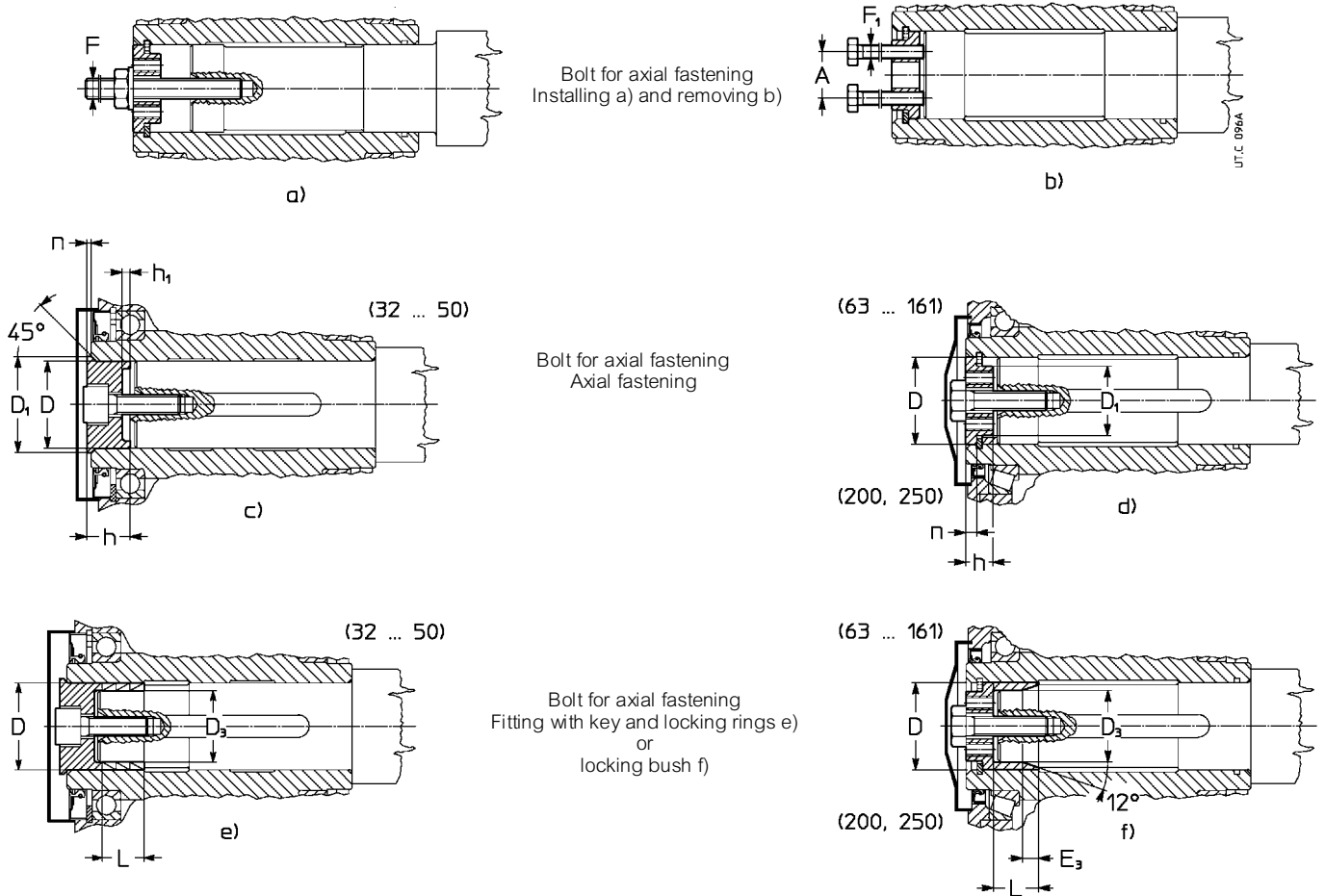
The system illustrated in the fig. c, d is good for axial fastening.

For sizes 63 ... 250, when shaft end of driven machine has no shoulder a spacer may be located between the circlip and the shaft end itself (as in the lower half of the fig. d).

The use of **locking rings** (sizes 32 ... 50, fig. e), or of **locking bush** (sizes 63 ... 250, fig. f) will permit easier and more accurate installing and removing and to eliminate backlash between key and keyway.

The locking rings or the locking bush are fitted after mounting, the shaft end of the driven machine must be as prescribed at ch. 3.13. Do not use molybdenum bisulphide or equivalent lubricant for the lubrication of the parts in contact. We recommend the use of a **locking adhesive** such as LOCTITE 601. For vertical ceiling-type mounting, contact us.

A **washer** for installing, removing (excluding sizes 32 ... 50) and axial fastening of gear reducer (ch. 5) with or without **locking rings** or **locking bush** (dimensions shown in the table) and a **protection cap** for the hollow low speed shaft can be supplied on request. Parts in contact with the circlip must have sharp edges.



Gear reducer size	A	D Ø	D <sub>1</sub> Ø	D <sub>3</sub> Ø	E <sub>3</sub> ≈	F	F <sub>1</sub>	h	h <sub>1</sub>	L	n	Bolt for axial fastening	
												UNI 5737-88	M [daN m] <sup>3)</sup>
32	—	19	22,5	15	—	—	—	14,8	2,8	6,3	1,1	M 8 × 25 <sup>1)</sup>	2,9
40	—	24	27,5	19	—	—	—	14,8	2,8	12,6	1,2	M 8 × 25 <sup>1)</sup>	3,2
50	—	28	32	24	—	—	—	18,5	3,2	12,6	1,2	M 10 × 30 <sup>1)</sup>	4,3
63,64	18	32	23	27	9	M 10	M 6	10	—	19	6	M 10 × 35	4,3
80	18	38	27	32	11	M 10	M 6	12	—	23	6	M 10 × 35	5,3
81	18	40	28	34	11	M 10	M 6	12	—	23	6	M 10 × 35	5,3
100	23	48	35	41	13	M 12	M 8	14	—	28	7	M 12 × 45	9,2
125, 126	30	60	45	52	15	M 14	M 10	16	—	35	7	M 14 × 45	17
160	36	70	54	62	15	M 16	M 12	19	—	40	8	M 16 × 50	21
161	36	75	59	66	17	M 16	M 12	19	—	40	8	M 16 × 50 <sup>3)</sup>	21
200	49	90	72	80	20	M 20	M 16	23	—	49	9	M 20 × 60 <sup>2)</sup>	43
250	64	110	89	98	24	M 24	M 16	24	—	60	10	M 24 × 70 <sup>2)</sup>	83

1) UNI 5931-84.

2) For locking bush: M 20 × 65 and M 24 × 80 UNI 5737-88 class 10.9.

3) Tightening torque for locking rings or bush.

## 4.2 - Lubrication

Gear pairs and bearings on worm are oil-bath lubricated; sizes 200 and 250 mounting position B7 with worm speed  $> 710 \text{ min}^{-1}$  have upper bearings on worm lubricated by a pump inside the casing. Other bearings are likewise lubricated by oil-bath, or splashed, with the exception of upper-bearings on wormwheel in mounting position V5 and V6, where life-grease lubrication is employed (NILOS ring in sizes 161 ... 250).

**All sizes** are envisaged with **synthetic oil** lubrication.

Synthetic oil can withstand temperature up to **95 ÷ 110 °C**.

**Sizes 32 ... 81:** gear reducers are supplied filled with synthetic oil (KLÜBER Klübersynth GH 6-320, MOBIL Glygoyle 320, SHELL Omala S4 WE 320; when worm speed  $< 280 \text{ min}^{-1}$  KLÜBER Klübersynth GH 6-680), providing **«long life»** lubrication, assuming pollution-free surroundings; quantities as indicated in ch. 8 and 10, and on the lubrication plate. Ambient temperature  $0 \div 40 \text{ °C}$  with peaks of  $-20 \text{ °C}$  and  $+50 \text{ °C}$ .

**Important:** verify mounting position keeping in mind that if gear reducer is installed in a mounting position which differs from the one indicated on the name plate, it could require the addition of the difference between the two quantities of lubricant given in ch. 3.6 and 3.8, by way of the housing filler hole.

**Sizes 100 ... 250:** gear reducers are supplied without oil; before putting into service, fill to the specified level<sup>1)</sup> with polyglycol basis (PAG) synthetic oil having the ISO viscosity-grade given in the table. Under normal conditions, the first speed range is for train of gears **V**, the second **IV** and **V**, (low speed), and the third **combined units** and **V, IV, 2IV** (low speed).

1) Lubricant quantities stated on ch. 3.6 and 3.8 are approximate for provisioning. The exact oil quantity the gear reducer is to be filled with is definitely given by the level.

Produttore Manufacturer	Olio sintetico PAG PAG synthetic oil
AGIP	Blasia S
ARAL	Degol GS
BP	Enersyn SG-XP
CASTROL	Optiflex A
FUCHS	Renolin PG
KLÜBER	Klübersynth GH6
MOBIL	Mobil Glygoyle
SHELL	Omala S4 WE
TEXACO	Synlube CLP
TOTAL	Carter SY

ISO viscosity grade

Mean kinematic viscosity [cSt] at 40 °C.

Velocità vite Worm speed $\text{min}^{-1}$	Temperatura ambiente $0 \div 40 \text{ °C}^{1)}$ – Olio sintetico / Ambient temperature $0 \div 40 \text{ °C}^{1)}$ – Synthetic oil					
	Grandezza riduttore - Gear reducer size					
	100	125 ... 161		200, 250		
		B3, V5, V6	B6, B7, B8	B3, V5, V6	B6, B7, B8	
<b>2 800 ÷ 1 400</b> <sup>2)</sup>	320	320	220	220		
<b>1 400 ÷ 710</b> <sup>2)</sup>	320	320		320	220	
<b>710 ÷ 355</b> <sup>2)</sup>	460	460		460	320	
<b>355 ÷ 180</b> <sup>2)</sup>	680	680	460	460		
<b>&lt; 180</b>	680	680		680		

1) Peaks of  $10 \text{ °C}$  above and  $10 \text{ °C}$  ( $20 \text{ °C}$  for  $\leq 460 \text{ cSt}$ ) below the ambient temperature range are acceptable.

2) For these speeds we advise to replace oil after running-in.

**Combined gear reducer and gearmotor units:** lubrication remains independent, thus data relative to each single gear reducer hold good.


An overall guide to **oil-change interval**, is given in the table, and assumes pollution-free surroundings. Where heavy overloads are present, halve the value.

Temperatura olio [°C]	Intervallo di lubrificazione [h] - Olio sintetico	Oil temperature [°C]	Oil-change interval [h] - Synthetic oil
$\leq 65$	18 000	$\leq 65$	18 000
<b>65 ÷ 80</b>	12 500	<b>65 ÷ 80</b>	12 500
<b>80 ÷ 95</b>	9 000	<b>80 ÷ 95</b>	9 000
<b>95 ÷ 110</b>	6 300	<b>95 ÷ 110</b>	6 300

Never mix different makes of synthetic oil; if oil-change involves switching to a type different from that used hitherto, then give the gear reducer a thorough clean-out.

**Running-in:** a period of about  $400 \div 1\,600 \text{ h}$  is advisable, by which time the gear pair will have reached maximum efficiency (ch. 3.13); oil temperature during this period is likely to reach higher levels than would normally be the case.

**Sealings:** duration depends on several factors such as dragging speed, temperature, ambient conditions, etc.; as a rough guide; it can vary from 3 150 to 25 000 h.

**Warning:** for gear reducers sizes 100 ... 250, before unscrewing the filler plug with valve (symbol ) wait until the unit has cooled and then open with caution.

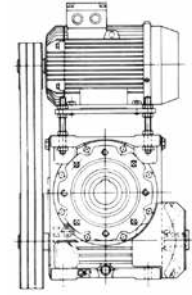
## 4.3 - Shaft-mounting arrangements

The strength and shape of the housing offer: **advantageous** possibilities for shaft mounting even – for instance – in the case of gearmotor with belt drive.

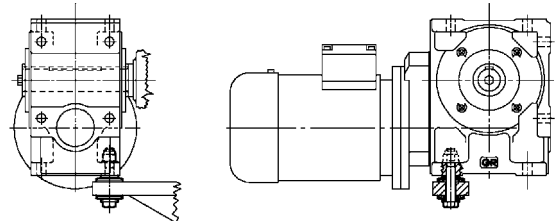
A few shaft mounting arrangements are shown here with the relative details as to selection, and installation.

In ch. 3.4 are shown the shaft-mounting arrangements which **can be supplied**.

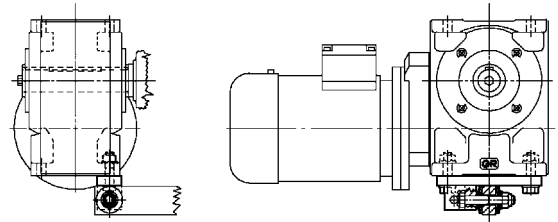
**IMPORTANT.** When shaft mounted, the gearmotor must be supported both axially and radially by the shaft end of the driven machine, as well as anchored against rotation only, by means of a reaction having **freedom of axial movement** and sufficient **clearance in its couplings** to permit minor oscillations – always in evidence – without provoking dangerous overloads on the actual gearmotor. Pivots and components subject to sliding have to be properly lubricated; we recommend the use of a locking adhesive such as LOCTITE 601 when fitting the bolts.



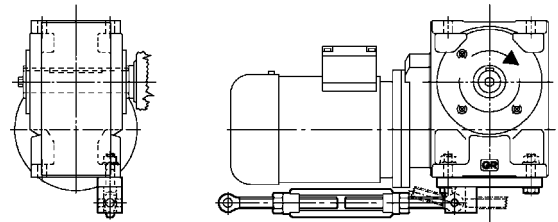
For sizes 32 ... 126 can be supplied (ch. 3.4) a semi-flexible and economical reaction arrangement, with bolt using disc springs.



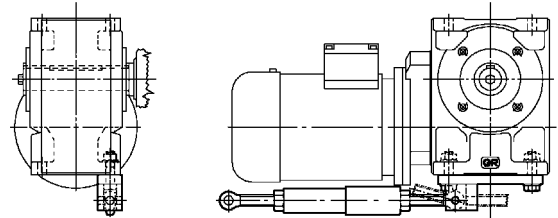
Semi-flexible reaction arrangement for sizes 63 ... 250 (ch. 5) using disc springs and bracket.



Rigid reaction arrangement for variable-distance anchorage for sizes 63 ... 250 (ch. 5) using a torque arm. Where direction of rotation is opposite to the one shown in the drawing, turn the torque arm through 180°.

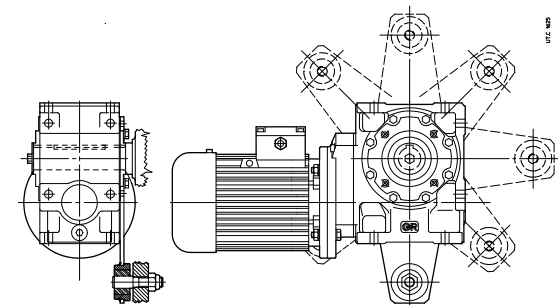


Similar to the previous arrangement for sizes 100 ... 250 (ch. 5), but using a flexible torque arm; safety devices may be installed to prevent accidental overloads. The flexible torque arm may be turned through 180° regardless of direction of rotation.

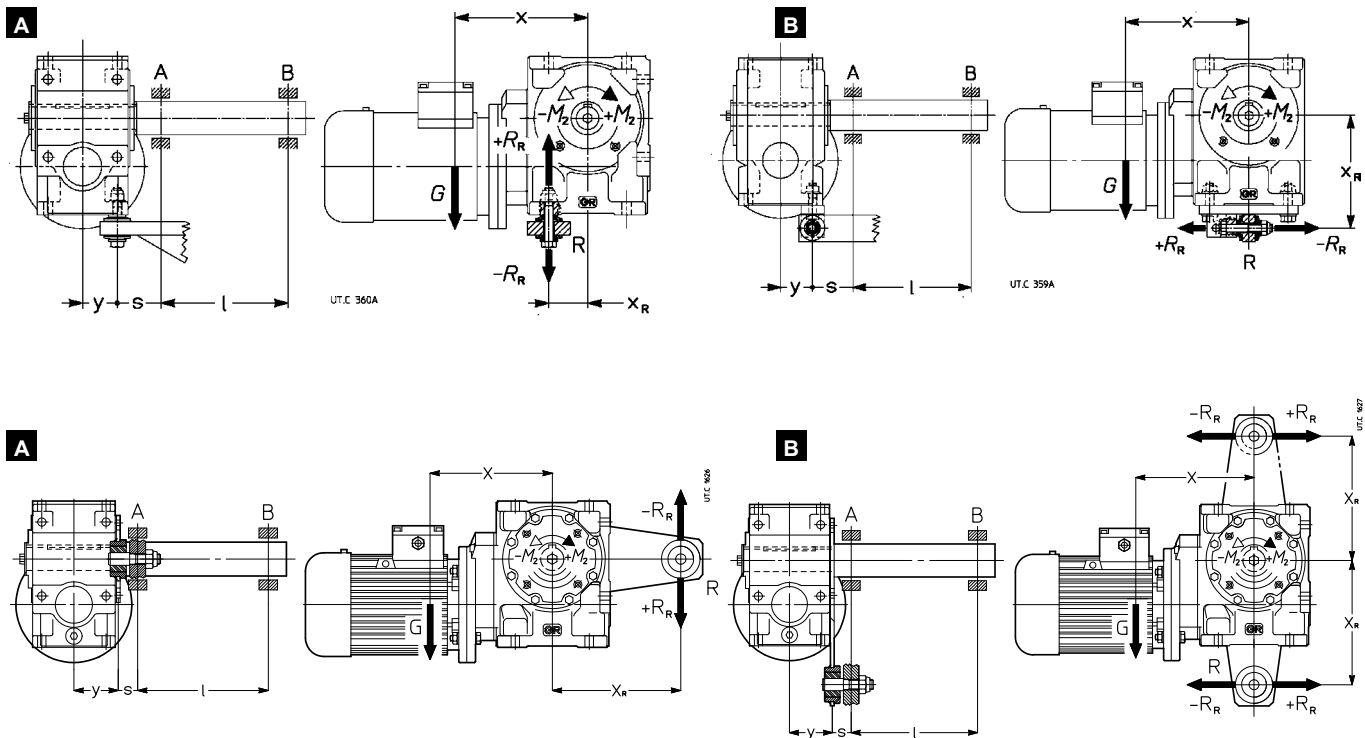


UTC 748

Reaction arrangement using torque arm, fitted onto B14 flange, with plastic damping bush (see ch. 5).



For the majority of normal cases, where weight force  $G$  is orthogonal or parallel to reaction  $R_R$  as illustrated in the drawings, reactions are calculated thus:



1) reaction  $R_R$  [daN] produced by support R:

$$R_R = (1 / x_R) \cdot [G \cdot x + (\pm M_2)]$$

2) bending moment  $M_{iA}$  [daN m] through the cross-section of bearing A:

**A**  $M_{iA} = [G \cdot (y + s)] - [(\pm R_R) \cdot s]$

**B**  $M_{iA} = \sqrt{[G \cdot (y + s)]^2 + [R_R \cdot s]^2}$

3) bearing A radial reaction  $R_A$  [daN]:

**A**  $R_A = \frac{1}{l} \{ [G \cdot (y + s + l)] - [(\pm R_R) \cdot (s + l)] \}$

**B**  $R_A = \frac{1}{l} \sqrt{[G \cdot (y + s + l)]^2 + [R_R \cdot (s + l)]^2}$

4) bearing B radial reaction  $R_B$  [daN]:

$$R_B = \frac{M_{iA}}{l}$$

where:

- $G$  [daN]: weight force almost equal numerically to gearmotor mass (ch.3.8);
- $M_2$  [daN m]: output torque expressed by + or - according to the direction of rotation in the drawing;
- $x$  [m]: dimension to  $x = G + 0,2 \cdot Y$  (ch. 3.8);
- $y$  [m]: dimension  $y = 0,5 \cdot B$  (ch. 3.8);
- $x_R$  [m] (for reaction bolt with disc spring): dimension  $x_R = 0,5 \cdot A$  (drawing on the left) or  $x_R = H + S$  (drawing on the right) (ch. 3.8 and 5);
- $x_r$  [m] (for torque arm): see table at ch. 5;
- $l, s$  [m]: dimension  $s$  must be as short as possible.

## 4.4 - Motor replacement

As all gearmotors are fitted with **standard** motors, motor replacement is extremely easy. Simply observe the following instructions:

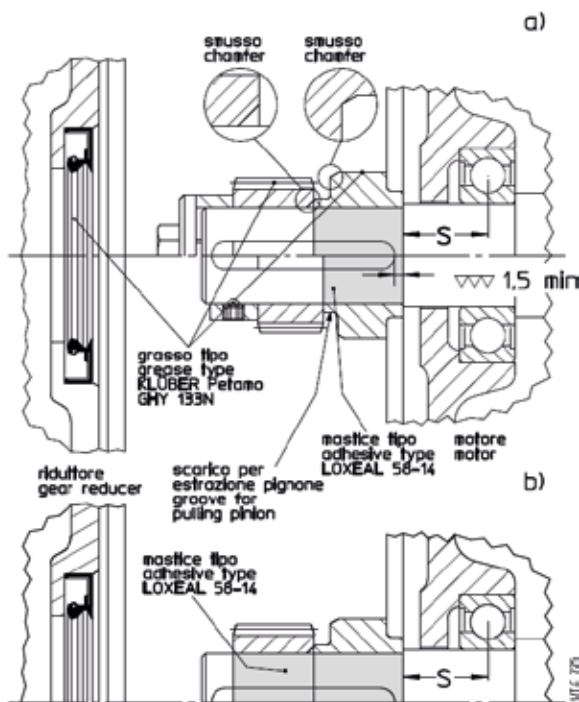
- be sure that the mating surfaces are machined under accuracy rating (IEC 60072-1);
- clean surfaces to be fitted thoroughly;
- in the event of a lowered keyway, replace the motor keyway with the one supplied with the gear reducer; adjust the keyway length to the motor shaft, if need be; check that between the top and the bottom of the hole keyway there is a backlash of 0,1 - 0,2 mm; in the event of output shaft keyway, lock the key by pins.

### for MR V:

- check that the fit-tolerance (push-fit) between holes hole-shaft end is G7/j6 for  $D < 28$  mm, F7/k6 for  $D > 38$  mm;
- lubricate surfaces to be fitted against fretting corrosion;

### For MR IV, 2IV

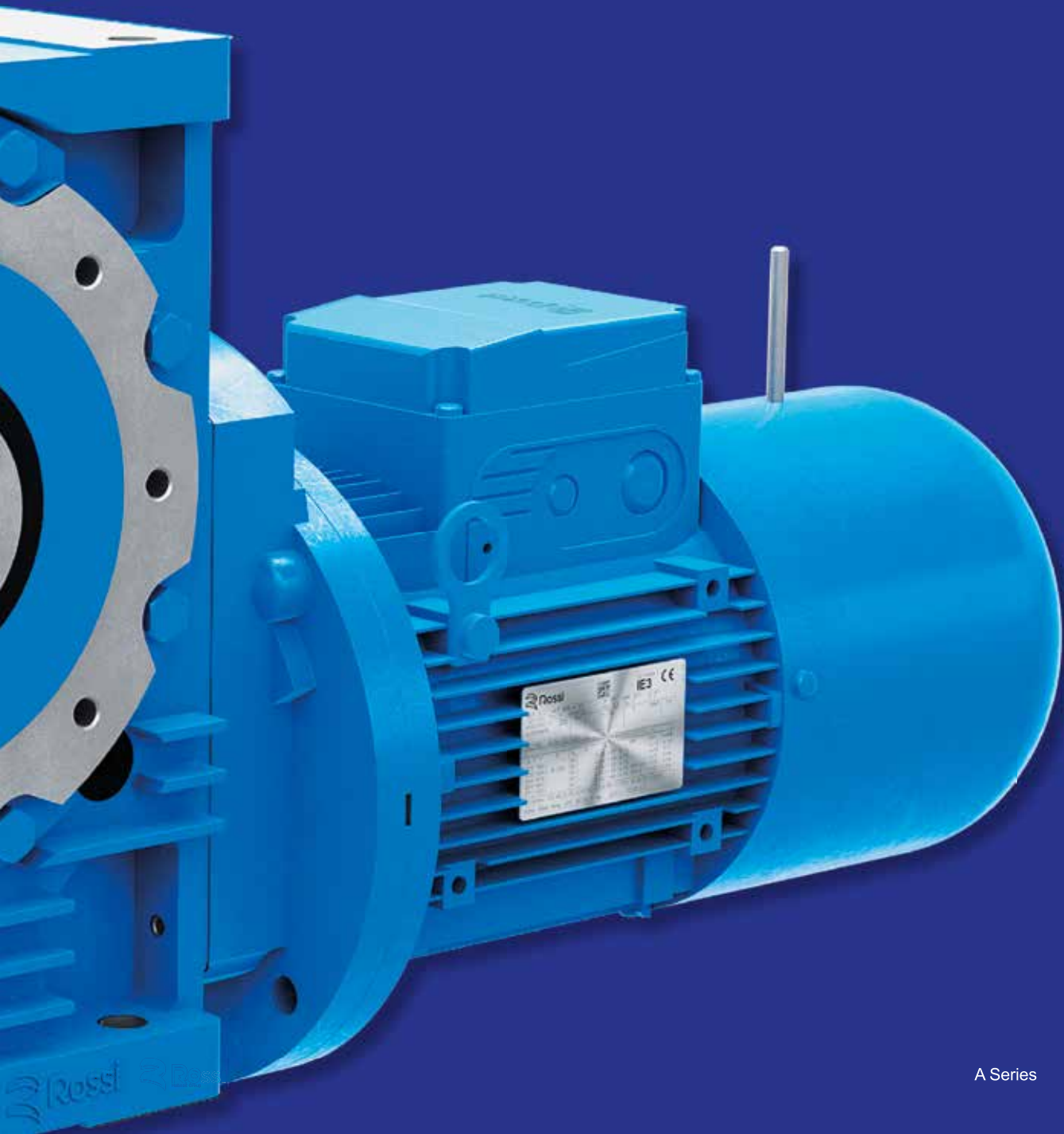
- check that the fit-tolerance (push-fit) between hole and shaft end is K6/j6 for  $D \leq 28$  mm, J6/k6 for  $D \geq 38$  mm;
- make sure that the motors have bearing location and overhang (distance S) as shown in the table;



Motor size	Min. dynamic load capacity [daN]		Max dimension 'S' mm
	Front	Rear	
63	450	335	16
71	630	475	18
80	900	670	20
90	1 320	1 000	22,5
100	2 000	1 500	25
112	2 500	1 900	28
132	3 550	2 650	33,5
160	4 750	3 350	37,5
180	6 300	4 500	40
200	8 000	5 600	45
225	10 000	7 100	47,5

- assemble on motor shaft, as follows:
  - the **spacer** pre-heated at **65 °C** sealing the motor shaft part with **locking adhesive type LOXEAL 58-14** and ensuring that between keyway and motor shaft shoulder there is a ground cylindrical section of at least 1,5 mm; pay attention **not to damage the external surface of spacer**;
  - the **key** in the keyway, taking care that a brief segment of at least 0,9 times the pinion width;
  - the pinion pre-heated at **80 ÷ 100 °C**;
  - the **axial fastening system** where foreseen (head self-locking screw with base, spacer, or hub clamp with one or more dowels, fig. a); for the cases foreseen **without axial fastening** (fig. b), seal with **locking adhesive type LOXEAL 58-14** also the motor shaft section below the **pinion**;
- in the event of axial fastening system with hub clamp and dowels, be sure that these ones do not overhang from spacer external surface: screw the dowel and matrix the motor shaft with a tip;
- grease the pinion teeth, the sealing ring rotary seat and the seal ring (with KLÜBER Petamo GHY 133N), and assemble carefully, **paying attention not to damage the seal ring lip due to accidental shock with the pinion toothing**.

# Accessories and non-standard designs



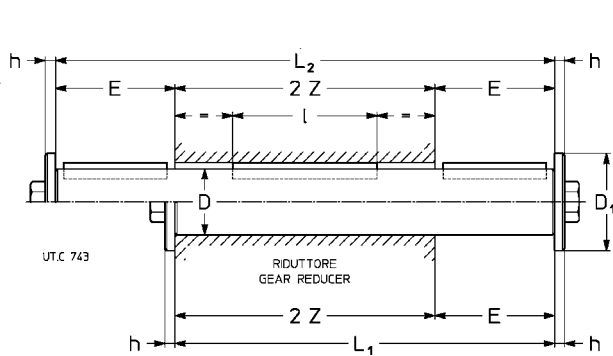


## Section content

<b>5.1</b>	Low speed shafts	110
<b>5.2</b>	Solid low speed shaft	110
<b>5.3</b>	Oversized hollow low speed shaft	110
<b>5.4</b>	Flange	110
<b>5.5</b>	Torque arm	111
<b>5.6</b>	Hollow low speed shaft Standardfit	111
<b>5.7</b>	Strengthened low speed shaft bearings	112
<b>5.8</b>	Strengthened high speed shaft bearings	112
<b>5.9</b>	Controlled or reduced backlash	112
<b>5.10</b>	Hollow low speed shaft washer	112
<b>5.11</b>	Hollow low speed shaft washer with locking ring or bush	112
<b>5.12</b>	Hollow low speed shaft protection	112
<b>5.13</b>	Shaft mounting arrangements	113
<b>5.14</b>	Gear reducers design ATEX II GD and 3GD	114
	Miscellaneous	115

## 5.1 - Low speed shafts

Supplementary description when ordering by **designation: standard**, or **double extension low speed shaft**



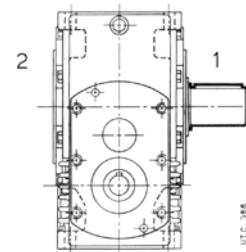
Gear reducer size	D Ø	E	D <sub>1</sub> Ø	h	L <sub>1</sub>	L <sub>2</sub>	l	2 Z	Bolt	Mass	
										Standard	Double extens.
32	19 h7	30	28	4	108	138	36	78	M 6 × 20	0,3	0,4
40	24 h7	36	35	5	128	164	45	92	M 8 × 25	0,6	0,7
50	28 h7	42	35	5	148	190	63	106	M 8 × 25	0,8	1
63, 64	32 h7	58	47	5	184	242	70	126	M 10 × 30	1,2	1,5
80	38 h7	58	47	5	208	266	90	150	M 10 × 30	1,9	2,4
81	40 h7	58	47	5	208	266	90	150	M 10 × 30	2,1	2,7
100	48 h7	82	57	6	262	344	110	180	M 12 × 40	3,7	4,9
125, 126	60 h7	105	82	8	317	422	140	212	M 16 × 45	7	9,4
160	70 j6	105	82	8	355	460	180	250	M 16 × 45	11	14
161	75 j6	105	82	8	355	460	180	250	M 16 × 45	12,6	16
200	90 j6	130	102	10	430	560	200	300	M 20 × 60	21	28
250	110 j6	165	135	12	525	690	250	360	M 24 × 60	39	51

The shoulder outer diameter of the part, or of spacer abutting with the gear reducer must be  $(1,25 \div 1,4) \cdot D$ .

## 5.2 - Solid low speed shaft (size 250)

In order to permit the high radial loads given in the catalog (250 bis), the gear reducer size 250 can be supplied with solid low speed shaft and strengthened bearings. Dimensions remain unchanged (missing the washer on shaft end).

Supplementary description when ordering by **designation: solid low speed shaft pos. 1** or **2** or **double extension**.



## 5.3 - Oversized hollow low speed shaft

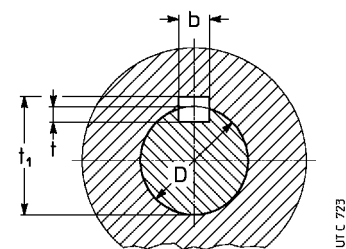
The gear reducers and gearmotors sizes 32 ... 64 and 100 can be supplied with oversized hollow low speed shaft; dimensions are according to table on the left.

Gear reducer size	D Ø	Parallel key b x h x l*	Keyway		
			b	t	t <sub>1</sub>
32	20	6 × 6 × 36	6	4 <sup>1)</sup>	22,2 <sup>1)</sup>
40	25	8 × 7 × 45	8	4,5 <sup>1)</sup>	27,7 <sup>1)</sup>
50	30	8 × 7 × 63	8	5 <sup>1)</sup>	32,2 <sup>1)</sup>
63 <sup>2)</sup> , 64 <sup>2)</sup>	35	10 × 8 × 90	10	6 <sup>1)</sup>	37,3 <sup>1)</sup>
100	50	14 × 9 × 110	14	5,5 <sup>1)</sup>	53,8

\* Recommended length.

1) Not unified values.

2) Without circlip groove.



Supplementary description when ordering by **designation: oversized hollow low speed shaft**

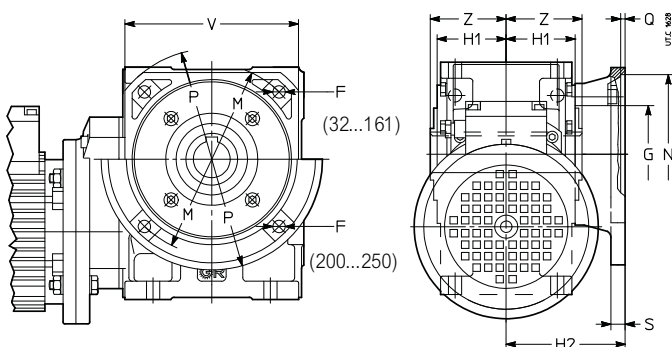
## 5.4 - Flange

B5 flange having clearance holes and spigot «recess».

Available in 2 different options with different mating dimensions: **B5 flange** and **B5 flange Type B**

The accessory is supplied fitted onto the gear reducer. If not differently stated, the standard mounting position is on the gear reducer right side - seen from motor side. For reverse mounting, specify in designation «**mounted on opposite side**».

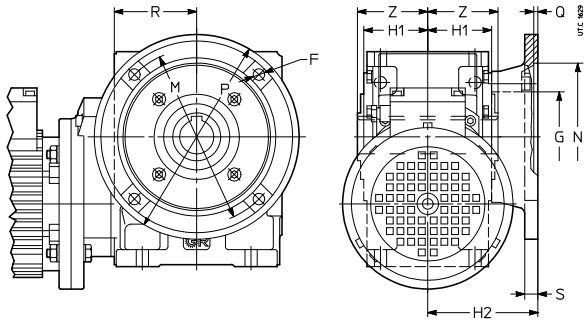
Locking adhesives are recommended both around threads and on mating surface.



### B5 flange

Grandezza riduttore Gear reducer size	F Ø	G Ø	H <sub>1</sub>	H <sub>2</sub>	M Ø	N Ø	P	Q	S	V	Z	Massa Mass kg
32	7	55	34,5	71	100	80	120	4	10	95	39	0,5
40	9,5	68	41,5	80	115	95	140	4	11	110	46	0,8
50	9,5	85	49	80	130	110	160	4,5	12	125	53	1
63, 64	11,5	80	58,5	100	165	130	200	4,5	14	152	63	2
80, 81	14	110	69,5	112	215	180	250	5	16	196	75	3,2
100	14	130	84,5	132	265	230	300	5	18	248	90	5,5
125, 126	18	180	99,5	150	300	250	350	6	20	290	106	8,5
160, 161	18	230	118,5	180	350	300	400	6	22	350	125	13
200	18 <sup>8)</sup>	250	137,5	200	400	350	450	6	22	—	150	20
250	22 <sup>8)</sup>	350	163	236	500	450	550	6	25	—	180	31





## B5 flange type B

Gear reducer size	F Ø	G Ø	H <sub>1</sub> h12	H <sub>2</sub> h12	M Ø	N Ø	P Ø	Q	R	S	Z	Mass
<b>32</b>	9,5	55	34,5	75	87	60	110	5	-	9	39	0,8
<b>40</b>	11,5	68	41,5	82	150	115	180	5	80	11	46	1,7
<b>50</b>	14	85	53	98	165	130	200	5	91	12	53	2,4
<b>63, 64</b>	14	80	63,5	107	176	152	210	6	-	14	63	2,9
<b>80, 81</b>	14	110	74,5	129	230	170	280	6	121	16	75	5,8

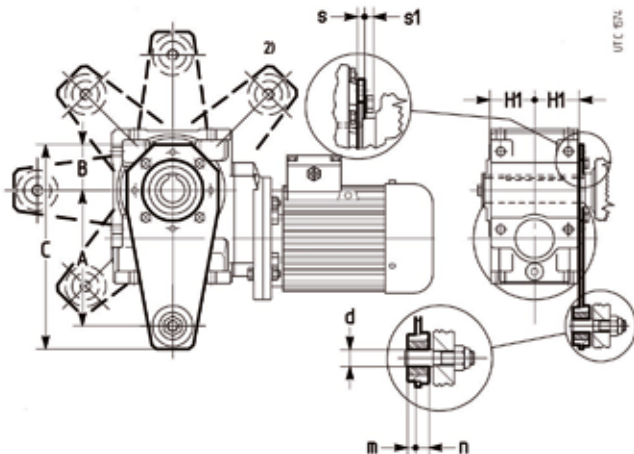
Supplementary description when ordering by **designation: flange B5 or B5 flange type B.**

In case of separate order from the gear reducer's one, the accessory designation must include the catalog and reducers size data.

## 5.5 - Torque arm

See technical explanations at ch. 4.

The accessory, including fixing bolts for gear reducer, is supplied not assembled. Fitting towards motor is not possible.



Gear reducer size	A	B	C	d Ø	H <sub>1</sub> h11	m h12	n	s	s <sub>1</sub> ≈	x <sub>R</sub> m	M <sub>2</sub> daN m
<b>32</b>	100	45	157	8 <sup>1)</sup>	31,5	5	9	4	4,7	0,100	9,5
<b>40</b>	150	52,5	230	10	44,5	7	13	6	5,6	0,150	15
<b>50</b>	200	60	294	20	53	9,5	15,5	6	5,6	0,200	18
<b>63, 64</b>	200	60	294	20	63,5	9,5	15,5	6	7,5	0,200	33,5
<b>80, 81</b>	250	80	364	20	74,5	9,5	15,5	6	9,2	0,250	67

1) Plastic damping bush not present.

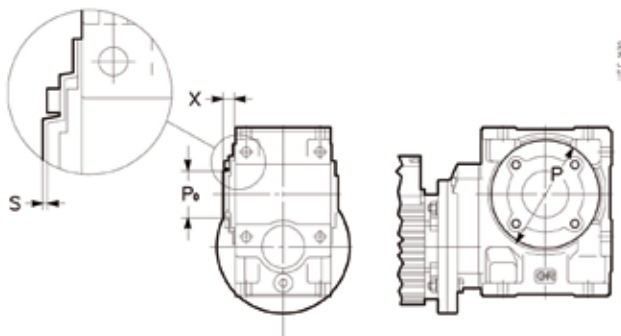
2) Position not possible for MR V 32 ... 50, MR IV 32 ... 81

Supplementary description when ordering by **designation: torque arm.**

## 5.6 - Hollow low speed shaft **STANDARDFIT** protection

Protection hollow low speed shaft free area, made of plastic (polypropilene PP material color black)

The accessory is supplied disassembled and complete with fastening screws. We recommend the use of locking adhesive on the screws.



Gear reducer size	P Ø	P <sub>0</sub> Ø	X	s H11	Screws UNI 5931	M <sub>tightening</sub> 1) N m
<b>32</b>	90	48	20,5	1,5	M5×14	1,5
<b>40</b>	105	50	20,5	1,6	M6×18	2,8
<b>50</b>	120	61	24	1,7	M6×18	2,8
<b>63, 64</b>	120	61	24	1,7	M8×20	6,3
<b>80, 81</b>	160	78	27,5	1,8	M10×20	12,3

1) Tightening torque.

Non standard design code for designation:

**Hollow low speed shaft STANDARDFIT protection**

In case of separate order from the gear reducer's one, the accessory designation must include the catalog and gear reducers size data.

## 5.7 - Strengthened low speed shaft bearings

Gear reducers and gearmotors sizes 63 ... 126 can be supplied with taper roller bearings supporting the low speed shaft, allowing increased radial and/or axial loads. Values for sizes 100 ... 126 are given in ch. 3.12, other values, consult us.

Supplementary description when ordering by **designation: strengthened low speed shaft bearings**.

## 5.8 - Strengthened high speed shaft bearings

Gear reducers R IV sizes 80 ... 126 with  $i_N \leq 160$  can be supplied with cylindrical roller bearings supporting the high speed shaft allowing increased radial loads, values **x 1,6** for sizes 80 ... 100, **x 1,4** for sizes 125 and 126 (ch. 3.11); this design is standard for sizes 160 ... 250.

Supplementary description when ordering by **designation: strengthened high speed shaft bearing**.

## 5.9 - Controlled or reduced backlash

Gear reducers and gearmotors with worm gear pair **controlled or reduced backlash**.

Values are 1/2 (controlled backlash) or 1/4 (reduced backlash) those stated on ch. 3.13; reduced backlash designed not possible for R V and MR V with input speed  $n_1 > 1\,400 \text{ min}^{-1}$ .

Supplementary description when ordering by designation: **controlled backlash** or **reduced backlash**.

## 5.10 - Hollow low speed shaft washer

All gear reducers and gearmotors can be supplied with washer, circlip (excluding sizes 32 ... 50), bolt for axial fastening and protection cap (ch. 4).

Supplementary description when ordering by **designation: hollow low speed shaft washer**.

## 5.11 - Hollow low speed shaft washer with locking rings or bush

All gear reducers and gearmotors can be supplied with washer, circlip (excluding sizes 32 ... 50), locking rings (sizes 32 ... 50) or locking bush (sizes 63 ... 250), bolt for axial fastening and protection cap (ch. 4).

Supplementary description when ordering by **designation: hollow low speed shaft washer with locking rings** or **bush**.

## 5.12 - Hollow low speed shaft protection

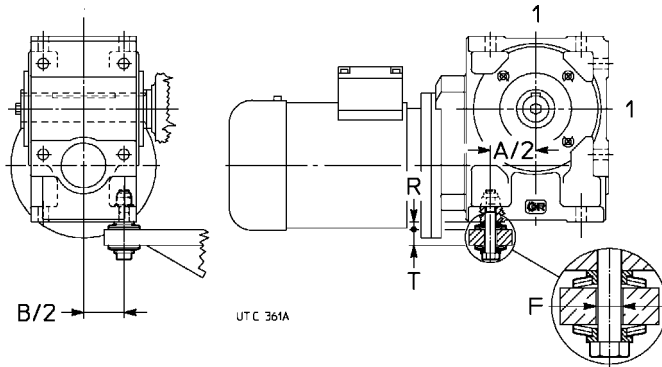
Gear reducers and gearmotors, sizes 32 ... 161, can be supplied with only the protection cap for the area not utilized by the hollow low speed shaft (ch. 4).

Supplementary description when ordering by **designation: hollow low speed shaft protection**.

## 5.13 - Shaft-mounting arrangements

See technical explanations at ch. 4.

For dimensions **A**, **B** see ch. 3.6 and 3.8.



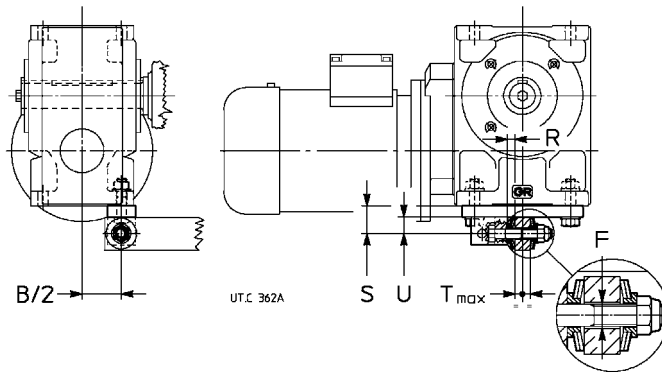
Gear reducer size	Bolt	Disc spring	T	F	R	$M_2 \leq$
	UNI 5737-88	DIN 2093		Ø	1)	daN m
32	M 6 × 40	A 18 n. 2	8 ÷ 10	8	4,9	—
40	M 8 × 55	A 25 n. 2	10 ÷ 14	11	6,5	—
50	M 8 × 55	A 25 n. 2	10 ÷ 14	11	6,5	20
63, 64	M 12 × 70*	A 35,5 n. 2	14 ÷ 17	20	8,8	31,5
80, 81	M 12 × 90	A 35,5 n. 3	18 ÷ 25	20	10,8	56
100	M 16 × 110	A 50 n. 2	23 ÷ 32	20	13,1	100
125, 126	M 16 × 110	A 50 n. 2	23 ÷ 32	20	13,1	160

1) Theoretical value: tolerance 0 ÷ -1.

2) For higher  $M_2$  values, utilize 2 reaction bolts or the arrangement with bracket (see below).  
\* Modified bolt.

It is **better** if this arrangement is applied on sides 1.

Supplementary description when ordering by **designation: reaction bolt using disc springs**.

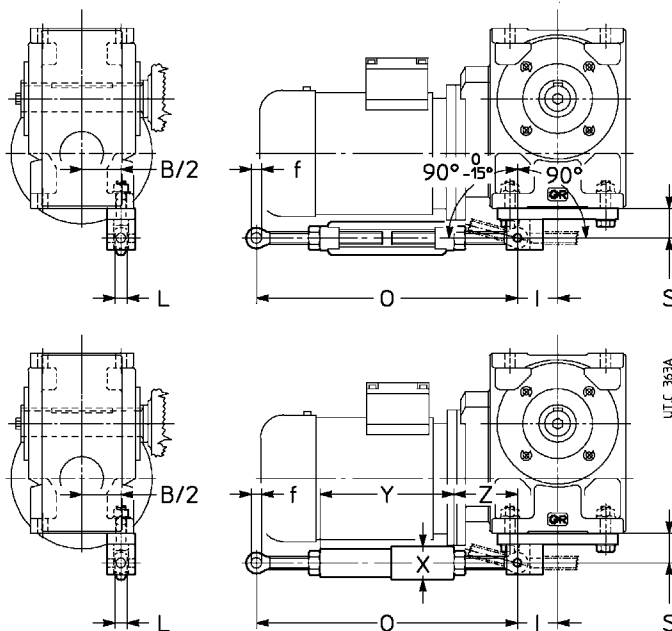


Gear reducer size	Bolt	Disc spring	T	F	S	U	R
	UNI 5737-88	DIN 2093		Ø			1)
63, 64	M 12 × 70*	A 35,5 n. 1	14 ÷ 17	20	38	23	6,8
80, 81	M 12 × 90	A 35,5 n. 2	18 ÷ 25	20	38	23	8,8
100	M 16 × 110	A 50 n. 2	25 ÷ 32	20	50	30	13,1
125, 126	M 16 × 110	A 50 n. 2	25 ÷ 32	20	50	30	13,1
160, 161	M 20 × 130	A 63 n. 3	23 ÷ 38	24	65	40	17,9
200	M 24 × 160	A 80 n. 2	29 ÷ 48	30	80	48	20,7
250	M 30 × 200	A 100 n. 2	37 ÷ 60	36	100	60	26,2

1) Theoretical value: tolerance 0 ÷ -1.

\* Modified bolt.

Supplementary description when ordering by **designation: reaction bolt using disc springs and bracket**



Gear reducer size	f	O	S	L	X	Y	Z	I
	Ø				Ø		≈	
63, 64	12	280 ÷ 350	38	14	—	—	—	50
80, 81	12	280 ÷ 350	38	14	—	—	—	56
100	16	410 ÷ 510	50	17	52	242	84	74
125, 126	16	410 ÷ 510	50	17	52	242	84	74
160, 161	22	580 ÷ 680	65	24	64	285	147	92
200	28	580 ÷ 680	80	30	88	305	137	113
250	28	580 ÷ 680	100	30	88	305	137	141

Supplementary description when ordering by **designation: rigid** (for torque arm positioning, see ch. 4) or **flexible torque arm using bracket**

## 5.14 - Gear reducer design ATEX II 2 GD and 3 GD

Worm gear reducers and gearmotors may be supplied according to European Community Directive ATEX 2014/34/EU in order to be used in potentially explosive atmospheres - category **2 GD** (for operation in zones 1 (gas), 21 (dust): presence of **probable** explosive atmosphere) and **3 GD** (for operation in zones 2 (gas) 22 (dust): **improbable** presence of explosive atmosphere) with surface temperature 135 °C (T4). These are the main variations of the product:

- fluoro-rubber seal rings;
- metal plugs; filler plug with filter and valve;
- special name plate with ATEX mark and indication of application limits;
- external protection based on a water-soluble dual-compound polyurethane **conductive** enamel, **color grey** RAL 7040, corrosivity class C3 ISO 12944-2;
- «ATEX Instructions» manual.

For category 2 GD, depending on **minimum control intervals**, also

2 GD monthly control

- double seal rings on low speed shaft;

2 GD quarterly control (sizes 200, 250)

- double seal rings on low speed shaft (size  $\geq 63$ );

- oil temperature probe;

this solution is advisable when the gear reducer has difficult access or when a decrease in control frequency is required.

Operating ambient temperature:  $-20 \div +40$  °C.

The «**ATEX Operating instructions**» (with the additional documentation, if any) are **integral part of the supply of each gear reducer**, every indication stated in it must be carefully applied. In case of necessity consult us.

### Gear reducer size selection

Determine the size of gear reducer as indicated in ch. 6 considering following additional limitations:

a) maximum input speed  $n_1 \leq 1\,500$  min<sup>-1</sup>.

b) **service factor requested** determined according to ch. 6 increased with the factors stated in the following table - **never lower than 0,85**.

Verify, at last, that the **applied power**  $P_1$  is lower than or equal to nominal thermal power  $P_{tN}$  multiplied by thermal factors  $f_{t_2}^{(1)} \dots f_{t_5}$  (see ch. 3.2) and by corrective factor  $f_{ATEX}$  given in the following table.

ATEX design **corrective factors** for required service factor **fs** and nominal thermal power **P<sub>tN</sub>**.

ATEX category	$f_{ATEX}$	$f_{ATEX}$
<b>2GD</b>	1,18	0,8
<b>3GD</b>	1,06	0,9

### Motor category selection

In the table on the right the minimum features of motors to be installed with Rossi gear reducers in ATEX design, in potentially explosive atmosphere areas.

Protection methods of electric tools:

- EEEx **e** increased safety;
- EEEx **d** flameproof enclosure;
- EEEx **de** combination of «d» and «e»;
- EEEx **nA** reduced sparking

Zone	Rossi Gear reducer ATEX II design	Required motor category <sup>1)</sup>
<b>1</b>	2 GD	2 G EEEx e 2 G EEEx d 2 G EEEx de
<b>21</b>		2 D IP65
<b>1, 21</b>		2 GD EEEx e 2 GD EEEx d 2 GD EEEx de
<b>2</b>	3 GD	3 G EEEx nA –
<b>22</b>		3 D IP54 <sup>2)</sup> –
<b>2, 22</b>		3 GD EEEx nA

1) The devices suitable for zone 1 are also suitable for zone 2, similarly the devices suitable for zone 21 are also suitable for zone 22.

2) For conductive dusts motor must be 2 D IP65.

Additional description when ordering by **designation**:

**Design ATEX II ...**

**... 3 GD T4** sizes 32 ... 250

**... 2 GD T4 monthly control** sizes 32 ... 250

**... 2 GD T4 quarterly control** sizes 200, 250

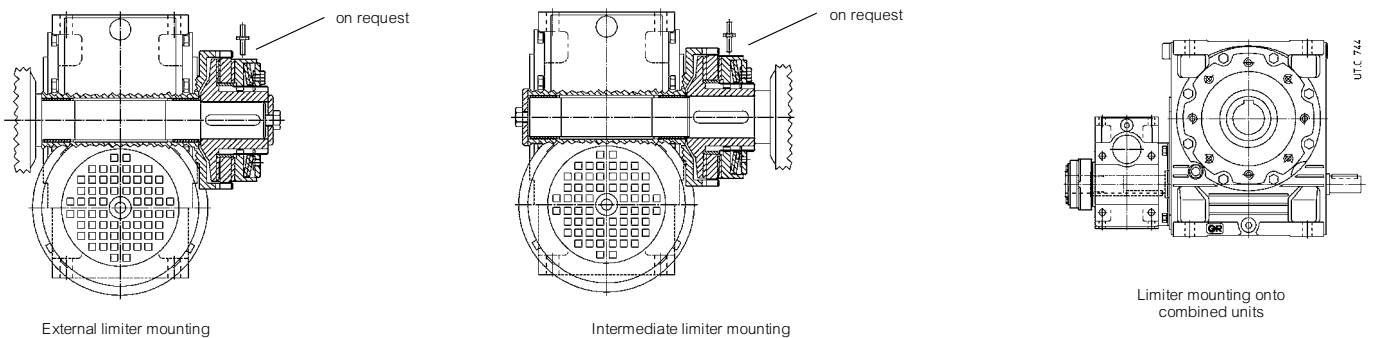
2) For gearmotors, this designation refers to the only **gear reducer part**

## Miscellaneous

- Expansion tank for continuous duty and high speed running of gear reducers and gearmotors **IV 100 ... 250** and **2IV 100 ... 126** mounting position **B6**.
- Gear reducers and gearmotors sizes **100 ... 250** supplied **filled with synthetic oil**.
- Gearmotors with:
  - **brake motor** (also single-phase) with d.c. **safety and/or parking brake** (sizes 63 ... 132) having overall dimensions nearly the same of a standard motor and braking torque  $M_f \geq M_N$ , maximum economy;
  - **two-speed motor** (standard motor, brake motors, brake motors with safety and/or parking brake, with flywheel) 2.4, 2.6, 2.8, 2.12, 4.6, 4.8, 6.8 poles;
  - **brake motor for traverse movements**: 2, 2.4, 2.6, 2.8, 2.12 poles (always with low noise d.c. brake, see picture);



- motor featuring: d.c. supply; single-phase; explosion-proof; with second shaft end; with non-standard protection, voltage and frequency; provided with devices against overloads and overheating;
- **motor without fan cooled by natural convection** (size 63 ... 112); design for textile industry.
- Gear reducers and gearmotors with **mechanical torque limiter** on **output** shaft, gear reducer sizes **32 ... 160** (excluding size 81).
- Gear reducer design with mechanical **friction** type torque limiter (friction surfaces without asbestos), compact and with high transmissible torque — up to **300 daN m** — and top quality standards.
- It protects the drive from accidental overloads by excluding the effect of inertia loads transmitted from up-line masses and, also if the gear reducer is irreversible (the torque limiter being mounted on the output shaft), inertia loads transmitted from down-line masses.
- When the transmitted torque tends to exceed the setting value the drive «slips» although it **remains** engaged with torque equal to the limiter setting value; slipping stops as soon as the load returns to normal; in the case of very brief overloads the driven machine will continue normal operation (after decelerating or stopping) without requiring reset procedures.



The system, as the unit is mounted externally to the gear pair, will not alter if the direction of rotation changes and it does not affect the rigidity and meshing precision between worm and worm wheel (this is important to ensure the correct transmission of torque and the limitation of undue backlash between teeth through time). The system also permits **shaft mounting** with the limiter mounted **externally** (easily accessible) or in the **intermediate** position (better safety protection). It can be interposed, in the **combined units**, between initial worm gear reducer and final worm gear reducer, sizes **100 ... 250**.

On request slide detector. For more details see **specific literature**.

– **MLA unit, mechanical torque limiter on input shaft**, motor sizes **80 ... 200**.

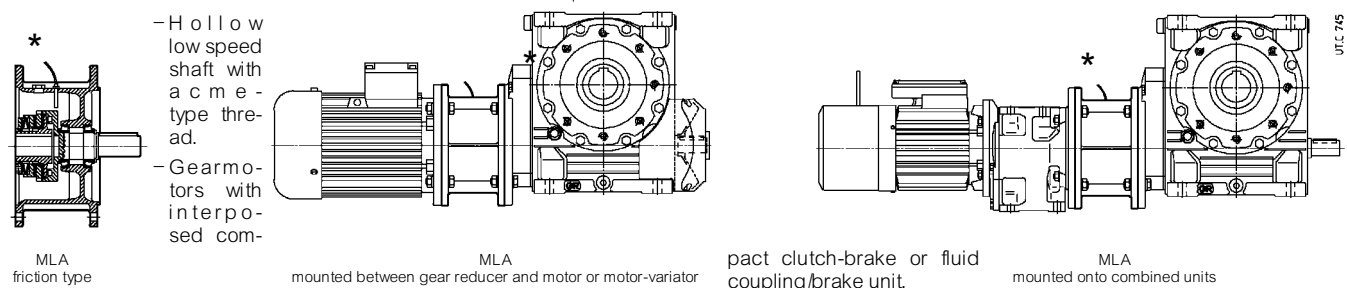
Mechanical torque limiter unit to be interposed between gear reducer and B5 mounting position motor standardized to IEC or (wide belt or planetary motor-variator) or, in **combined units**, between the initial gear reducer and the final worm gear reducer, sizes **50 ... 250**.

Axially ultra-compact design: excellent load bearing with life lubricated double row angular contact ball bearings (motor size  $\leq 112$ ) or «O» disposed taper roller bearings.

The unit protects the drive from accidental overloads by excluding inertia loads transmitted from up-line masses and if the gear reducer is reversible (the torque limiter being on the input shaft), inertia loads transmitted from down-line masses.

**LA unit is friction type** (friction surfaces without asbestos). When the transmitted torque tends to exceed the setting, the drive «slips» although **it remains** engaged and transmits torque equal to the limiter setting value; slipping stops as soon as the load returns to normal; in the case of very brief overloads the driven machine will continue normal operation (after decelerating or stopping) without requiring reset procedures.

On request slide detector. For more details see **specific literature**.

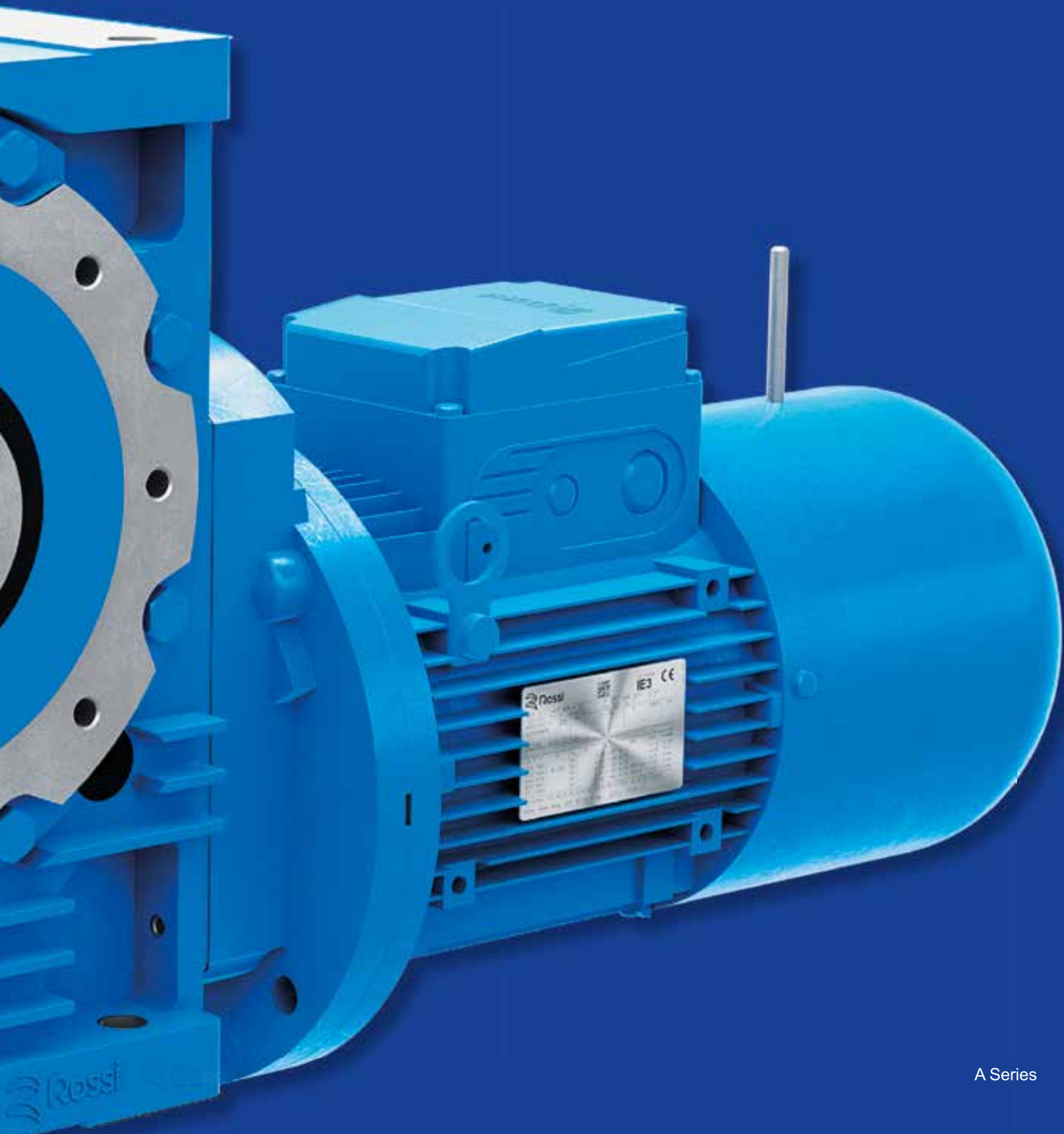


\* on request

- Semi-flexible and hydrodynamic couplings.
- Special paints
- Special seal rings; **double seal** (excluding sizes 32 ... 50).
- For high transmission ratios combined units can be also obtained with initial gearmotor **MR IV** with final gear reducer size  $\leq 81$  and with initial gearmotor **MR 2IV** for final gear reducer size  $\geq 100$ .

blank page

# Technical formulae







Main formulae concerning mechanical drives, according to the Technical System and International Unit System (SI).

Size	Con unità Sistema Tecnico With Technical System units	Con unità SI With SI units
starting or stopping <b>time</b> as a function of an acceleration or deceleration, of a starting or braking torque	$t = \frac{Gd^2 \cdot n}{375 \cdot M} [s]$	$t = \frac{J \cdot \omega}{M} [s]$
<b>velocity</b> in rotary motion	$v = \frac{\pi \cdot d \cdot n}{60} = \frac{d \cdot n}{19,1} [m/s]$	$v = \omega \cdot r [m/s]$
<b>speed n</b> and <b>angular velocity</b> $\omega$	$n = \frac{60 \cdot v}{\pi \cdot d} = \frac{19,1 \cdot v}{d} [min^{-1}]$	$\omega = \frac{v}{r} [rad/s]$
<b>acceleration</b> or deceleration as a function of starting or stopping time		$a = \frac{v}{t} [m/s^2]$
<b>angular acceleration</b> or deceleration as a function of a starting or stopping time, of a starting or braking torque	$\alpha = \frac{n}{9,55 \cdot t} [rad/s^2]$ $\alpha = \frac{39,2 \cdot M}{Gd^2} [rad/s^2]$	$\alpha = \frac{\omega}{t} [rad/s^2]$ $\alpha = \frac{M}{J} [rad/s^2]$
starting or stopping <b>distance</b> as a function of an acceleration or deceleration, of a final or initial velocity		$s = \frac{a \cdot t^2}{2} [m]$ $s = \frac{v \cdot t}{2} [m]$
starting or stopping <b>angle</b> as a function of an angular acceleration or deceleration, of a final or initial angular velocity	$\varphi = \frac{n \cdot t}{19,1} [rad]$	$\varphi = \frac{\omega \cdot t}{2} [rad]$
<b>mass</b>	$m = \frac{G}{g} [\frac{kgf \cdot s^2}{m}]$	$m$ è l'unità di massa [kg] $m$ is the unit of mass [kg]
<b>weight</b> (weight force)	$G$ è l'unità di peso (forza peso) [kgf] $G = m \cdot g [N]$ $G$ is the unit of weight (weight force) [kgf]	
<b>force</b> in vertical (lifting), horizontal, inclined motion of translation ( $\mu$ = coefficient of friction; $\varphi$ = angle of inclination)	$F = G [kgf]$ $F = \mu \cdot G [kgf]$ $F = G (\mu \cdot \cos \varphi + \sin \varphi) [kgf]$	$F = m \cdot g [N]$ $F = \mu \cdot m \cdot g [N]$ $F = m \cdot g (\mu \cdot \cos \varphi + \sin \varphi) [N]$
<b>dynamic moment Gd<sup>2</sup>, moment of inertia J</b> due to a motion of translation (numerically $J = \frac{Gd^2}{4}$ )	$Gd^2 = \frac{365 \cdot G \cdot v^2}{n^2} [kgf \cdot m^2]$	$J = \frac{m \cdot v^2}{\omega^2} [kg \cdot m^2]$
<b>torque</b> as a function of a force, of a dynamic moment or of a moment of inertia, of a power	$M = \frac{F \cdot d}{2} [kgf \cdot m]$ $M = \frac{Gd^2 \cdot n}{375 \cdot t} [kgf \cdot m]$ $M = \frac{716 \cdot P}{n} [kgf \cdot m]$	$M = F \cdot r [N \cdot m]$ $M = \frac{J \cdot \omega}{t} [N \cdot m]$ $M = \frac{P}{\omega} [N \cdot m]$
<b>work, energy</b> in motion of translation, in rotary motion	$W = \frac{G \cdot v^2}{19,6} [kgf \cdot m]$ $W = \frac{Gd^2 \cdot n^2}{7160} [kgf \cdot m]$	$W = \frac{m \cdot v^2}{2} [J]$ $W = \frac{J \cdot \omega^2}{2} [J]$
<b>power</b> in motion of translation, in rotary motion	$P = \frac{F \cdot v}{75} [CV]$ $P = \frac{M \cdot n}{716} [CV]$	$P = F \cdot v [W]$ $P = M \cdot \omega [W]$
<b>power</b> available at the shaft of a single-phase motor ( $\cos \varphi$ = power factor)	$P = \frac{U \cdot I \cdot \eta \cdot \cos \varphi}{736} [CV]$	$P = U \cdot I \cdot \eta \cdot \cos \varphi [W]$
<b>power</b> available at the shaft of a three-phase motor	$P = \frac{U \cdot I \cdot \eta \cdot \cos \varphi}{425} [CV]$	$P = 1,73 \cdot U \cdot I \cdot \eta \cdot \cos \varphi [W]$

Note. Acceleration or deceleration are understood constant; motion of translation and rotary motion are understood rectilinear and circular respectively.



**Rossi S.p.A.**  
Via Emilia Ovest 915/A  
41123 Modena - Italy

[info@rossi.com](mailto:info@rossi.com)  
[www.rossi.com](http://www.rossi.com)

2609.CAT.A.22.11-0-EN

© Rossi S.p.A. Rossi reserves the right to make any modification whenever to this publication contents. The information given in this document only contains general descriptions and/or performance features which may not always specifically reflect those described.

The Customer is responsible for the correct selection and application of product in view of its industrial and/or commercial needs, unless the use has been recommended by technical qualified personnel of Rossi, who were duly informed about Customer's application purposes. In this case all the necessary data required for the selection shall be communicated exactly and in writing by the Customer, stated in the order and confirmed by Rossi. The Customer is always responsible for the safety of product applications. Every care has been taken in the drawing up of the catalog to ensure the accuracy of the information contained in this publication, however Rossi can accept no responsibility for any errors, omissions or outdated data. Due to the constant evolution of the state of the art, Rossi reserves the right to make any modification whenever to this publication contents. The responsibility for the product selection is of the Customer, excluding different agreements duly legalized in writing and undersigned by the Parties.