

MR SERIES

Low-shear sanitary pumps



Watson-Marlow...Innovation in Full Flow

MasoSine MR Pumps: High-throughput sanitary pumps

MasoSine's MR pump satisfies demanding processing requirements cost-effectively, using the unique MasoSine pumping principle.

Design advantages

- Powerful suction even for viscous products
- Low pulsation for smooth, consistent flow
- Low-shear action does not damage fragile and shear-sensitive fluids
- Wearing parts easily replaced on site
- Holds 3-A Sanitary Standards authorization

Typical applications

- Cheese, curds and whey, cottage cheese, butter, yogurt
- Fruit concentrates, syrups, beer, wort, yeast
- Batter, frosting, fillings, slurries
- Soups, stews, deli salads
- Chocolate, caramel, fruit fillings

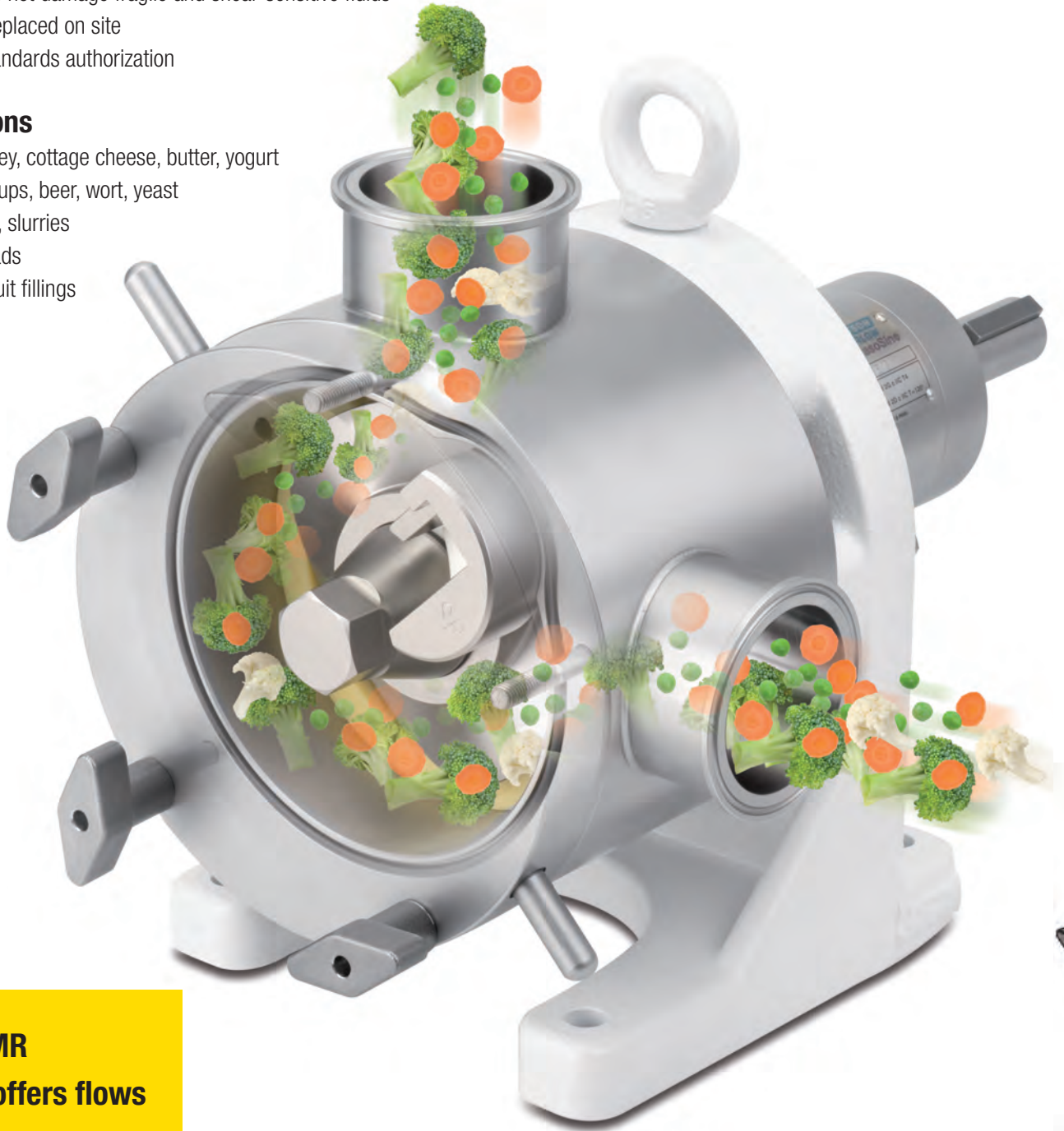

**The MasoSine MR
sanitary pump offers flows
to 400 gpm and
pressures to 150 psi.**

MasoSine MR Pumps: Options and accessories

High-temperature pumping

The MasoSine MR's heat-retaining (or heat-excluding) jacket allows the pump to reach the duty fluid temperature rapidly, and stay there. A heat-retaining front cover is available. This model is for high-throughput sanitary pumps up to 150 psi pressure.

Seal systems

MasoSine pumps have one shaft and therefore one seal, unlike regular two-shaft rotary lobe pumps that require two seals. The standard seal is a triple lipseal design, which is ideal for most food and beverage applications. Mechanical seal systems are available on request for applications where CIP is a requirement.

Ports

MasoSine pumps are supplied as standard with Tri-Clamp connections. I-Line, SMS and ANSI flanges are available on request. Customized ports can also be supplied.

Port orientation

MasoSine pump ports are orientated 90 degrees apart. They may be fitted in 45-degree incremental positions to fit your exact piping requirements. MasoSine MR pumps may be operated clockwise or counter-clockwise.

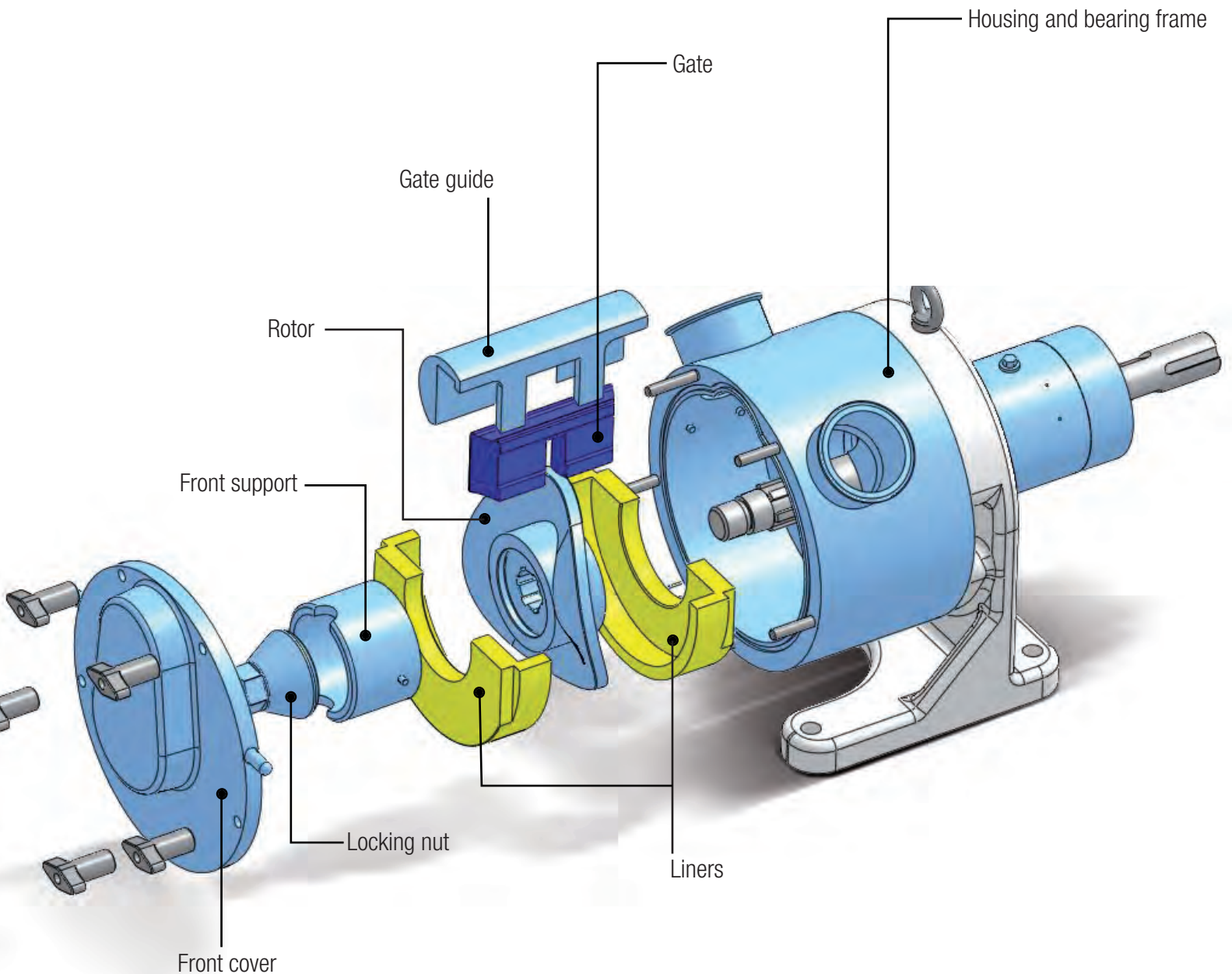

MasoSine MR Pumps: Performance tables and dimensions

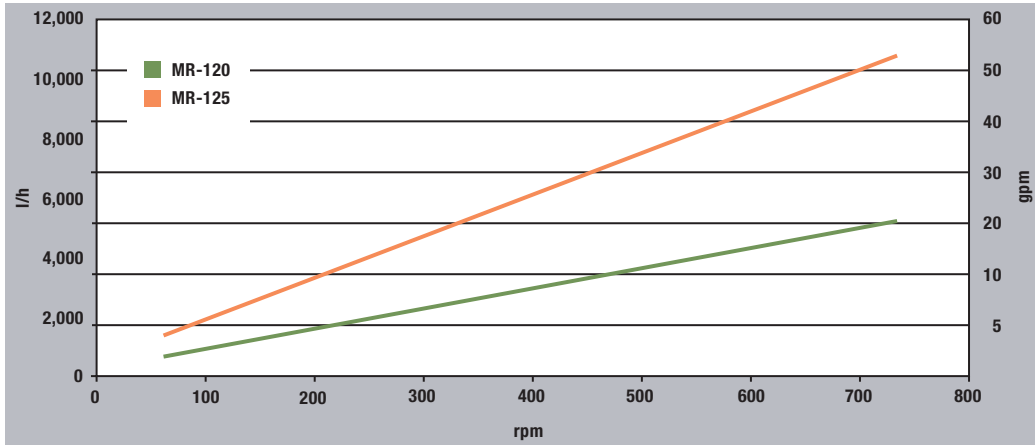

These curves are theoretical. Actual performance may be affected by pressure and viscosity.

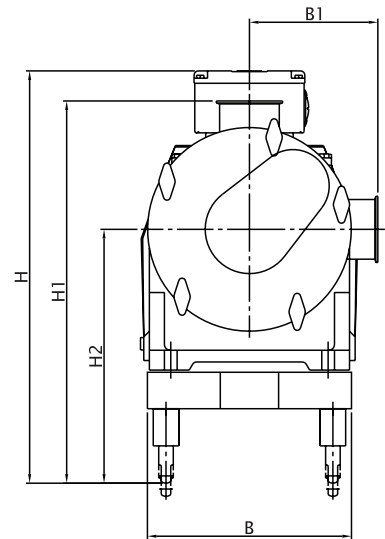
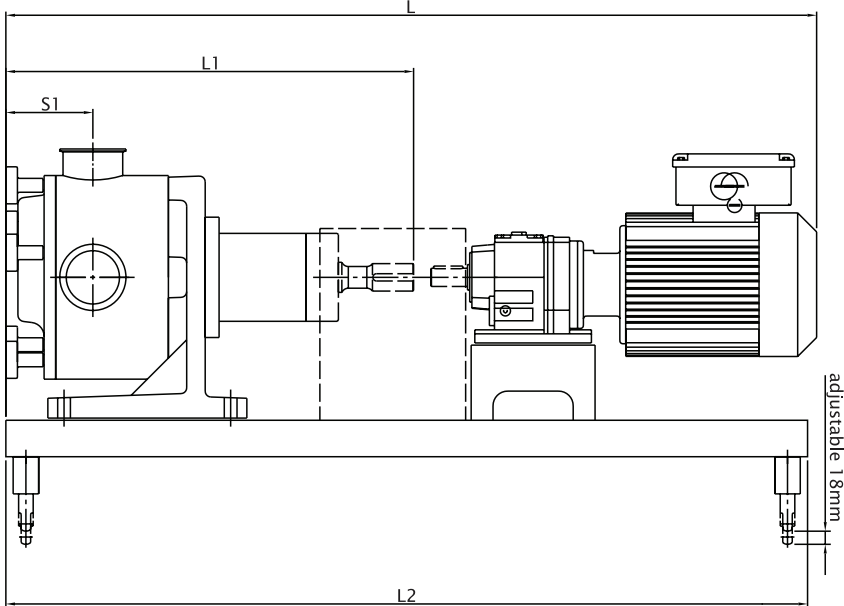
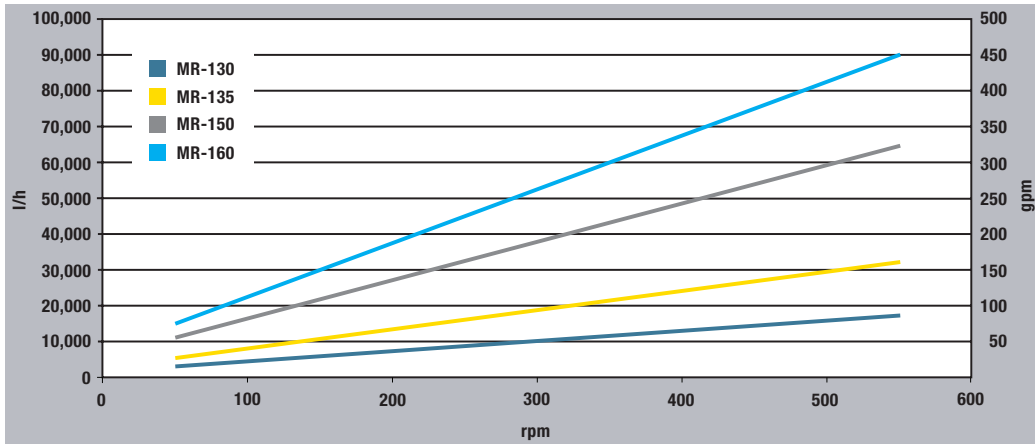

Model	L		L1	L2	S1	B	B1	H		H1	H2	
	min.	max.						min.	max.		min.	max.
MR-120	34.1	39.1	15.8	31.5	3.9	8.3	4.7	14.8	20.1	14.7	10.0	10.0
MR-125	34.1	42.7	16.6	31.5	4.2	8.3	5.2	15.1	20.9	15.9	9.7	11.5
MR-130	39.8	48.0	20.0	43.3	4.8	11.0	6.3	19.5	19.5	19.5	13.2	13.9
MR-135	43.7	53.7	22.0	43.3	4.7	11.0	6.9	20.6	22.2	20.6	13.7	14.4
MR-150	51.2	64.8	26.1	51.2	5.1	15.0	8.1	23.5	29.1	23.5	15.4	16.1
MR-160	51.3	82.7	27.0	55.1	9.2	15.8	10.6	26.0	33.8	26.6	15.4	19.2

Technical Data						
Model	flow per revolution	max. particle size	max. speed	inlet outlet*	shaft diameter	shaft height
MR-120	0.03 gal	0.5 in	800 rpm	2 in	25 mm (0.98 in)	114 mm (4.49 in)
MR-125	0.06 gal	0.75 in	800 rpm	2.5 in	25 mm (0.98 in)	146 mm (5.75 in)
MR-130	0.12 gal	1.0 in	600 rpm	3 in	38 mm (1.50 in)	181 mm (7.13 in)
MR-135	0.23 gal	1.25 in	600 rpm	3 in	38 mm (1.50 in)	193 mm (7.60 in)
MR-150	0.47 gal	2.0 in	600 rpm	4 in	50 mm (1.97 in)	235 mm (9.25 in)
MR-160	0.66 gal	2.25 in	600 rpm	6 in	65 mm (2.56 in)	235 mm (9.25 in)

*Note: Sizes listed are stocked items. Additional port options available upon request.

MasoSine MR Pumps: Applications



Food products

The MR pump is well-established in the food industry for transferring fluids containing soft solids. Typical applications include chicken breasts, ready meals, soups, sauces, frozen foods, and meat. Loading filling machines is a MasoSine specialty.



Beverages

The high suction capacity of the MR pump, over 80% vacuum, is valuable to the beverage industry. Orange juice concentrates with temperatures down to 14°F and other fruit juices are transferred without damaging the product.



Dairy products

MasoSine MR pumps are ideal for transferring sensitive cheese curd, yogurt, cream cheese, cottage cheese and cream. They are also perfect for adding fruit preparations and handling butter.



Cosmetics and pharmaceuticals

MR pumps are successful in the cosmetics industry for gentle transfer of shampoos, creams, pastes and lotions.



Fine chemicals

MR pumps stand out from the competition for handling shear-sensitive suspensions, solutions, soap and detergents, as well as very viscous media such as silicones.



Confectionery

In the confectionery industry, MR pumps transfer chocolate glazes and fillings, glucose, fats and many other products. A pump-housing heater is available for this application area.



Watson-Marlow Pumps Group

The Watson-Marlow Pumps Group has five world-class factories supported by direct sales operations in 20 countries and distributors in more than 50 countries. For contact details visit our website:

www.wmpg.com

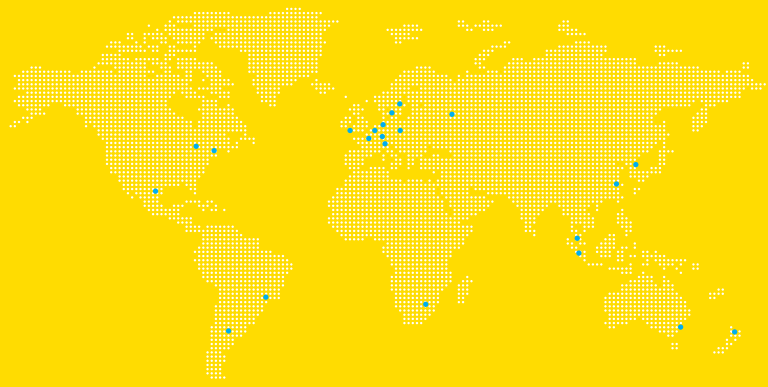

MasoSine Watson-Marlow Bredel Alitea Flexicon



Watson-Marlow online

Our engineers around the world can help you choose the perfect pump and tubing for your needs.

More information? Our brochures are on our website - www.wmpg.com



0810 - HB0311

Watson-Marlow...Innovation in Full Flow

Tel: 800-282-8823
support@wmpg.us

Watson-Marlow Pumps Group
37 Upton Technology Park
Wilmington, MA 01887

This information in this document is believed to be correct, but Watson-Marlow Pumps Group accepts no liability for any errors it contains, and reserves the right to alter specifications without notice. WARNING: These products are not designed for use in, and should not be used for, patient-connected applications. Watson-Marlow, Pumpsil, PureWeld XL, LoadSure, LaserTraceability, Bioprene and Marprene are registered trademarks of Watson-Marlow Limited. STA-PURE series PCS and STA-PURE series PFL and Style 400 are trademarks of WL Gore & Associates Inc.